

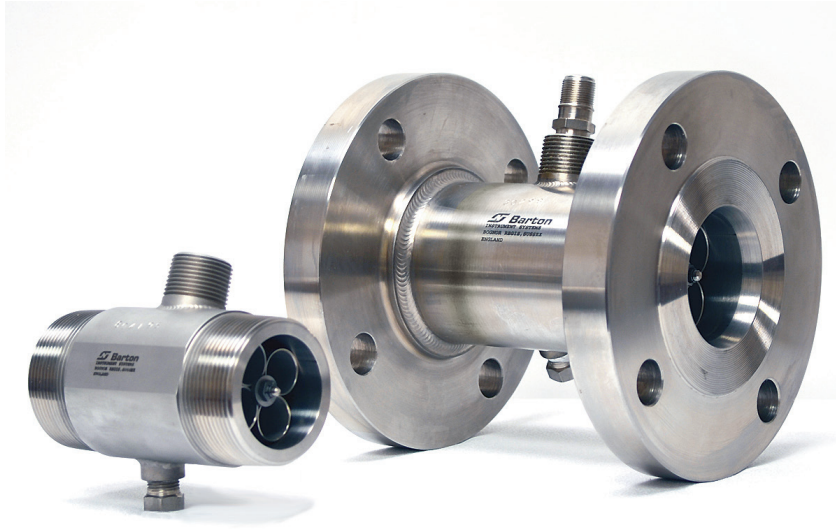

## 7400 Precision Gas Turbine Flow Meters



Model 7400 Precision Turbine Flow Meters are designed for gas service in a wide range of industrial, commercial, pipeline and aerospace applications. Because the output from the pickup coil is digital, Model 7400 meters are an excellent match for electronic output devices — no analog to digital conversion is required. The rotor response is in milliseconds, providing precise metering in applications with rapidly changing flow patterns.

### Features

- **High accuracy** – Custody transfer quality measurements with  $\pm 0.2\%$  of flow rate repeatability and a single K-factor linearity of better than  $\pm 1.0\%$  of reading over flow range.
- **Wide application** – Metering of gases from oxygen to ethylene for natural gas production, gas transmission, petrochemical, transport, aerospace and petroleum production/refining industries.
- **Responsive** – A major advantage over other primary flow devices. Rotor response in milliseconds provides precision even in rapidly changing environments.
- **High frequency digital output** – Easy interface with digital equipment.
- **Wide rangeability** – Depending on the flowing gas density, the meter often provides a turndown ratio greater than 10:1. Rangeability is extended with the addition of optional linearizing electronics.
- **Wide temperature and pressure ranges** – Flexible measurement options.
- **Symmetrical bi-directional design** – Ideal for reverse flow applications in which flow capacities are the same in either direction. Electronic options provide instantaneous flow direction sensing.
- **Compact and efficient** – Compared to other precision metering techniques, these turbine meters are able to handle a larger flow rate in a smaller meter and at a lower pressure drop. With the use of reduced diameter block valves and meter runs, substantial installation cost savings are achieved.
- **Low maintenance** – Sealed self-lubricating bearings for maintenance-free operation for typically up to 10 years.
- **Preventive maintenance** – Weldneck flange or unibody construction makes stress corrosion cracking easy to detect with a simple X-ray (unlike a welded slip-on flange).
- **Convenient packaging options** – Save time and money by ordering a meter system. The meter, companion electronics and meter run are factory assembled, configured and shipped to you, ready for installation.
- **Integral pressure tap** – Precisely positioned to accommodate pressure measurement at the turbine meter.
- **Mounting flexibility** – Meter can be installed in any orientation.



## Operation

As gas passes over the diffuser section, it is accelerated onto a multiblade turbine rotor. The rotor speed is proportional to the volumetric flow rate. As the rotor turns, a reluctance type pickup coil (mounted on the meter) senses the passage of each blade tip and in-turn generates a sine wave output with a frequency directly proportional to the flow rate. Additional coils can be added for redundancy or flow direction sensing.

The pickup coil can drive a variety of instruments, including, totalizers, pre-amplifiers or flow computers/ RTUs. Pre-amplifiers are used to transmit the coil signal over extended distances to remote instruments. All turbine instruments can be mounted directly to the turbine or remote-mounted and are available with intrinsically safe, explosion/flameproof or weatherproof approvals.

## Model Selection

The following chart provides a guideline for model selection based on actual flow rates.

### 7400 Model Selection (Actual Flowrate)

Model Number	Body Size		Minimum Repeatable				Rated Max.		Extended Range <sup>1</sup>		Nominal Meter Output (± 5.0)				
	in.	mm	0.25 lb/ft <sup>3</sup> (4kg/m <sup>3</sup> )		0.5 lb/ft <sup>3</sup> (8kg/m <sup>3</sup> )		2.0 lb/ft <sup>3</sup> (32.08kg/m <sup>3</sup> )		ACFM	ACMH	ACFM	ACMH	Pulses /ft <sup>3</sup>	Pulses /M <sup>3</sup>	Rated Max Freq. (Hz)
7486	3/4	20	1.4	2.37	1.0	1.69	0.5	0.85	6.7	11.3	7.4	12.5	21,600	762,800	2400
7450	1	25	2.7	4.58	1.9	3.22	1.0	1.69	15	25.5	17	28.0	10,700	377,900	2675
7475	1	25	3.2	5.42	2.3	3.90	1.25	2.12	22	37.4	24	40.7	7400	261,300	2715
7401	1	25	4.8	8.14	3.5	5.93	1.7	2.88	50	85	55	93.4	3350	118,300	2790
7446	1-1/2	40	12.5	21.19	8.5	14.41	4.2	7.12	125	212	138	234	1700	60,000	3540
7402	2	50	19	32.20	14.5	24.58	6.7	11.36	200	340	220	374	740	26,100	2465
7403	3	80	55	93.22	39	66.10	18.7	31.69	560	950	616	1045	190	6000	1770
7404	4	100	82	138.9	59	100.0	31	52.54	850	1445	935	1590	80	3000	1130
7406	6	150	215	364.4	158	267.8	73	123.7	2200	3740	2420	4110	22	1000	800
7408	8	200	340	576.3	243	411.9	117	198.3	3500	5950	3850	6540	9	400	525
7410	10	250	550	932.2	390	661.0	193	327.1	5800	9855	6380	10840	5	180	500
7412	12	300	850	1440.7	610	1033.9	300	508.5	9000	15290	9900	16820	3	105	450

<sup>1</sup>Operating continuously in the extended range will reduce the bearing life by approximately 25%

## Calculating Gas Turbine Meter Size

For calculating gas turbine meter size for conditions other than those given in selection table (actual flow rates) use the following method (per AGA-7):

$$(1) Q_f = \frac{P_b}{T_b} \times Q_h \times \frac{T_f}{P_f}$$

where:

- Q<sub>f</sub> = quantity rate of flow at line conditions
- P<sub>b</sub> = atmospheric pressure or pressure at base conditions
- T<sub>b</sub> = absolute temperature at base conditions
- Q<sub>h</sub> = quantity rate of flow at reference (base) conditions
- T<sub>f</sub> = absolute temperature at line conditions
- P<sub>f</sub> = absolute static pressure

$$(2) \gamma = \gamma_b \times \frac{P_f}{P_b} \times \frac{T_b}{T_f}$$

where:

- γ = density at flowing conditions
- γ<sub>b</sub> = density at base conditions

$$(3) Q_{f_{min}} = Q_{f_{ref}} \times \sqrt{\frac{\gamma_{ref}}{\gamma}}$$

where:

- Q<sub>f<sub>min</sub></sub> = rate of minimum linear flow at line conditions
- Q<sub>f<sub>ref</sub></sub> = minimum flowrate from flowrate table on page 2 from column selected for γ<sub>ref</sub>



## Specifications

<b>Compliances</b>	CSA certified for hazardous areas, Class I, Division I, Group B,C,D; Class II, E,F,G: Class III, Enclosure 4 waterproof to NEC (USA) and CEC (Canadian) standards															
	ATEX certified, EX d IIC															
	Compliant to ANSI 12.27.01-2003 single seal requirements															
	Measurement Canada Custody Transfer Certification G-0210															
	Canadian Registration Number 0F0123.2C															
	Available with CE mark for Pressure Equipment Directive (PED, 97/23/CE)															
Supplied with companion electronics for Class I/Zone 1 explosionproof/flameproof/ or intrinsic safety rating																
<b>Pressure Rating</b>	<b>Threaded Meters</b> – The table below contains pressure ratings for standard 316 stainless threaded meters. For higher pressure ratings, contact the factory.															
	<table border="1"> <thead> <tr> <th>Connection Size (in.)</th> <th>PSI</th> <th>Bar</th> </tr> </thead> <tbody> <tr> <td style="text-align: center;">&lt;1</td> <td style="text-align: center;">5000</td> <td style="text-align: center;">345</td> </tr> <tr> <td style="text-align: center;">1</td> <td style="text-align: center;">4400</td> <td style="text-align: center;">303</td> </tr> <tr> <td style="text-align: center;">1-1/2</td> <td style="text-align: center;">3200</td> <td style="text-align: center;">220</td> </tr> <tr> <td style="text-align: center;">2</td> <td style="text-align: center;">2650</td> <td style="text-align: center;">183</td> </tr> </tbody> </table>	Connection Size (in.)	PSI	Bar	<1	5000	345	1	4400	303	1-1/2	3200	220	2	2650	183
Connection Size (in.)	PSI	Bar														
<1	5000	345														
1	4400	303														
1-1/2	3200	220														
2	2650	183														
	<b>Flanged Meters</b> – Pressure ratings for flanged meters are based on standard ASME B16.5 (Material Group 1.1 for carbon steel; Material Group 2.2 for stainless steel)															
<b>Meter Sizes</b>	Threaded	3/4" - 2"														
	Flanged	3/4" - 12"														
<b>End Connections</b>	Threaded	BSP; NPT Others to special order														
	Flanged	ASME B16.5 (BS EN 1759) DIN (BS EN 1092)														

<b>Materials</b>	Rotor Blades	430 Stainless Steel
	Ball Bearings	440C Stainless Steel, with dry lubricant impregnated, Rulon® ball separators
	Body and Flanges	316 Stainless Steel
	Internals	316 Stainless Steel Others to special order
<b>Process Specifications</b>	Temp. Range*	Standard: -20° F to 302° F (-29° C to 150° C) Optional: -320° F to 302° F (-196° C to 150° C)
	Pressure Drop	1.8 psi (0.12 bar) at maximum flow rate (based on air with density of 1.0 lb/ft <sup>3</sup> [16 kg/m <sup>3</sup> ]). For specific flow rate values, see the Model Selection chart on page 2.
	Gas Density	0.08 to 4.5 lb/ft <sup>3</sup> (1.25 to 73 kg/m <sup>3</sup> ) Other densities available
*Note: This range is based on the temperature rating of meter bearings. Observe the temperature rating of companion electronics where applicable. Use remote mount electronics or electronics with temperature extensions to avoid temperature extremes.		
<b>Output</b>	Type	Sine Wave
	Voltage	Varies with meter size and flow rate. Typical values are: 20 - 500 mV rms on 3/4" (20 mm) 0.2 - 5V rms on 12" (300 mm)
	Frequency	Proportional to flow

## Performance and Calibration

The average K-factor for each turbine is determined at the factory by using water as the calibration media. Performed at six different flow rates, this multipoint calibration verifies linearity and repeatability over a limited range of the meter capacity. The average K-factors derived in water as compared to gas are within 1% deviation of each other. A water calibration is also an effective method to validate a meter in the field. Consult the factory for field water calibration procedures.

Gas calibrations are comparatively expensive but can be valuable in the following instances:

- When verifying the low-end capacity of the meter as would be required to implement electronic linearization.
- For testing of upper-end capacity of the meter. Full capacity testing can rarely be performed on water due to pressure drop issues.

Gas calibration should be performed on a gas density similar to the process fluid density.

Meter performance specified in this bulletin is based on historical gas calibration performed at independent world class calibration facilities using gas media. Not included in our accuracy statement is any systemic bias the calibration lab may have. Repeatability is limited by gas laboratory precision but in water is typically  $\pm 0.02\%$ .

Linearity indicates that no data point will exceed the average of all the data points within the linear meter capacity (normally 10 to 100% capacity) as per ISA standard RP31.1. Installation with straight pipe per American Gas Association report #7 is required to achieve the specified linearity.

Meters should be installed with upstream filtration to isolate the meter from contamination and damage from liquids or solids.

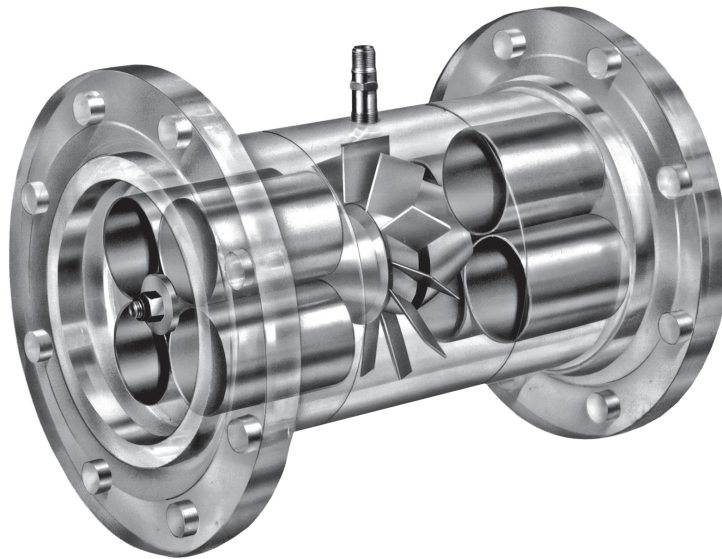



## Dimensions

### Flanged Meter

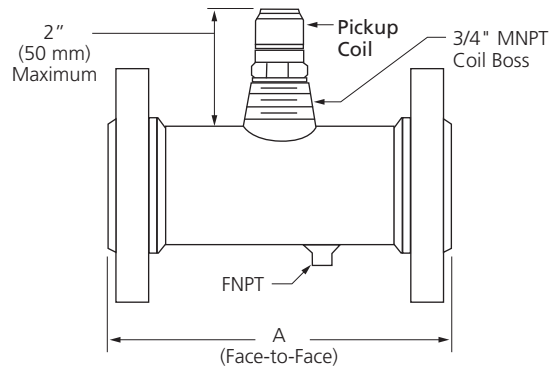

Rating	Face-to-Face Dimension (A)			
	BSEN 1759 (ASME)	Up to ASME 600	ASME 900 & 1500	ASME 2500
BSEN 1092 (DIN)	Up to PN 64	PN 100 & 160	PN 250 & 320	
Model	in.	mm	in.	mm
7486	5-1/2	140	7	178
7450	5-1/2	140	8	203
7475	5-1/2	140	8	203
7401	5-1/2	140	8	203
7446	6	152	9	229
7402	6-1/2	165	9	229
7403	10	254	10	254
7404	12	305	12	305
7406	14	356	14	356
7408	16	406	16	406
7410	20	508	20	508
7412	24	610	24	610

### Threaded Meter

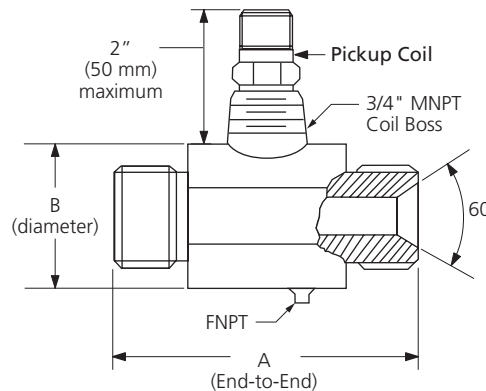

Model	Thread (BSP or NPT)	Dim. (A)		Dim. (B)	
		in.	mm	in.	mm
7486	3/4	3-3/4	83	1-1/4	32
7450	1	3-1/2	89	1-1/4	32
7475	1	3-1/2	89	1-1/2	40
7401	1	3-1/2	89	2-1/4	57
7446	1-1/2	4-3/8	111	2-3/4	70
7402	2	4-3/4	121	5-1/2	140

#### Integral Pressure Tap

Nominal Pipe Sizes (in.)	Tap Size (FNPT)
3/4 - 2-1/2	1/8"
3 - 8	1/4"
10 and 12	1/2"

### Performance

