



CONTROLS SUPPLY CHAIN  
VALVES ACTUATORS INSTRUMENTATIONS

# AMERICAN METER COMPANY CR4000



Installation Instructions

General Arrangement

Parts Lists

For: CR4000 Series Service Regulators

# CR4000 Service Regulators

## General Information:

The CR4000 is a standard service regulator with full capacity internal relief and comes standard with a 3/4" vent.

Available in 180° inline inlet/outlet sizes: 3/4" x 3/4", 3/4" x 1" and 1" x 1" NPT.

Also available in 90° inline inlet/outlet sizes: 3/4" x 3/4" and 3/4" x 1" NPT.

Maximum inlet pressure, normal service (P1): 125 PSIG.

Maximum outlet set pressure, normal service (P2):

Depending on spring selection up to 5 PSIG (138" W.C.).

### Caution:

#### Handling and Disposal:

"As a knowledgeable user of American Meter's products, we are sure that you are aware that parts in the Company's meters and regulators contain or are coated with heavy metals such as cadmium, zinc, lead and chromium. Obviously, therefore, repair or refurbishment of this equipment should take into account the presence of these materials and should comply with all state and federal requirements concerning worker protection, proper disposal and safety, including protection against exposure to dust and fumes."

## Seal Plugs

Seal Plug	Part Number
w/ Stamping	72283P005
w/o Stamping	72283F002
Red w/ Stamping	72283P007
Red w/o Stamping	72283F003

## Pressure Springs

Outlet Pressure Range	Color Code	Part No.
3.5" to 7" W.C.	Light Blue	70017P083
5" to 9" W.C.	Lavender	70017P084
6" to 15" W.C.	Light Gray	70017P088
18" to 2 PSIG	Light Green	70017P085
2 to 4 PSIG	Pink	70017P086
4 to 5 PSIG	Turquoise	70017P087

## Preparations:

### Caution:

Do not connect the inlet of the regulator to a normal pressure source higher than that recommended. Never connect the regulator outlet to the source of pressure. Observe the flow direction arrow on the valve body. If inlet pressure can exceed the maximum regulator outlet pressure rating, some form of overpressure protection in addition to internal relief may be required. To prevent damage to the regulator and possible personal injury, inlet and outlet pressures must not exceed the regulator pressure rating stated on page 4.

Install, operate, inspect and maintain the regulator as outlined in the following instructions and in accordance with your company's policies and applicable federal, state and local codes and laws. Failure to follow these instructions may result in damage to the regulator or personal injury.

2. Check installation location for suitability. It is possible that physical changes have been made to the building site since the regulator and location were originally selected.
3. Examine regulator for shipping damage.
4. Check regulator and piping for foreign matter which may have accumulated during shipment or handling.
5. Check seal plug information to determine if regulator is suitable for intended service.
6. Suitable stop valve(s) should be installed and should be conveniently located.
7. Filters are available from American Meter for applications where pipeline contaminants are suspected to be present.
8. Regulators may be used at temperatures between -20° F and +150° F (-30° C and +65° C).

## Installation:

### Warning:

#### Inside Installation:

Will require a vent line of sufficient diameter to carry gas vented by the regulator to a safe outside location away from any opening in the building. The CR4000 is provided with a 3/4" vent for the connection of a vent line. Do not thread a pipe into the vent more than 7 turns so as not to block the vent flapper.

#### Outside Installation:

Will require that care be taken to prevent vent opening from freezing closed or becoming blocked or permitting water to enter from any cause. Particular consideration should be given to sites where flooding, snow, or freezing rain may be experienced. The vent or vent line port should point vertically downward and overhead protection should be used where necessary.

(The numbers in parentheses refer to figure 1, page 3.)

1. Remove all shipping plugs.
2. Use good piping practice. Be sure piping and regulators are free of dirt, pipe dope and other debris. Apply pipe dope to male threads only.
3. Install regulator. Make certain it is piped correctly with inlet pipe connected to the inlet regulator connection and flow is in the direction as indicated by arrow located on regulator body (6). The vent should be positioned to prevent entry of water and debris. American Meter recommends that the vent face downward. Inside Installations - A regulator installed within a building should be located as near as practical to the point of service line entrance.
4. Turn gas on slowly. If an outlet stop valve is used, it should be open first. Do not overload the diaphragm with a sudden surge of inlet pressure.
5. Assure that there are no leaks and all connections are tight.
6. The CR4000 regulator is preset at the factory with the diaphragm in the horizontal position and should not require any adjustment if installed in that position. The outlet pressure may vary as much as 0.5" W.C. if the regulator is installed in the vertical position. Should you decide to adjust the set pressure, perform the following:
  - (a) Turn gas off and depressurize the system.
  - (b) Install outlet pressure gauge. Remove seal plug (12).
  - (c) Turn gas on slowly.

# CR4000 Service Regulators

- (d) Establish a low flow rate - 45 to 55 SCFH.
- (e) Turn pressure spring adjustment screw (7) clockwise to increase outlet pressure or counterclockwise to decrease outlet pressure.
- (f) Establish the set pressure within the range limits of the pressure spring used.
- (g) To test for the regulator's ability to fully shut off (lock-up), shut off all flow downstream of the regulator. At lock-up, the outlet pressure will be somewhat higher than the set pressure. However, if the pressure continues to rise after 3 seconds, the regulator must be repaired. Observe for 30 seconds.
- (h) When the set pressure has been properly adjusted, depressurize and remove gauge(s) and lines.
- (i) Replace seal plug (12).
- (j) Pressurize and check all connections for leaks.

## Inspection:

(Numbers in parentheses refer to figure 1.)

Inspection of the CR4000 has been simplified for practical reasons. If through this inspection process, parts are found to be damaged or worn, the regulator should be removed from service.

Inspection of the valve seat disc (1) and orifice valve (15) may be performed in the field. Follow the procedure described below. Care should be exercised to prevent foreign matter from entering the regulator.

### Procedure for Inspection of Valve Seat Disc and Orifice

1. Shut off gas supply and depressurize the regulator system.
2. Remove eight bolts (3) securing the diaphragm case (6) to the top assembly (16) and separate the diaphragm case from the top assembly.
3. Visually check the seating edge of the orifice (5). If it is nicked or damaged, the regulator should be removed from service and replaced with a new regulator.
4. Inspect the surface of the valve seat disc (1). If it is

- scored or uneven, the regulator should be removed from service and replaced with a new regulator.
- 5. Inspect unit for cleanliness and proper positioning of the parts.
- 6. If the regulator is not damaged install the top assembly (16) on the diaphragm case (6). Make sure the vent is pointed downward. Replace and tighten the diaphragm case screws (3).
- 7. Proceed to Steps 4, 5 and 6 of the installation instructions.

### Caution:

Regulators are pressure control mechanisms having numerous moving parts which can wear. In addition, regulator damage may occur from external sources. For these reasons, the regulator should be periodically inspected and checked for proper operation. The frequency of inspection will depend on the severity of the service conditions and the requirements of applicable local, state and federal codes and regulations.

## Replacing Pressure Spring:

(The numbers in parentheses refer to figure 1, page 3.)

### Caution:

Regulators that have a pressure spring removed or replaced must have their set pressure re-established. If the pressure spring is different from that shown on the seal plug or tag, mark spring range on the regulator seal plug or on its tag and cross out the old value.

1. Shut off gas supply and depressurize the regulator system.
2. Remove seal plug (12).
3. Unscrew pressure adjusting screw (7) with a 3/8" screwdriver and remove the pressure adjusting screw completely.
4. Remove the pressure spring (4). Install new pressure spring.
5. Replace the pressure adjusting screw and turn adjusting screw to about mid position.
6. Proceed to Steps 4, 5 and 6 in Installation Instructions.

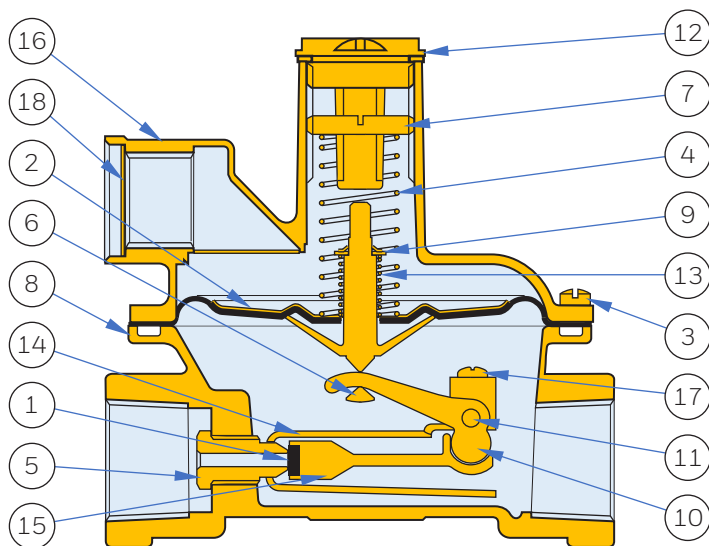

Figure 1 (CR4000 Regulator)

Item No.	Description	Item No.	Description
1	Disc, Valve Seat	10	Lever
2	Diaphragm Assembly	11	Pin, Lever
3	Screw, Diaphragm Case	12	Plug, Seal
4	Spring, Pressure	13	Spring, Relief Valve
5	Valve, Orifice	14	Guide, Valve Plunger
6	Diaphragm Case	15	Plunger, Valve
7	Screw, Pressure Adjustment	16	Assembly, Top
8	Stem, Relief Valve	17	Screw, Lever Pin
9	Retainer, RV Spring	18	Screen, Vent

# CR4000 Service Regulators

## Regulator Pressure Rating

125 PSIG = Maximum recommended inlet pressure for normal service. Maximum recommended pressure may vary with orifice size. 175 PSIG = Maximum inlet pressure for abnormal or emergency service, without causing damage to regulator case.

5 PSIG = Maximum outlet pressure for normal service.

10 PSIG = Maximum outlet pressure which can be contained by pressure carrying components (no flange leakage to atmosphere except for normal relief action). *If regulator is subjected to these conditions, it should be removed from service.*

50 PSIG = Maximum outlet pressure for abnormal service without damage to internal components. *If regulator is subjected to these conditions, it should be removed from service.*