

525 & 526 Series

Reducing and Back Pressure Regulators

Instruction Manual (Rev.E)



THESE INSTRUCTIONS PROVIDE THE CUSTOMER/OPERATOR WITH IMPORTANT PROJECT-SPECIFIC REFERENCE INFORMATION IN ADDITION TO THE CUSTOMER/OPERATOR'S NORMAL OPERATION AND MAINTENANCE PROCEDURES. SINCE OPERATION AND MAINTENANCE PHILOSOPHIES VARY, BAKER HUGHES COMPANY (AND ITS SUBSIDIARIES AND AFFILIATES) DOES NOT ATTEMPT TO DICTATE SPECIFIC PROCEDURES, BUT TO PROVIDE BASIC LIMITATIONS AND REQUIREMENTS CREATED BY THE TYPE OF EQUIPMENT PROVIDED.

THESE INSTRUCTIONS ASSUME THAT OPERATORS ALREADY HAVE A GENERAL UNDERSTANDING OF THE REQUIREMENTS FOR SAFE OPERATION OF MECHANICAL AND ELECTRICAL EQUIPMENT IN POTENTIALLY HAZARDOUS ENVIRONMENTS. THEREFORE, THESE INSTRUCTIONS SHOULD BE INTERPRETED AND APPLIED IN CONJUNCTION WITH THE SAFETY RULES AND REGULATIONS APPLICABLE AT THE SITE AND THE PARTICULAR REQUIREMENTS FOR OPERATION OF OTHER EQUIPMENT AT THE SITE.

THESE INSTRUCTIONS DO NOT PURPORT TO COVER ALL DETAILS OR VARIATIONS IN EQUIPMENT NOR TO PROVIDE FOR EVERY POSSIBLE CONTINGENCY TO BE MET IN CONNECTION WITH INSTALLATION, OPERATION OR MAINTENANCE. SHOULD FURTHER INFORMATION BE DESIRED OR SHOULD PARTICULAR PROBLEMS ARISE WHICH ARE NOT COVERED SUFFICIENTLY FOR THE CUSTOMER/OPERATOR'S PURPOSES THE MATTER SHOULD BE REFERRED TO BAKER HUGHES.

THE RIGHTS, OBLIGATIONS AND LIABILITIES OF BAKER HUGHES AND THE CUSTOMER/OPERATOR ARE STRICTLY LIMITED TO THOSE EXPRESSLY PROVIDED IN THE CONTRACT RELATING TO THE SUPPLY OF THE EQUIPMENT. NO ADDITIONAL REPRESENTATIONS OR WARRANTIES BY BAKER HUGHES REGARDING THE EQUIPMENT OR ITS USE ARE GIVEN OR IMPLIED BY THE ISSUE OF THESE INSTRUCTIONS.

THESE INSTRUCTIONS ARE FURNISHED TO THE CUSTOMER/OPERATOR SOLELY TO ASSIST IN THE INSTALLATION, TESTING, OPERATION, AND/OR MAINTENANCE OF THE EQUIPMENT DESCRIBED. THIS DOCUMENT SHALL NOT BE REPRODUCED IN WHOLE OR IN PART WITHOUT THE WRITTEN APPROVAL OF BAKER HUGHES.

Table of Contents

Safety Information	1
1. Introduction	2
2. General	2
3. Unpacking	2
4. Installation	3
5. Adjustment	3
6. Body Disassembly	3
6.1 525 (Reducing Service).....	3
6.2 526 (Back Pressure Service).....	3
7. Maintenance & Repair	4
7.1 Failure to shut off.....	4
7.2 Bushing Removal.....	4
7.3 Lapping Seats.....	4
7.3.1 525 (Reducing Service).....	4
7.3.2 526 (Back Pressure Service).....	5
7.4 Pinning.....	5
7.5 Packing Box.....	5
7.5.1 Carbon/PTFE Rings (Standard).....	6
8. Valve Body Reassembly	6
8.1 525 (Reducing Service).....	6
8.2 526 (Back Pressure Service).....	7
9. Actuators	7
9.1 Type 10900 Actuators.....	7
Assembly Torque Requirements	8
Parts References	9

Safety Information

Important - Please read before installation

These instructions contain **DANGER**, **WARNING**, and **CAUTION** labels, where necessary, to alert you to safety related or other important information. Read the instructions carefully before installing and maintaining your control valve. **DANGER** and **WARNING** hazards are related to personal injury. **CAUTION** hazards involve equipment or property damage. Operation of damaged **equipment can, under certain operational conditions, result in degraded process system performance that can lead to injury or death. Total compliance with all DANGER, WARNING, and CAUTION notices is required for safe operation.**



This is the safety alert symbol. It alerts you to potential personal injury hazards. Obey all safety messages that follow this symbol to avoid possible injury or death.



Indicates a potentially hazardous situation which, if not avoided, could result in death or serious injury.



Indicates a potentially hazardous situation which, if not avoided, could result in serious injury.



Indicates a potentially hazardous situation which, if not avoided, could result in minor or moderate injury.



When used without the safety alert symbol, indicates a potentially hazardous situation which, if not avoided, could result in property damage.

Note: Indicates important facts and conditions.

About this Manual

- The information in this manual is subject to change without prior notice.
-
- Please report any errors or questions about the information in this manual to your local supplier.
- These instructions are written specifically for the Regulator models 525 and 526, and do not apply for other equipment outside of this product line.

Useful Life

The current estimated useful life period for the **Masoneilan™** Regulator models 525 and 526 is 25+ years. To maximize the useful life of the product, it is essential to conduct annual inspections, routine maintenance and ensure proper installation to avoid any unintended stresses on the product. The specific operating conditions will also impact the useful life of the product. Consult the factory for guidance on specific applications if required prior to installation.

Warranty

is warranted to be free from defects in materials and workmanship for a period of one year from the date of shipment provided said items are used according to recommended usages. reserves the right to discontinue manufacture of any product or change product materials, design or specifications without notice.

Note: Prior to installation:

- The pressure regulator **MUST BE** installed, put into service and maintained by qualified and competent professionals who have undergone suitable training.
- All surrounding pipe lines must be thoroughly flushed to ensure all entrained debris has been removed from the system.
- Under certain operating conditions, the use of damaged equipment could cause a degradation of the performance of the system which may lead to personal injury or death.
- Changes to specifications, structure, and components used may not lead to the revision of this manual unless such changes affect the function and performance of the product

1. Introduction

The following instructions should be thoroughly reviewed and understood prior to installing, operating or performing maintenance on this equipment. Throughout the text, safety and/or caution notes will appear and must be strictly adhered to, otherwise, serious injury or equipment malfunction could result.

Serial Plate

The serial plate is usually fixed to the side of the actuator yoke. It indicates information about the regulator including size and type, pressure class rating, body/bonnet material, and serial number.

Spare Parts

Only Masoneilan replacement parts should be used when carrying out maintenance operations. Obtain replacement parts through local Masoneilan representatives or Masoneilan Parts Department.

When ordering spare parts, the MODEL AND SERIAL NUMBERS indicated on the manufacturer's serial plate MUST BE GIVEN. The serial plate is on the side of the actuator yoke.

Actuator and Accessories

Actuators and other valve accessories have their own instruction manuals that provide information and details on the assembly and installation. Refer to the appropriate instruction manual for each unique accessory.

2. General

These installation and maintenance instructions apply to all sizes and ratings of the Masoneilan 525/526 model regulators regardless of the type of trim used.

525/526 model double seat regulators are designed with built in versatility making them well-suited to handle a wide variety of process applications.

Standard construction offers a contoured plug with a threaded seat ring. The upper and lower plug guiding provides maximum support to ensure plug stability. A series of reduced area trim is available to provide wide flow range capabilities in all regulator sizes. Tight Shutoff Class II leakage is standard.

Recommended spare parts required for maintenance are listed in the Parts Reference table on page 9. The model number, size, rating and serial number of the valve are shown on the identification tag located on the actuator. Refer to the below chart for the 525/526 numbering system.

3. Unpacking

Care must be exercised when unpacking the regulator to prevent damage to the accessories and component parts. Should any problems arise, contact the local Masoneilan Representative or After Sales Department.

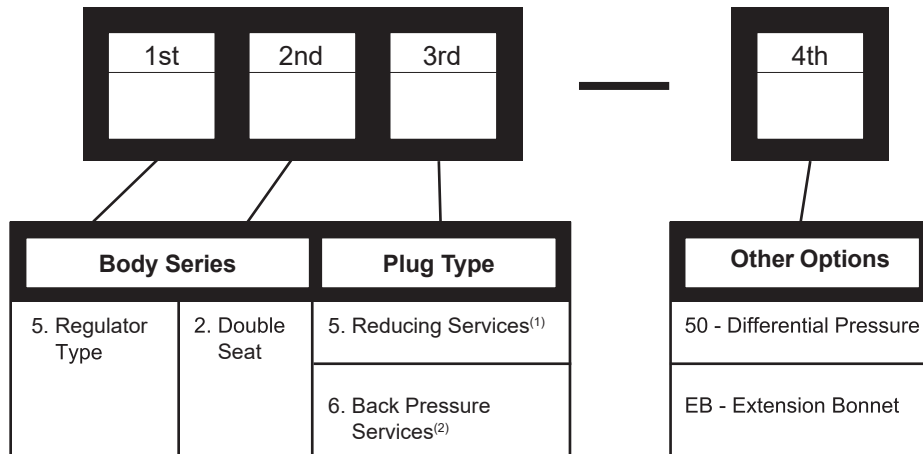

(1) Downstream Pressure Controlled (See Figure 1a)

(2) Upstream Pressure Controlled (See Figure 1b)

4. Installation

Before installing, blow out line thoroughly to remove all foreign matter which might foul the valve. Place the regulator in a horizontal run of pipe so that the controlled fluid will flow through the valve in the direction indicated by the arrow on the valve body or the words IN and OUT marked on the connections. On steam service, the valve should be installed with the diaphragm actuator down so that the diaphragm will be protected by a water seal. If installed otherwise, an adequate water seal must be incorporated.

Pipe the controlled pressure from a convenient point in the line 6-10 feet from the regulator (or in the discharge line

6-10 feet from the pump on pump pressure applications) to the ½" NPT connection in the diaphragm case. Install a gauge and a needle valve in the control line. The valve permits shutting off the control line and also serves as an adjustable choke to prevent cycling of the regulator, which may result from the pulsation of a pump in the system.

A three-valve bypass around the regulator permits removing the regulator from the line without shutting down the system.

5. Adjustment

When pressure setting is specified, the regulator is set accordingly at the factory; otherwise it is set at the minimum of the range shown on the serial plate.

Open stop valve on the outlet side of the regulator and partially open stop valve on the inlet side, allowing pressure in the system to build up slowly. Then open control line valve and check setting by means of the gauge. To increase pressure setting, turn adjusting screw clockwise to compress the spring. To decrease the setting, turn adjusting screw counterclockwise to relieve spring compression. Fully open stop valve on the inlet side of the regulator.

6. Body Disassembly

Access to the internal components of the body should be accomplished with the actuator removed. To remove the actuator from the body, refer to the Instruction Manual 31593 for 10900 Series Actuators.

CAUTION

Prior to performing maintenance on the valve, isolate the valve and vent the process pressure.

6.1 525 (Reducing Service)

After removing the actuator, disassemble the body using the following procedure:

- If there is a leak detector connection on the lateral NPT port of the bonnet, disconnect this piping as well.
- Remove body stud nuts (21).
- Remove bonnet (10), and plug stem (5) and plug (4) sub-assembly together as one unit.

Note: Spiral wound body gaskets (22) are standard in the 500 Series design and it is imperative that a new gasket be installed each time the valve is disassembled.

- Remove packing flange stud nuts (15), packing flange (13) and packing follower (12).
- Remove plug (4) and plug stem (5) sub-assembly from the bonnet (10).

CAUTION

Care must be taken to avoid damage to the plug and plug guide.

- Remove old packing (16) [and optional lantern ring (17) if a leak detection connection has been installed]. Refer to Figure 2.
- Remove blind head (9) [including lower bushing(23)]
Note: Spiral wound body gaskets (22) are standard in the 500 Series design and it is imperative that a new gasket be installed each time the valve is disassembled.
- Bonnet (10), plug (4), bushings (23) and seat rings (2 & 3) may now be inspected for wear and service damage. After determining the maintenance required, proceed to the appropriate Section of this instruction manual.

6.2 526 (Back Pressure Service)

After removing the actuator, disassemble the body using the following procedure:

- If there is a leak detection connection on the lateral NPT port of the bonnet, disconnect this piping as well.
- Remove body stud nuts (19).
- Remove packing flange stud nuts (15), packing flange (13) and packing follower (12)
- Remove bonnet (10)
- Remove blind head (9) [including lower bushing(23)]

Note: Spiral wound body gaskets (22) are standard in the 500 Series design and it is imperative that a new gasket be installed each time the valve is disassembled

- Plug stem (5) and plug (4) sub-assembly can now be removed together as one unit from the bottom of the valve.

CAUTION

Care must be taken to avoid damage to the plug and upper bushing (23).

- Remove old packing (16) [and optional lantern ring (17) if a leak detection connection has been installed]. Refer to Figure 2.
- All components may now be inspected for wear and service damage. After determining the maintenance required, proceed to the appropriate Section of this instruction manual.

7. Maintenance & Repair

The purpose of this section is to provide recommended maintenance and repair procedures. These procedures assume the availability of standard shop tools and equipment.

7.1 Failure to shut off

If there is excessive leakage through the valve when it is shut off, the cause may be foreign matter holding the plug off the seat. If so, disassemble and clean. If leakage is the result of normal wear, regrind the seating surfaces or, if necessary, replace the plug and/or seat rings.

7.2 Bushing Removal

The bushing (23) is press fit into the bonnet and blind head. This part does not normally require replacement. If necessary, it may be pulled or machined out. When machining the bushing out, care must be taken to maintain proper dimensions and tolerances in the bonnet or blind head. These will be furnished upon request.

7.3 Lapping Seats

Lapping Seats Lapping is the process of working the valve plug against the seat ring with an abrasive to produce a close fit. If valve leakage is excessive, lapping becomes necessary. The plug and seat ring seating surfaces should be free of large scratches or other defects, and the contact surfaces of the seats should be as narrow as possible. This may require dressing both parts in a lathe. A good grade of fine grinding compound is required for the lapping operation.

The compound should be mixed with a small quantity of lubricant such as graphite. This will slow the cutting rate and prevent tearing of the seating surfaces. The amount of lapping required depends on the materials, condition of seating surfaces, and accuracy of machining. If a short period of lapping does not visibly improve seating, there is usually no advantage in continuing as excessive lapping may result in rough seats. The only remedy is replacement or re-machining of one or both parts. When lapping new plugs and seat rings, begin with a medium fine (240 grit) and finish with a finer grade (600 grit).

Note: *Lapping should produce a line contact area, not the entire surface.*

CAUTION

Before lapping, the plug and stem sub-assembly must be concentric. (See pinning operation, section 7.4).

7.3.1 525 (Reducing Service)

1. Clean body gasket surface areas.
2. When seats have been removed, insure that the sealing surfaces in the body bridge and the threads are thoroughly cleaned.

Note: *A sealant compatible with the process should be applied sparingly to the seat ring threads and sealing shoulder.*

3. Install and tighten seat rings using fabricated wrench used for removal.

CAUTION

Do not over-tighten. Do not strike seat ring lugs directly. This could distort the seat ring resulting in seat leakage.

4. Apply lapping compound on the plugs at several spots equally spaced around the seating area.
5. Insert the stem and plug sub-assembly carefully into the body until it is seated.
6. Place bonnet (8) on the body and fasten the bonnet to the body using four body stud nuts (10) spaced equally apart. Apply slight pressure and tighten evenly.

CAUTION

Do not tighten nuts to final torque specifications at this time. The bonnet is used temporarily for guiding purposes only.

7. Insert two or three pieces of packing (16) into the packing box to assist in guiding the stem and plug during lapping.
8. Screw a drilled and tapped rod with a T-handle onto the plug stem and secure with a locknut (see Figure 3).

Note: *As an alternative, drill a hole through a flat steel plate and fasten to the plug stem using two locknuts.*

9. Apply slight pressure on the stem, and rotate the stem in short oscillating strokes (around 8 to 10 times). Repeat this step as necessary.

Note: *The plug should be lifted and turned 90° each time before repeating Step (9). This intermittent lifting is required to keep the plug and seat rings concentric during lapping.*

CAUTION

Avoid over-lapping as this can cause damage to the seating surface rather than improve leakage performance.

10. After completion of the lapping operation, remove bonnet and plug. The seating area of the seat ring and the plug must be cleaned of all lapping compound in preparation for reassembly. **Do not remove seat ring.**

7.3.2 526 (Back Pressure Service)

1. Clean body gasket surface areas.
2. When seats have been removed, insure that the sealing surfaces in the body bridge and the threads are thoroughly cleaned.

Note: *A sealant compatible with the process should be applied sparingly to the seat ring threads and sealing shoulder.*

3. Install and tighten seat rings using fabricated wrench used for removal.

CAUTION

Do not over-tighten. Do not strike seat ring lugs directly. This could distort the seat ring resulting in seat leakage.

4. Apply lapping compound on the plugs at several spots equally spaced around the seating area.
5. Insert the stem and plug sub-assembly carefully into the body until it is seated.
6. Place bonnet (8) on the body and fasten the bonnet to the body using four body stud nuts (10) spaced equally apart. Apply slight pressure and tighten evenly.

CAUTION

Do not tighten nuts to final torque specifications at this time. The bonnet is used temporarily for guiding purposes only.

7. Insert two or three pieces of packing (16) into the packing box to assist in guiding the stem and plug during lapping.
8. Screw a drilled and tapped rod with a T-handle onto the plug stem and secure with a locknut (see Figure 3).

Note: As an alternative, drill a hole through a flat steel plate and fasten to the plug stem using two locknuts.

9. Apply slight upward pressure on the stem to establish seating contact, and rotate the stem in short oscillating strokes (around 8 to 10 times). Repeat this step as necessary.

Note: The plug should be lifted and turned 90° each time before repeating Step (9). This intermittent lifting is required to keep the plug and seat rings concentric during lapping.

CAUTION

10. Avoid over-lapping as this can cause damage to the seating surface rather than improve leakage performance.
11. After completion of the lapping operation, remove bonnet and plug. The seating area of the seat ring and the plug must be cleaned of all lapping compound in preparation for reassembly. **Do not remove seat ring.**

7.4 Pinning

Valve plug and stem assemblies are normally furnished as a complete assembly in which case the installation involves no further assembly steps. It is only necessary to lap the plug and seat ring and assemble the valve. If it is necessary to replace the plug it is recommended that a new stem be used. If the old stem must be used, it is necessary to determine if the stem will be long enough since the stem will require cutting. If the stem does not engage the actuator stem by a minimum of one stem diameter, the old stem should not be used. If it does engage a minimum of one stem diameter, proceed as follows.

Note: While pinning is being performed, care must be taken

not to damage the seating surface and plug guides.

- A. Using a drift punch, drive out the old pin (8).

Note: If it is necessary to drill out the pin, a drill somewhat smaller than the pin should be used and the remainder of the pin driven out.

- B. Unscrew the plug from the stem (counter clock-wise).
- C. Measure threaded portion of the stem.
- D. Cut off the stem directly above the existing pin hole.
- E. Rethread the stem to the original amount.

Note: The area of the plug stem marked X in Figure 4 serves as a guide and must be checked to ensure a close fit in the valve plug.

- F. Screw the stem solidly into the plug.

Note: This can be checked by measuring the depth of the pilot recess in the plug (X in Figure 4), and making a reference mark on the stem the same distance from the thread. When properly assembled, the reference mark should be flush with the end of the guide section.

- G. Place the plug guide on a V block and using a suitable size drill, drill the stem using the hole in the plug as a guide.
- H. Remove any burrs from the plug guide by making a slight counter bore.
- I. Select the correct size pin, apply a small amount of grease on it and press into the hole.

Note: The pin must be recessed approximately 1/16" below the plug guide surface.

- J. After the plug has been pinned it should be placed in a lathe to ensure it is running true. If it is not, strike the plug with a soft faced mallet to straighten.

Note: The plug should be placed in a collet with the plug guide against it and the plug should be struck.

7.5 Packing Box

Packing box maintenance is one of the principle action items of routine servicing. Tightness of the packing is maintained by packing compression. Compression is achieved by evenly tightening the packing flange nuts (15) against the packing flange (13). Care must be taken not to over tighten as this could prevent smooth operation of the valve. If all compression is used up and the valve leaks, then new packing is required.

CAUTION

Valve must be isolated and the pressure vented before performing packing box maintenance.

Proceed as follows:

7.5.1 Carbon/PTFE Rings (Standard)

Note: The Carbon/PTFE packing rings have a skive cut allowing packing replacement without disconnecting the plug stem from the actuator connector or actuator stem.

- A. Loosen and remove packing flange nuts (15).
- B. Lift the packing flange (13) and packing follower (12) up the valve stem.

Note: These parts may be secured using tape or wire to keep them out of the way before proceeding.

- C. By means of a hooked instrument, remove packing (16) insuring not to damage the sealing surfaces of the packing box or plug stem.

Note: On valves equipped with an optional lubricator connection, the lantern ring (17) must also be removed to gain access to lower packing rings.

- D. Replace packing rings (16).

Note: Assemble and compress rings one at a time into packing box. The skive cut of each packing ring must be placed about 120 degrees apart.

Note: On valves equipped with an optional lubricator connection, refer to Figure 2 for correct amount of rings to place under the lantern ring (17).

- E. Replace packing follower (12) and packing flange (13).
F. Replace and tighten packing stud nuts (15).

CAUTION

Do not over tighten.

- G. Place valve back in service and only tighten packing as necessary to stop external leakage.

Note: In an emergency, string packing may be used as a temporary repair only. It must be replaced with the correct packing as soon as possible.

8. Valve Body Reassembly

After completion of the required maintenance, the valve should be reassembled using the following procedures:

Note: If any of the following steps were completed during maintenance, then proceed to the next step.

8.1 525 (Reducing Service)

- A. Clean all gasket mating surfaces.
B. Apply a small amount of sealant to the seat ring threads and sealing shoulders. Install seat rings into valve body.
Note: A sealant compatible with the process should be applied sparingly.
C. Install and tighten seat rings using wrench used for removal.

CAUTION

Do not over-tighten. Do not strike seat ring lugs directly. This could distort the seat ring resulting in unwarranted seat leakage.

- D. Install body-blind head gasket
E. Install blind head

CAUTION

Tighten nuts (10) until metal to metal contact is obtained with proper bolt torque. Refer to Table 1 for proper bolt torque and tightening sequence specifications.

- F. Carefully install plug and stem assembly, carefully inserting lower guide into lower bushing.

Note: Valve should be lapped before final assembly. See Section 7.3.

- G. Install body gasket (22).

Note: Spiral wound body gaskets (22) are standard in the 500 Series design. It is imperative that a new gasket be installed each time the valve is disassembled.

- H. Assemble bonnet (10) and body stud nuts (21). Bonnet must be positioned so the packing flange studs are at 90° to the flow center line.

CAUTION

Tighten nuts (21) until metal to metal contact is obtained with proper bolt torque. Refer to Table 1 for proper bolt torque and tightening sequence specifications.

- I. Insert packing (16) (and lantern ring (17) on valves equipped with an optional lubricator connection). Refer to Section 7.5 for proper packing assembly procedure for standard or optional designs.
J. Install packing follower (12) and packing flange (13).
K. Install packing flange stud nuts (15).

CAUTION

Do not over tighten (See Section "7.5. Packing Box").

- L. If a leak detection connection was installed, connect it on the lateral NPT port in the bonnet. If not, insure that the 1/4" NPT plug remained in place (Figure 2).
M. For actuator assembly and plug stem adjustment, proceed as per the Instruction Manual 31593 for 10900 Series Actuators.

8.2 526 (Back Pressure Service)

- A. Clean all gasket mating surfaces.
B. Apply a small amount of sealant to the seat ring threads and sealing shoulders. Install seat rings into valve body.
Note: A sealant compatible with the process should be applied sparingly.
C. Install and tighten seat rings using wrench used for removal.

CAUTION

Do not over-tighten. Do not strike seat ring lugs directly. This could distort the seat ring resulting in unwarranted seat leakage.

Note: Valve should be lapped before final assembly. See Section 7.3.

- D. Carefully install plug and stem assembly into valve body.
E. Install body-blind head gasket
F. Install blind head, carefully inserting lower guide into lower bushing.

G. Install body gasket (22).

Note: Spiral wound body gaskets (22) are standard in the 500 Series design. It is imperative that a new gasket be installed each time the valve is disassembled.

H. Assemble bonnet (10) and body stud nuts (21). Bonnet must be positioned so the packing flange studs are at 90° to the flow center line.

CAUTION

Tighten nuts (21) until metal to metal contact is obtained with proper bolt torque. Refer to Table 1 for proper bolt torque and tightening sequence specifications.

I. Insert packing (16) (and lantern ring (17) on valves equipped with an optional lubricator connection). Refer to Section 7.5 for proper packing assembly procedure for standard or optional designs.

J. Install packing follower (12) and packing flange (13).

K. Install packing flange stud nuts (15).

CAUTION

Do not over tighten (See Section "7.5. Packing Box").

L. If a leak detection connection was installed, connect it on the lateral NPT port in the bonnet. If not, insure that the 1/4" NPT plug remained in place (Figure 2).

M. For actuator assembly and plug stem adjustment, proceed as per the Instruction Manual 31593 for 10900 Series Actuators.

9. Actuators

9.1 Type 10900 Actuators

Refer to Instruction Manual 31593 for removal, maintenance, assembly and adjustment.

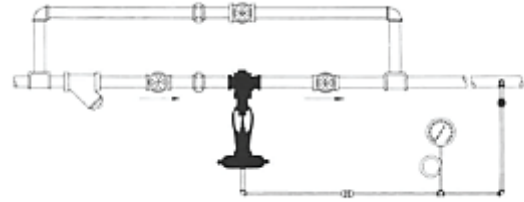

Figure 1a: Typical Reducing Application

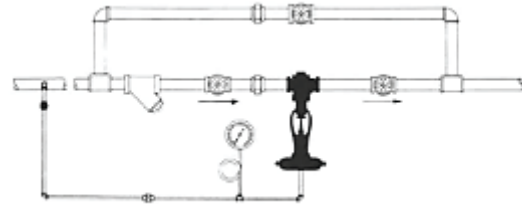

Figure 1b: Typical Back Pressure Application

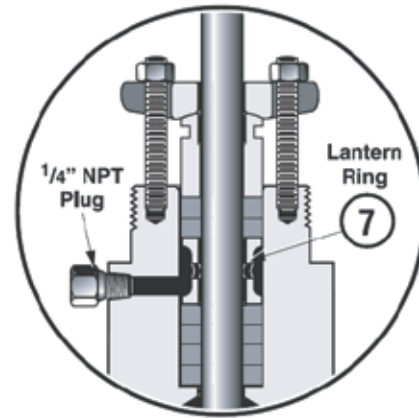

Figure 2: Lubricator Connection (Optional)

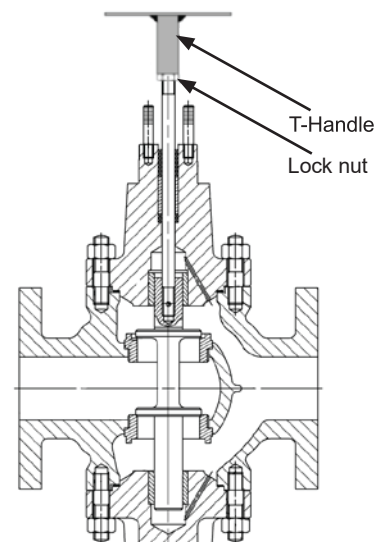

Figure 3: Seat Lapping Device

Table 1: Assembly Torque Requirements

Valve Size		ANSI Class	Bolting Requirements		Torque Requirements					
					Minimum		Maximum		Pre-Load	
inch	mm		Qty	Size (inch)	Lbs.Ft	N.m	Lbs.Ft	N.m	Lbs.Ft	N.m
3/4	20	150 & 300	6	1/2"-13NC-2A	25	34	55	75	5	7
		600	6	1/2"-13NC-2A	25	34	55	75	5	7
1	25	150 & 300	6	1/2"-13NC-2A	25	34	55	75	5	7
		600	6	1/2"-13NC-2A	25	34	55	75	5	7
1 1/2	40	150 & 300	6	1/2"-13NC-2A	25	34	55	75	5	7
		600	6	1/2"-13NC-2A	25	34	55	75	5	7
2	50	150 & 300	8	1/2"-13NC-2A	25	34	55	75	5	7
		600	8	1/2"-13NC-2A	25	34	55	75	5	7
3	80	150 & 300	8	5/8"-11NC-2A	45	61	89	120	10	14
		600	8	5/8"-11NC-2A	45	61	89	120	10	14
4	100	150 & 300	8	3/4"-10NC-2A	80	108	170	230	20	27
		600	8	3/4"-10NC-2A	80	108	170	230	20	27

Notes:

1. Do not exceed Maximum Torque values listed.
2. Tighten in increments until required torque levels are reached.
3. Reject assembly if metal-to-metal contact is not achieved after reaching Maximum Torque.
4. Torque requirements shown are for standard B7 studs and 2H nuts.

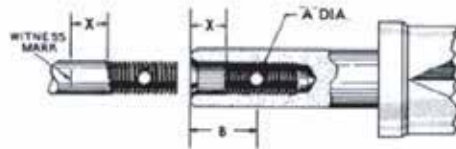

Stem. Dia.	Hole Dia. "A"		"B"		"X"	
	in	mm	in	mm	in	mm
1/2	0,188	4,78	1,250	31,75	0,50	12,7
5/8	0,219	5,56	1,562	39,67	0,62	15,7
3/4	0,250	6,35	1,875	47,63	0,75	19,1
1	0,312	7,92	2,500	63,50	1,00	25,4

Figure 4: Bolt Pinning Dimensions

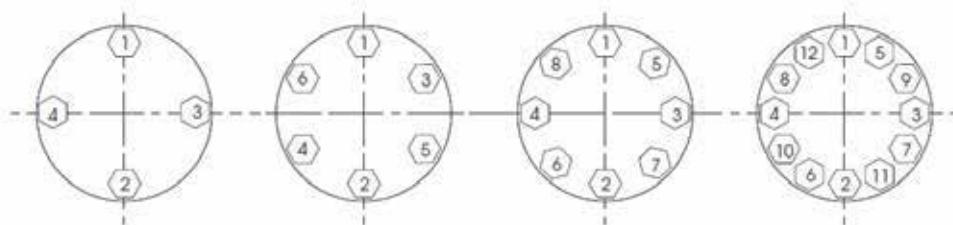
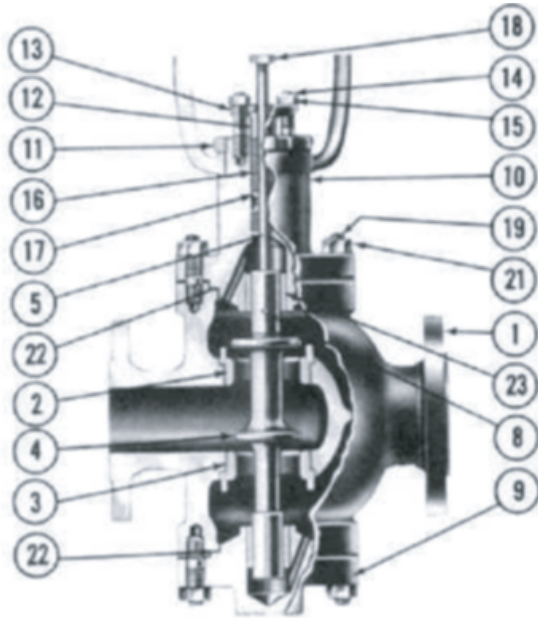
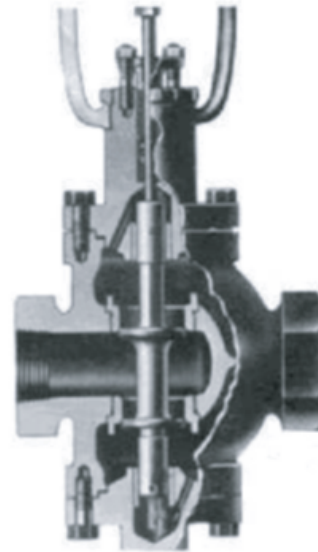

Figure 5: Bolt Tightening Sequence



525 Reducing Service



526 Back Pressure

Parts References

Ref.	Part Name	Ref.	Part Name	Ref.	Part Name
1	Body	10	Bonnet	17	Lantern Gland (Optional)
● 2	Upper Seat Ring	11	Drive Nut	18	Plug Stem Locknut
● 3	Lower Seat Ring	12	Packing Follower	19	Body Stud
● 4	Plug	13	Packing Flange	21	Body Nut
● 5	Plug Stem	14	Packing Stud	● 22	Gasket
● 8	Plug Pin	15	Packing Nut	23	Guide Bushing
9	Blind Head	● 16	Packing		

● Recommended Spare Part



CONTROLS SUPPLY CHAIN

VALVES ACTUATORS INSTRUMENTATIONS