

BR200/BR400

High Capacity Volume Booster Relays

Instruction Manual (Rev. C)

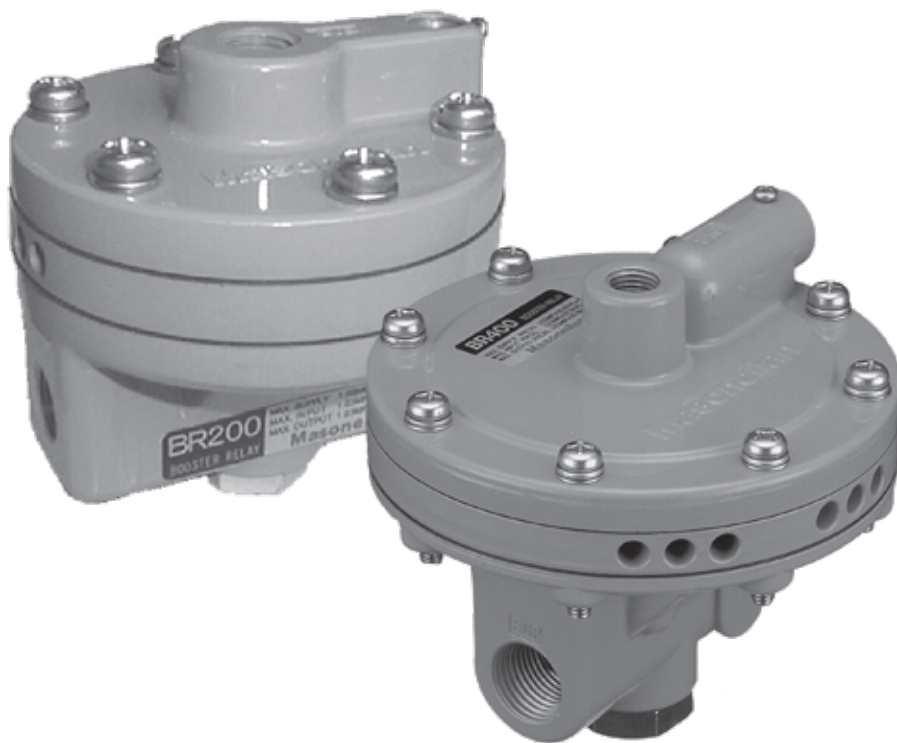

Product Description

Masoneilan™ BR400 and BR200 are high capacity volume boosters for applications that require fast stroking speeds using pneumatic actuators. Stable operation over a wide range of actuator sizes can be obtained by adjusting the bypass valve on the booster to modify the dynamic response. The models BR200 and BR400 are equally suitable for use on diaphragm or piston actuators.

Features and Benefits

- Flow characteristics suitable for control valves
- Short stroking times with consistently stable operation for use on high-volume actuators or on very demanding stroking time control valve applications
- Built-in bypass valve with locking screw to adjust sensitivity and dynamic response
- Filter on the supply port to protect instrument from particles in air supply
- Corrosion resistant finish and stainless assembly hardware to permit use in corrosive atmosphere

Principle of Operation

The input signal pressure is applied to the upper diaphragm to produce a force that is opposed in a 1:1 ratio by the output pressure acting on the lower diaphragm through the seal plate orifice. An increase in the input signal pressure will depress the top diaphragm and open the pilot valve, allowing supply pressure to the output until the output pressure action on the lower diaphragm re-balances the forces. Conversely, a decrease in the input signal pressure allows the exhaust valve to open until the output pressure falls to the same value as the input signal pressure.

A bypass valve allows a controlled flow of input signal direct to the output to obtain stable control for small or slow changing input signals.

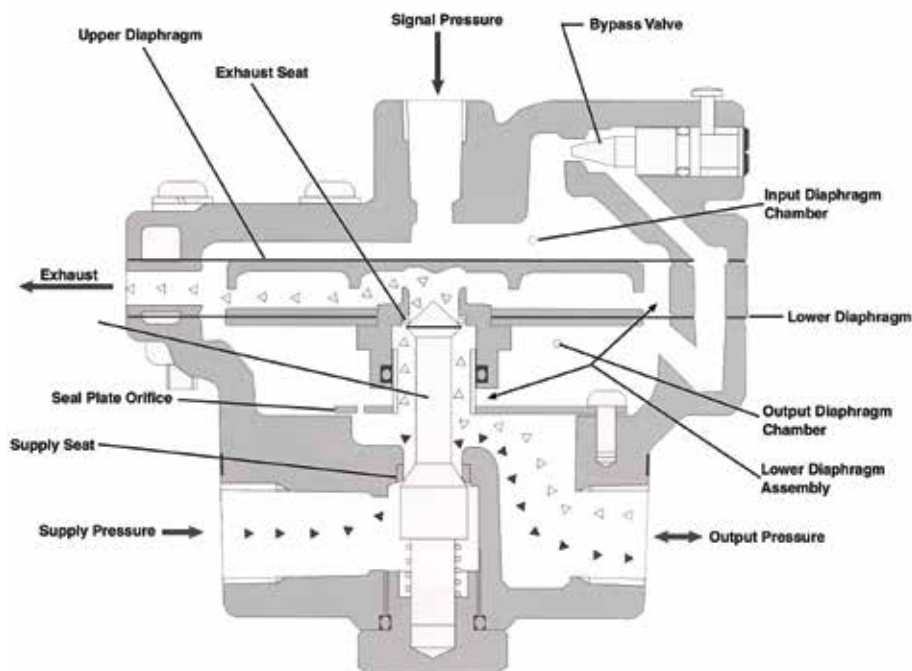

Figure 1 - Cut-away View of BR400 Booster Relay

Pneumatic Supply

The BR400 and BR200 Booster Relays require a source of clean, dry, oil-free, instrument grade air to ANSI/ASA-57.3 1975 (R1981) or ISA-S7.3-1075 (R1981).

Maximum Supply Pressure	150 psi (10.3 bar)
Dew Point	At least 18°F (10°C) below minimum anticipated ambient temperature.
Particulate Matter	Filtered to below 5 microns.
Oil Content:	Less than 1 ppm w/w or v/v.
Contaminants	Free of all corrosive contaminants and hazardous gasses, flammable or toxic.

Pneumatic Connections

The pneumatic connection locations are shown on Figure 1 and are also stamped on relay body. The supply and output connections are 1/4" NPT and the signal connection is 1/4" NPT. The supply and output tubing should be a minimum of 1/2". Blow out all piping prior to connecting to booster. Use of a soft setting anaerobic hydraulic seal, such as Loctite Hydraulic Seal 542 is recommended on the male threads of all connections.



Do not use an excessive amount of hydraulic sealant as it will not set and may migrate into the pneumatic passages.



Do not use pipe thread sealant tape on pneumatic fittings, as it tends to shred small particles which can cause instrument malfunction.

Installation

The booster relay should be close coupled to the actuator. Use of a short 1/2" pipe nipple between the relay output and the actuator provides both the pneumatic connection and mounting means. The preferred orientation is with the exhaust openings pointing down; however horizontal mounting is acceptable.

Specifications

Features	Specifications
Maximum Cv (supply)	1.2 (BR200) and 2.6 (BR400)
Maximum Cv (exhaust)	1.2 (BR200) and 2.4 (BR400)
Maximum Signal Pressure	150 psi (10.3 bar)
Operating Temperature Limits	-30°C to +83°C (-22°F to +181°F) Low Temperature: -55°C to +60°C (-67°F to +140°F) High Temperature: 0°C to +100°C (32°F to +212°F)
Input / Output Ratio	1:1
Supply and Output Connections	1/4" NPT or Rc (BR200) and 1/2" NPT or Rc (BR400)
Signal Connection	1/4" NPT or Rc
Approximate Weight	0.7 kg (1.5 lbs) for BR200 and 1.4 kg (3 lbs) for BR400

Table 1 - Specifications

Flow Characteristics

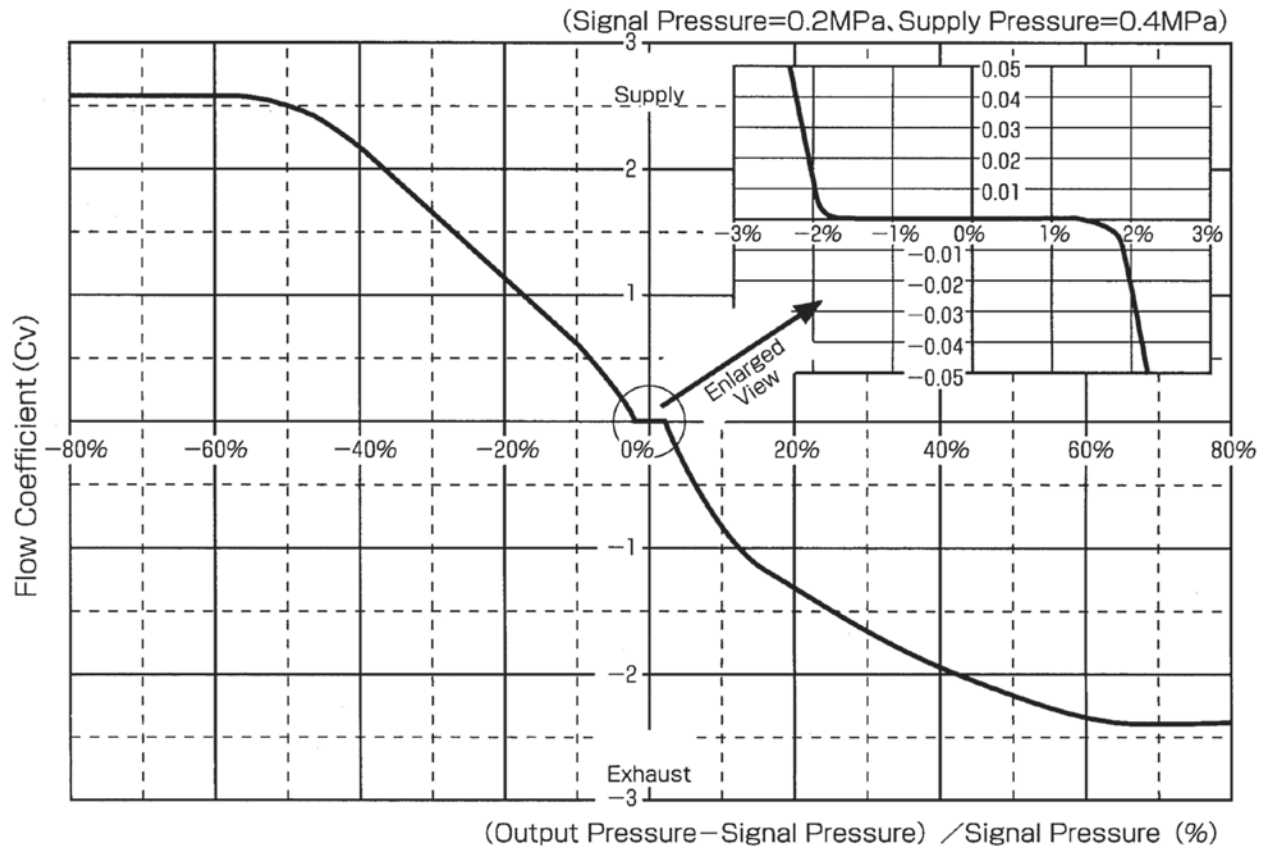

Figure 2 - Flow Characteristics

Operation

Prior to applying supply pressure to the relay, open the bypass needle valve approximately one turn. After applying pressure, note response of actuator to open and close commands from the positioner. If excessive overshoot or hunting is seen, open needle valve until stable operation is obtained. If valve is sluggish, close needle valve until unstable operation occurs, then back off until stable operation is obtained.

Turning valve clockwise (closing) speeds response but can lead to instability. Turning valve counterclockwise aids stability but will slow down the actuator's response. Proper setting provides stable operation and acceptable response time.

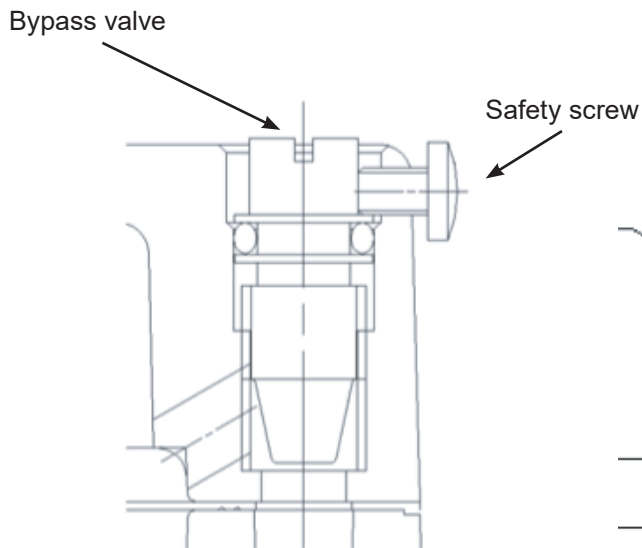

Figure 3
Bypass valve adjustment on BR200 model

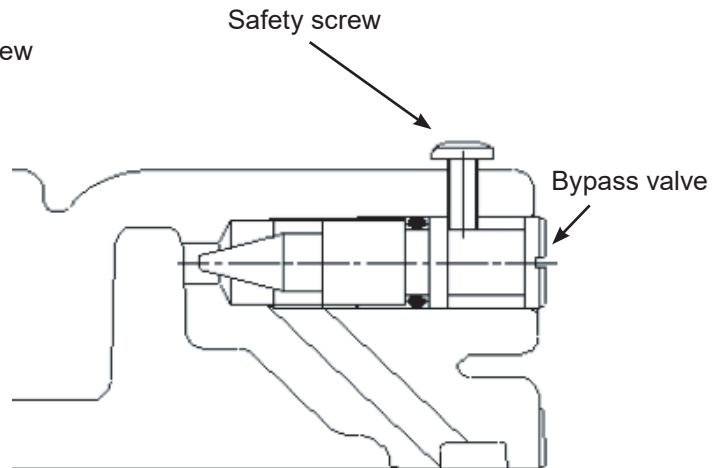

Figure 4
Bypass valve adjustment on BR400 model



Break loose of bypass valve:

Completely loose small screw and turn bypass valve near the fully opened position may cause bypass valve to break loose by internal pressure



Adjustment of bypass valve during plant operation:

Adjusting bypass value when control valve is in service may generate sudden valve opening change or oscillation.

Maintenance

The BR400 Booster Relays do not require any routine maintenance. If a contaminated air supply has been used, then there may be need to clean the filters or disassemble the relay to clean the supply and exhaust seats and valves.

Troubleshooting

If the output pressure does not respond to changes in the input pressure, check that supply pressure is at proper value and that signal and supply filters are not plugged with foreign matter. Check also that supply and exhaust valve seats are clean.

If output pressure is not stable or is slow to respond, check setting of bypass needle valve. See bypass valve setting procedure under "Operation".

Material of Construction and Dimensions

Model BR200

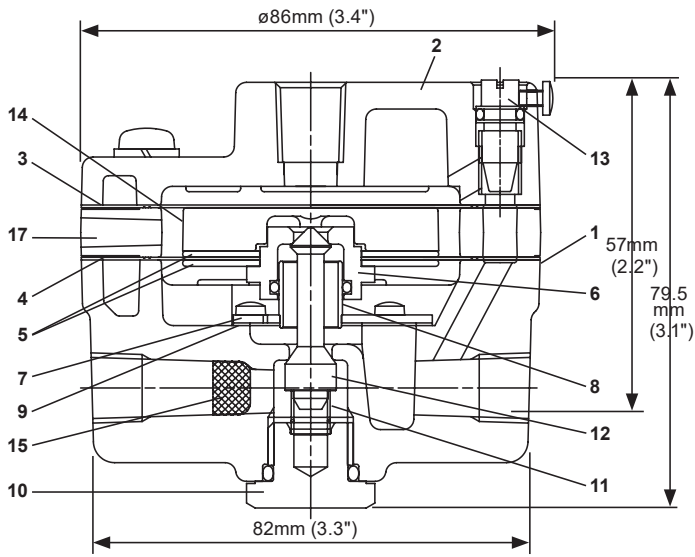

Figure 5 - BR200 Construction and Dimensions

No.	Part	Standard Material
1	Body	Aluminium Alloy Die Casting
2	Case	Aluminium Alloy Die Casting
3	Upper Diaphragm	Chloroprene / Polyester
4	Lower Diaphragm	Chloroprene / Polyester
5	Lower Diaphragm Plate	Aluminium Alloy Plate
6	Exhaust Seat	Copper Alloy
7	Seal Plate	Austenitic Stainless Steel
8	Exhaust Seal Guide	Copper Alloy
9	Seal Plate Gasket	Inorganic Fiber/Oil Resistant Synthetic Rubber
10	Plug Cap	Copper Alloy
11	Coil Spring	Austenitic Stainless Steel
12	Plug	Austenitic Stainless Steel
13	Bypass Valve Plug	Austenitic Stainless Steel
14	Piston	Glass Fiber Reinforced Thermoplastic Polyester
15	Supply Filter	Austenitic Stainless Steel
16	Signal Filter	Austenitic Stainless Steel
17	Bleed Ring	Aluminium Alloy Die Casting

Note: model BR400 is available in stainless steel for marine offshore applications.

Model BR400

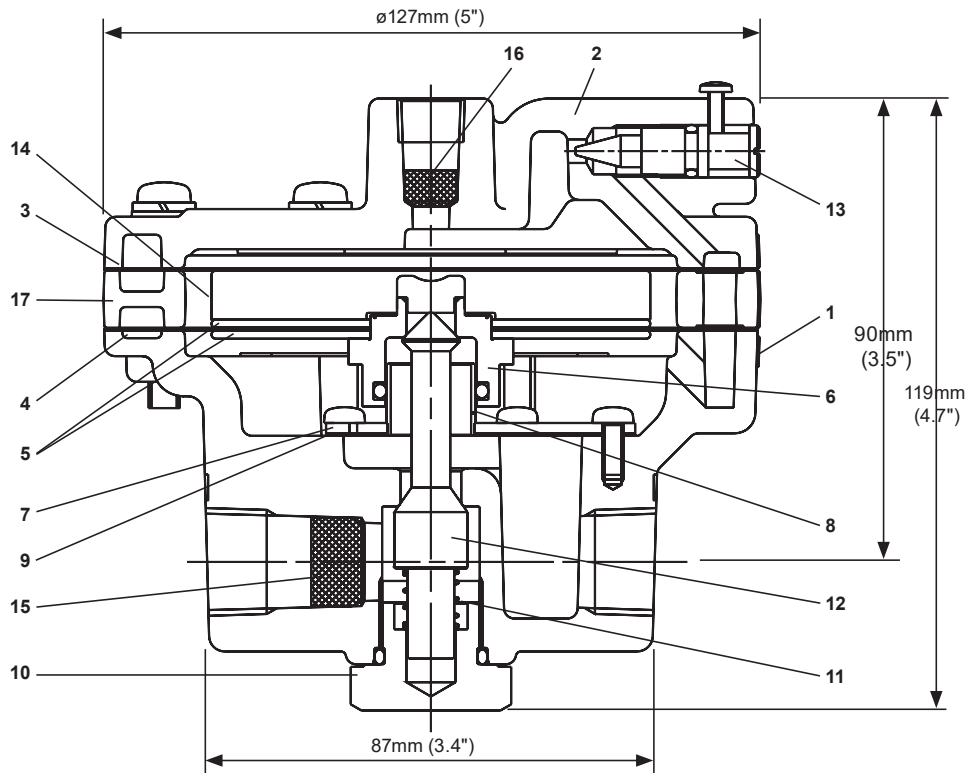

Figure 6 - BR400 Construction and Dimensions

Notes



CONTROLS SUPPLY CHAIN

VALVES ACTUATORS INSTRUMENTATIONS