



CONTROLS SUPPLY CHAIN
VALVES ACTUATORS INSTRUMENTATIONS

Elster Jeavons J125

Service Regulator

Inlet pressures up to 8.6bar



Commissioning Instructions

General Arrangements

Parts Lists

Maintenance Instructions

For: J125 MKII Regulator

1 1/2", 2" & 50mm size



J125: Commissioning Instructions

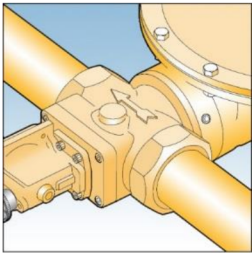

Fig. 1

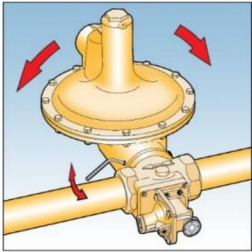

Fig. 2

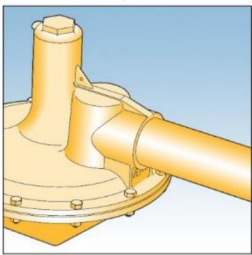

Fig. 3

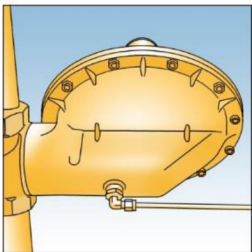

Fig. 4

OPERATING INSTRUCTIONS

- Ensure that this product is suitable for the chosen application.
- Installation, adjustment and maintenance by authorised, trained personnel only.
- When being fitted to an appliance, refer to the appliance manufacturers instructions.

Warning! Incorrect installation, adjustment, modification, operation and maintenance may cause injury or damage. Read the instructions before use. This control must be installed in accordance with the rules in force.

FITTING REGULATOR INTO PIPEWORK

1. The unit should not be installed in a corrosive environment.
2. The ambient temperature (surface temperature) should be within the limits stated on the regulator catalogue.
3. Check the maximum allowable pressure on the regulator nameplate against the installation specification.
4. Remove the protection plugs from inlet and outlet ports.
5. Ensure that installation pipework is thoroughly clean.
6. The direction of gas flow must be the same as arrows on regulator body. See Fig. 1.
7. Install the regulator into pipework using jointing compound approved to national standards.
8. In order to fit the regulator into confined spaces it may be necessary to rotate the diaphragm case. This is achieved by slacking off the three set screws, rotating the diaphragm case, and then re-tightening the set screws evenly. See Fig. 2.
9. For units with no OPSS fitted it is advised that a slam shut device is fitted to protect downstream equipment.

INSTALLATION OF VENT LINE.

1. Remove clip and vent screen from regulator top cover.
2. Connect the vent line (2"), using a jointing compound approved to national standards, and lead to atmosphere in accordance with national standards. Ensure that no water can penetrate vent pipeline. See Fig. 3.
3. If the regulator is fitted with an internal relief valve, ensure that the vent line is of sufficient diameter to carry gas vented by the relief valve to a safe outside location. Reference to any national standard.

INSTALLATION OF IMPULSE LINE

4. Remove the plastic protection plug.
5. Connect the impulse line (1/2"), using a jointing compound approved to national standards, and lead to a point downstream not less than fifteen times the nominal pipe diameter from the outlet. See Fig. 4.

FOR PRE-SET UNITS ONLY.

1. Turn off downstream valves.
2. Slowly turn on inlet supply.
3. If safety shut-off device is not fitted, go to instruction 6.



J125: Commissioning Instructions

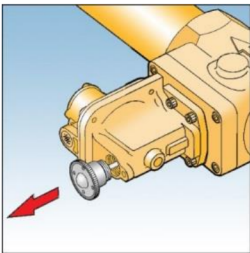

Fig. 5

4. If safety shut-off device is fitted unscrew reset spindle end cap and firmly pull. Hold in this position until the outlet pipework is fully pressurized, then release reset spindle end cap gently. See Fig. 5.
5. Re-screw reset spindle end cap into body, ensuring not to jam reset spindle.
6. Commission downstream appliances.

WARNING: DO NOT UNDER ANY CIRCUMSTANCES WEDGE OPEN SAFETY SHUT-OFF RESET END CAP AS THIS WILL NOT ALLOW THE SAFETY DEVICE(S) TO FUNCTION IN ADVERSE PRESSURE CONDITIONS.

SETTING THE REGULATOR & SAFETY SHUT OFF DEVICE PRESSURES.

OPSS = Over Pressure Safety Shut-off.

UPSS = Under Pressure Safety Shut-off.

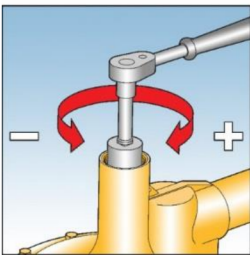

Fig. 6

1. Turn off inlet and outlet valves.
2. Remove top cap from regulator cover.
3. Insert an 1¼" A/F socket over the top of the adjustment screw.
4. Turn anticlockwise (-) to reduce loading on regulator spring to minimum. See Fig. 6 (If no safety devices are fitted go to instruction 10).

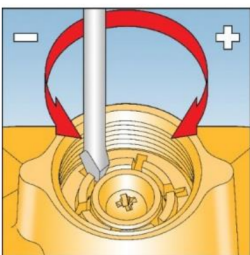

Fig. 7

5. Remove top cap from safety shut-off device cover (If UPSS only go to instruction 8).
6. Insert a flat bladed screwdriver into one of the partial slots on the OPSS spring holder. See Fig. 7.
7. Turn clockwise (+) to increase loading on OPSS spring to maximum.
8. If UPSS fitted, insert a pozidriv screw driver (No.2 point) into UPSS adjusting screw in bottom spring holder. See Fig. 8.
9. Turn anticlockwise (-) to reduce loading on UPSS spring, making sure screw head does not protrude from the bottom spring holder.
10. Slowly open inlet valve(s).
11. If safety device fitted, re-cock by unscrewing reset spindle end cap and pulling firmly. Hold in this position until the outlet pipework is fully pressurised, then release reset spindle end cap gently. Re-screw reset spindle end cap into body. See Fig. 5.
12. Turn regulator adjustment screw clockwise (+) to increase the loading on the spring until the required outlet pressure, plus approximately 2.5mbar (1"wg) is obtained. (This is an allowance for the regulator being set with zero flowrate).

If UPSS only go to instruction 20, if no safety device go to instruction 27.

13. Block vent valve opening to prevent relief valve from operating.
14. Apply external pressure source to a suitable point on the outlet pipework. Increase pressure to that required for OPSS trip-off.

Note: If pressure test point on underside of slam shut unit is used as external source point, care must be taken to ensure pressures are equalised across restricted orifice within test point.

15. Slowly turn OPSS spring holder anticlockwise (-) until OPSS device trips off. See Fig. 7.
16. Reduce external pressure source to level set in instruction 12.

J125: Commissioning Instructions

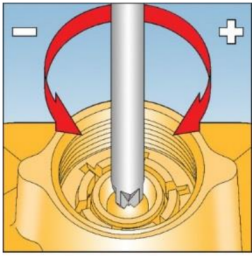

Fig. 8

17. Re-cock OPSS device by unscrewing reset spindle end cap and firmly pull. Hold in this position until the outlet pipework is fully pressurized, then release reset spindle end cap gently. Re-screw reset spindle end cap into body. See Fig. 9.

18. Slowly increase external pressure to check for OPSS trip-off. Trim adjustment if necessary and repeat instructions 16 - 18.

19. Remove external pressure source.

NOTE: OPSS device is now set.

20. Close inlet valves.

21. Reduce inlet pressure to approximately 140mbar (2 PSI).

22. Reduce outlet pressure by introducing a slow controlled bleed until the required UPSS trip-off pressure is obtained and close bleed.

23. Slowly turn UPSS adjusting screw clockwise (+) until UPSS device trips off. See Fig. 8.

24. Slowly open inlet valve to regain inlet pressure up to approximately 140mbar (2 PSI), then close inlet valve.

25. Re-cock UPSS device by unscrewing reset spindle end cap and firmly pull. Hold in this position until the outlet pipework is fully pressurised, then release reset spindle end cap gently. Re-screw reset spindle end cap into body. See Fig. 9.

26. Slowly reduce outlet pressure to check for UPSS trip-off. Trim adjustment if necessary and repeat instructions 24 – 26.

NOTE: UPSS device is now set.

27. Commission installations.

28. Trim the regulator outlet pressure if necessary once normal flow rates have been achieved.

29. Unblock vent opening.

30. Replace all top caps (seal if necessary).

WARNING: DO NOT UNDER ANY CIRCUMSTANCES WEDGE OPEN SAFETY SHUT-OFF RESET END CAP AS THIS WILL NOT ALLOW THE SAFETY DEVICE(S) TO FUNCTION IN ADVERSE PRESSURE CONDITIONS.

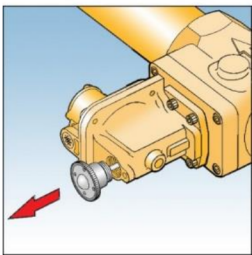

Fig. 9



J125: Commissioning Instructions

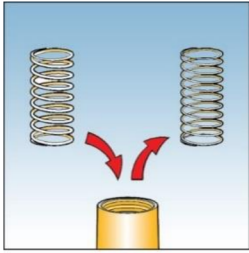

Fig. 10

IF THE REQUIRED REGULATOR OUTLET PRESSURE CANNOT BE ACHIEVED WITH THE SPRING FITTED

1. Remove top cap from regulator cover.
2. Choose a loading spring from catalogue or page 17 that will give the required outlet pressure range.
3. Fully unscrew and remove the spring holder, See Fig. 11.
4. Remove spring and replace with new one. See Fig. 10.
5. Screw spring holder back in place, ensuring regulator spring is located in recess in underside of holder.
6. Adjust the outlet pressure as described previously.
7. Replace the top cap (seal if necessary).

NOTE: Outlet pressure is now set

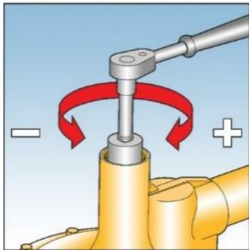

Fig. 11

IF THE REQUIRED TRIP-OFF PRESSURES CANNOT BE ACHIEVED WITH THE SPRINGS FITTED

A) OPSS spring

1. Remove top cap from the safety shut-off device cover.
2. Choose an OPSS spring from the catalogue or page 17 that will give the required pressure range.
3. Fully unscrew and remove top spring holder. See Fig. 11.
4. Remove spring and replace with new one. See Fig. 9.
5. Screw spring holder back in place, ensuring that castellated spigot is uppermost in chimney. See Fig. 11.
6. Adjust the trip-off pressure as described previously.
7. Replace the top cap (seal if necessary).

NOTE: OPSS pressure is now set

B) UPSS spring.

1. Remove top cap from the safety shut-off device cover.
2. Choose an UPSS spring from the catalogue or page 17 that will give the required pressure range.
3. Fully unscrew and remove top spring holder. See Fig. 12.
4. Remove OPSS spring (or spacer tube if UPSS only).

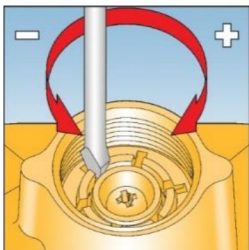

Fig. 12



J125: Commissioning Instructions

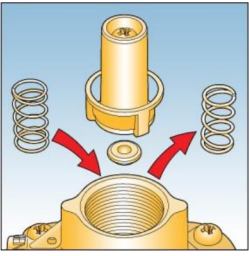

Fig. 12

5. Remove bottom spring holder and UPSS top spring holder.
6. Remove UPSS spring and replace with new one. See Fig. 12.
7. Replace UPSS spring holder, ensuring that spigot locates in UPSS spring.
8. Replace bottom spring holder locating three webs into slots in bottom of cover, ensuring not to disturb UPSS spring and UPSS spring holder.
9. Replace OPSS spring (or spacer tube if UPSS only).
10. Screw top spring holder back in place, ensuring that castellated spigot is uppermost in chimney. See Fig. 11. (If UPSS only ensure that spacer tube is firmly clamped)
11. Adjust the trip-off pressure as described previously
12. Replace the top cap (seal if necessary).

NOTE: UPSS pressure is now set.



J125: General Arrangement

S1, S2, S3 Assembly – Fig 14

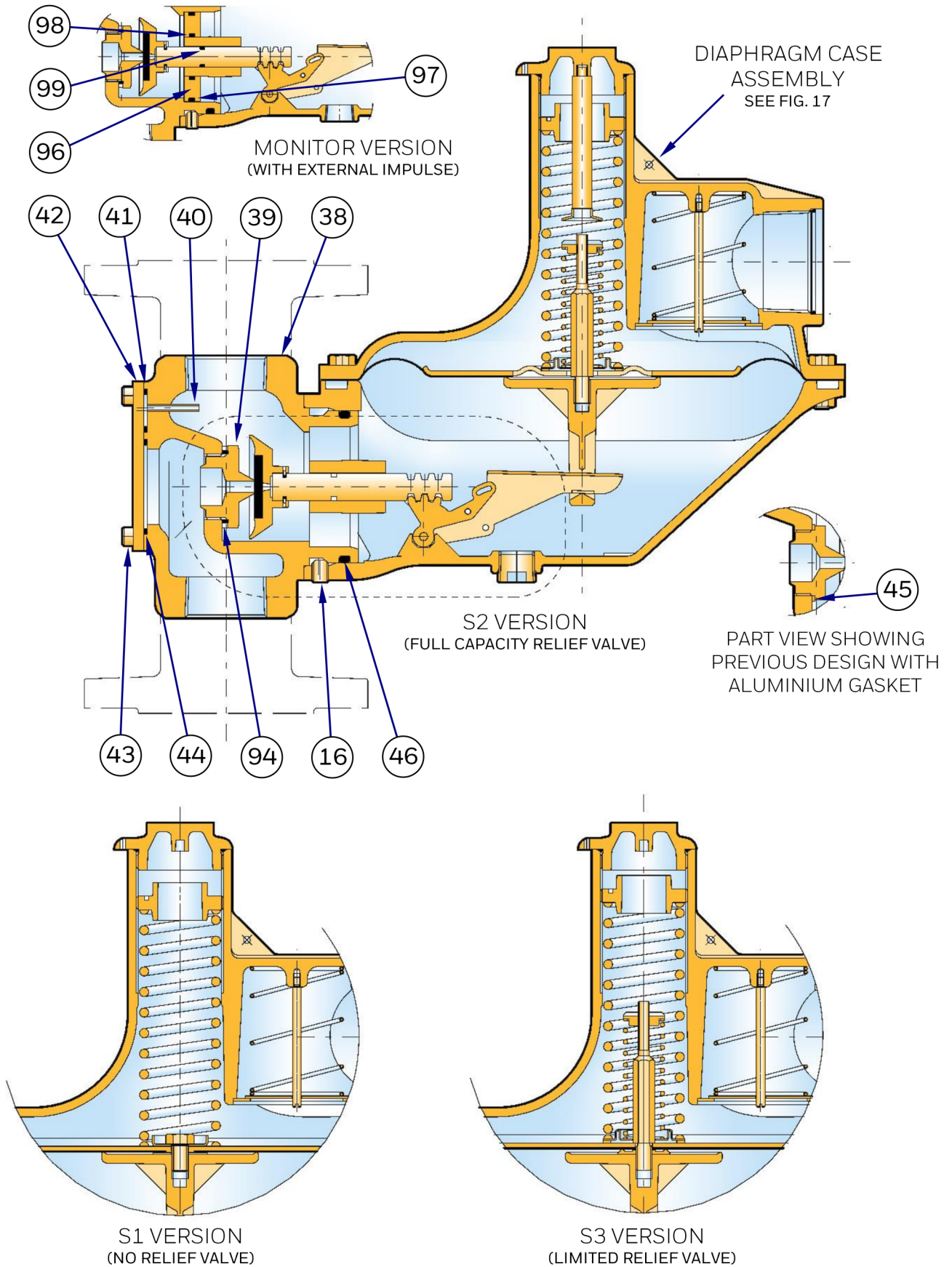



J125: General Arrangement

S4, S5, S10 Assembly- Fig 15

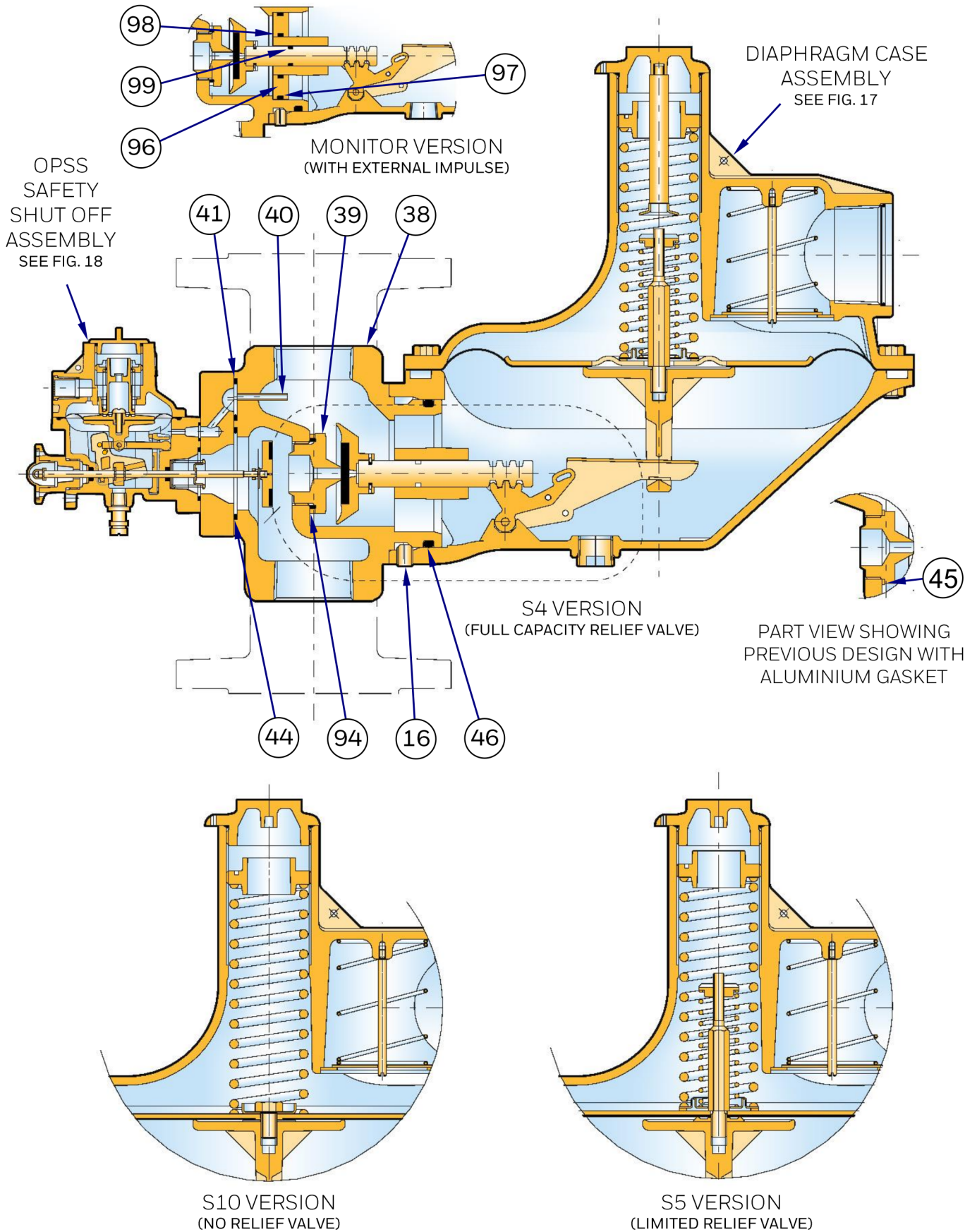



J125: General Arrangement

S6, S7, S8, S9, S11, S12 Assembly- Fig 16

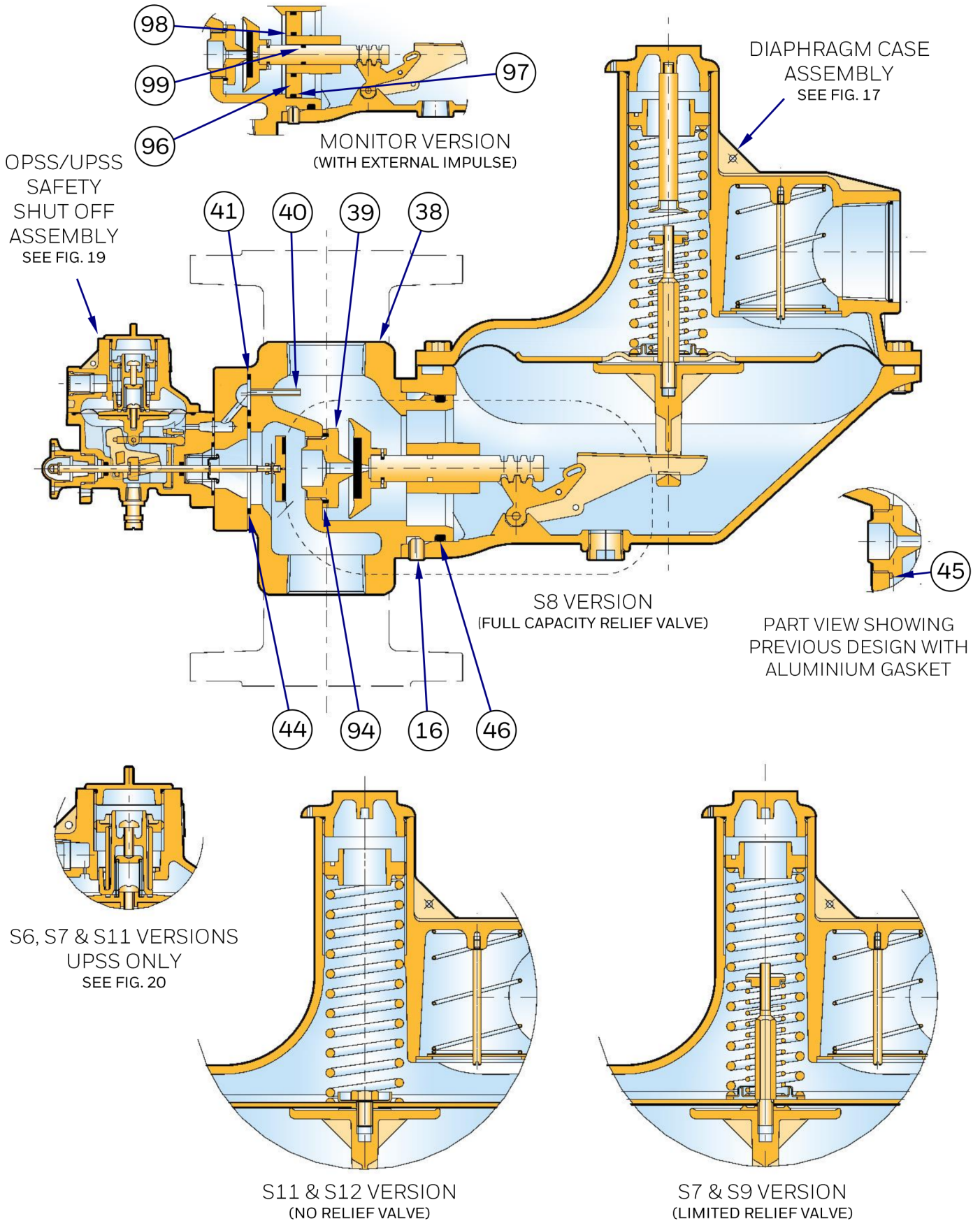



J125: General Arrangement Diaphragm Case Assembly – Fig 17

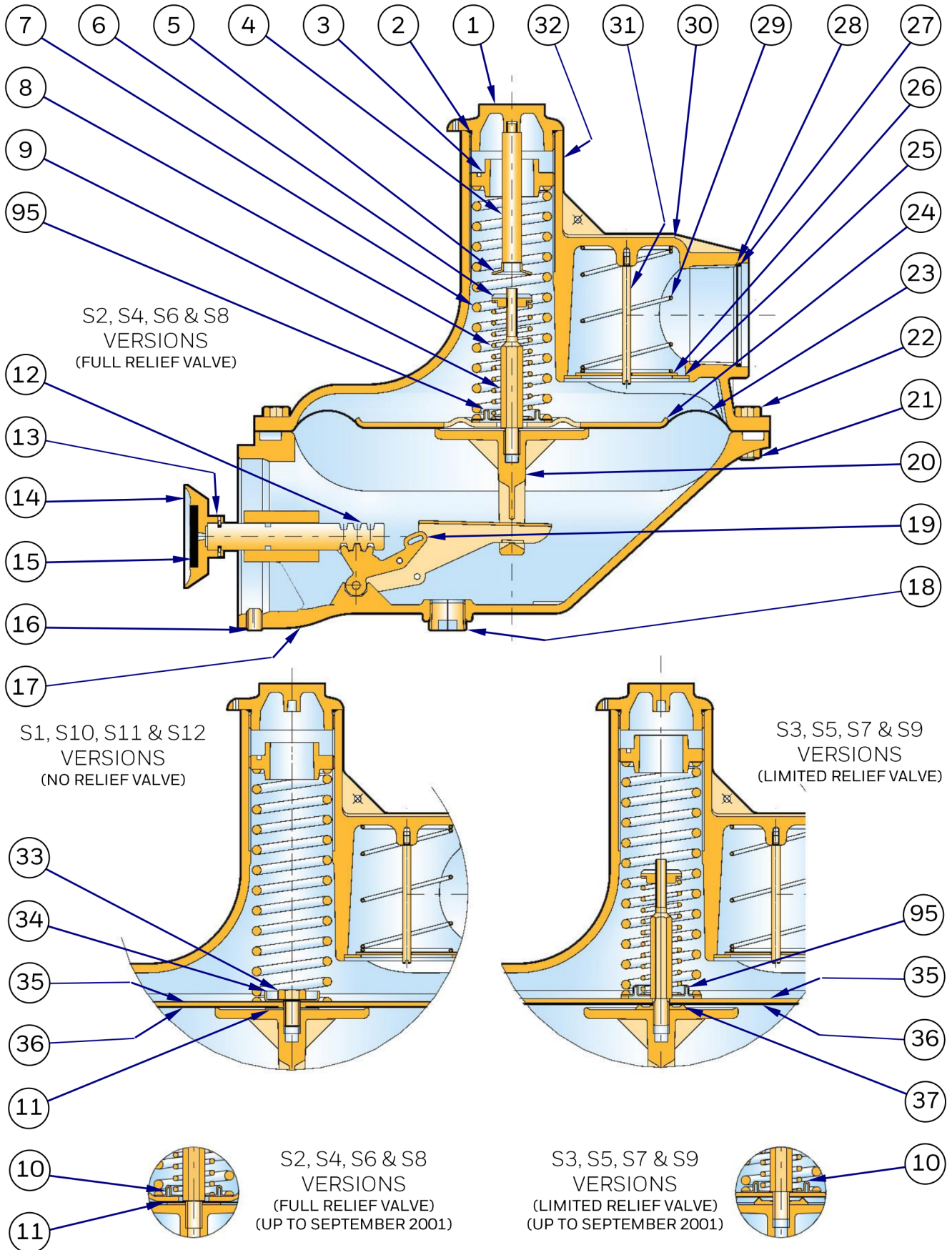



J125: General Arrangement

OPSS Safety Shut Off Assembly – Fig 18

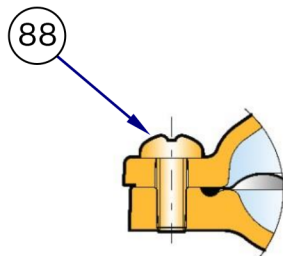
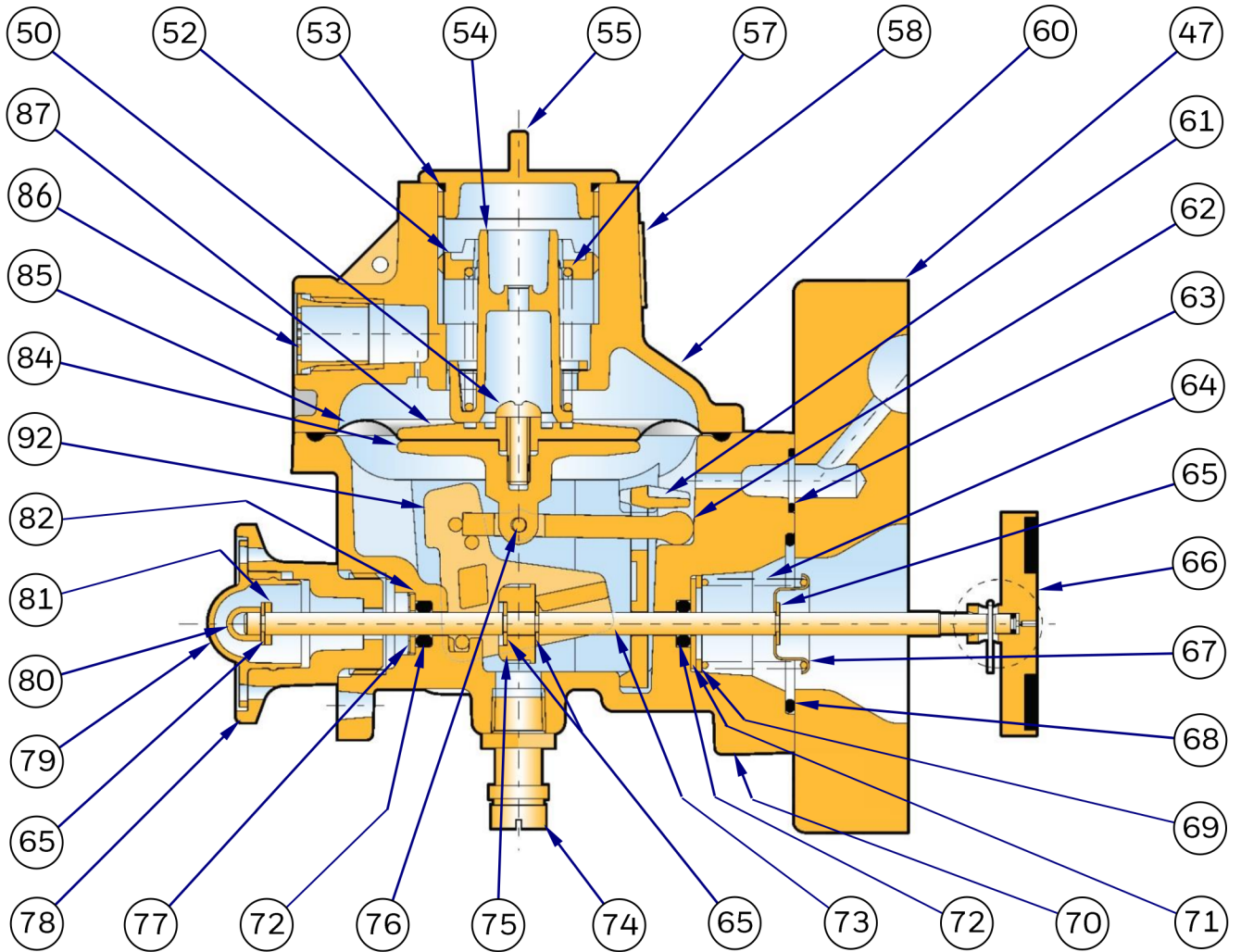

TOP COVER TO
BODY FIXING

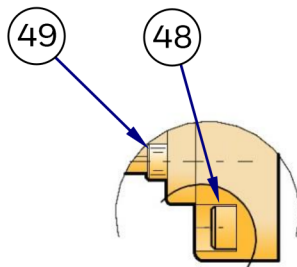

OPSS BODY TO
ADAPTOR PLATE
FIXING

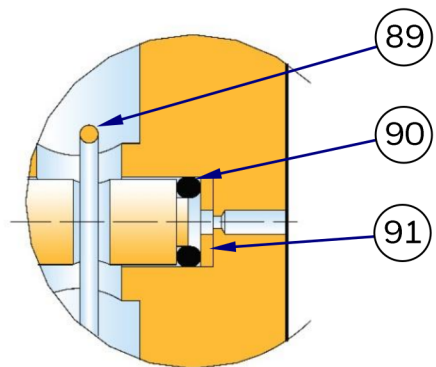

ENLARGED VIEW
OF VALVE DISC



J125: General Arrangement

OPSS/UPSS Safety Shut Off Assembly – Fig 19

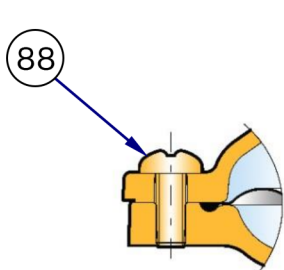
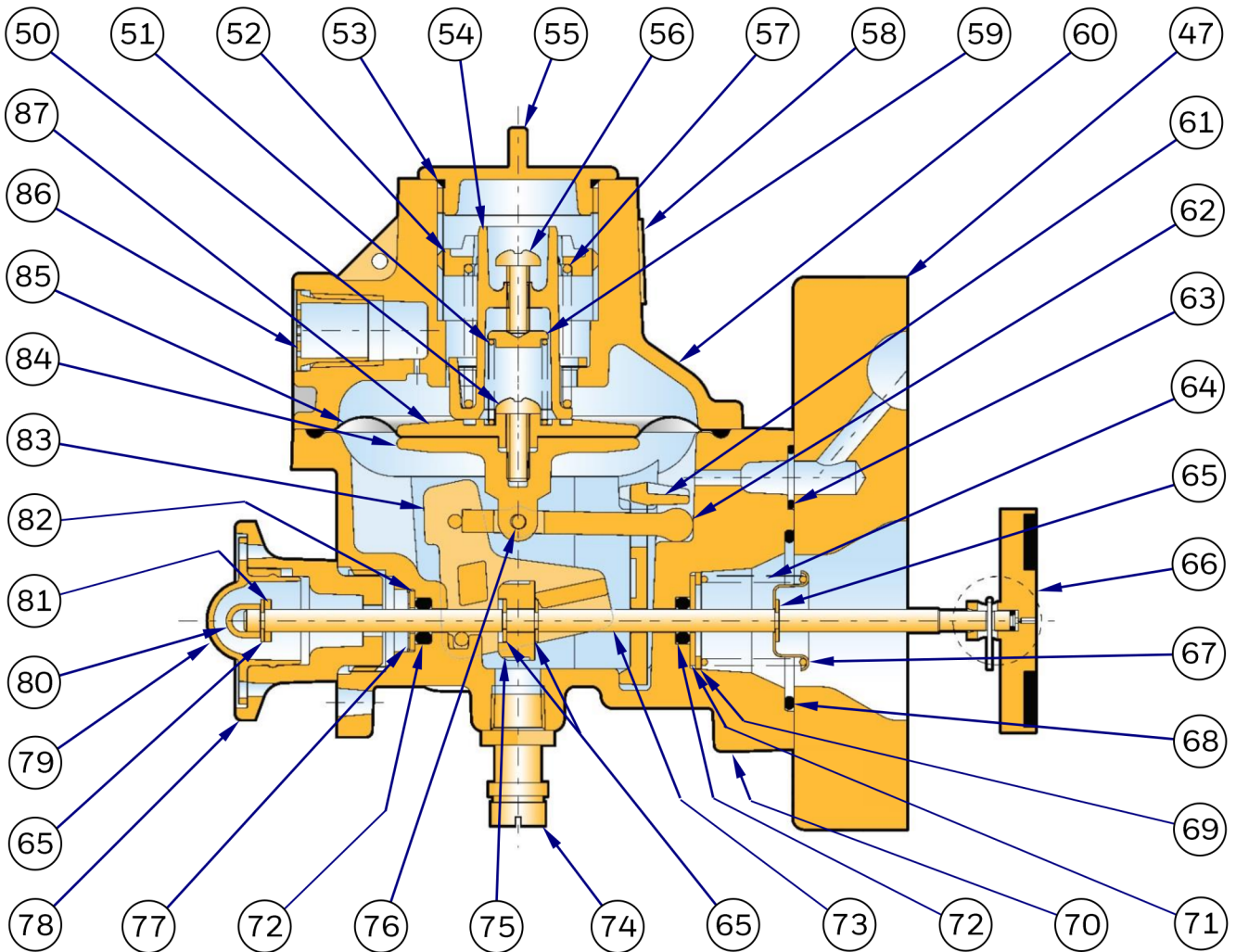

TOP COVER TO
BODY FIXING

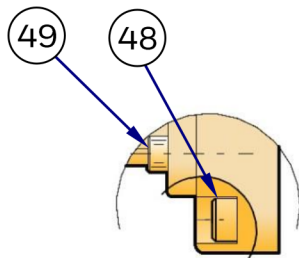

OPSS BODY TO
ADAPTOR PLATE
FIXING

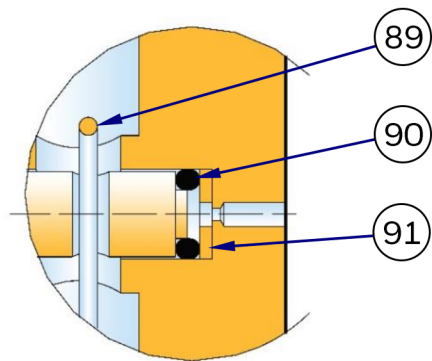

ENLARGED VIEW
OF VALVE DISC



J125: General Arrangement

UPSS Safety Shut Off Assembly – Fig 20

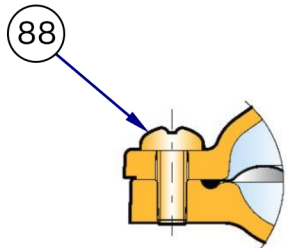
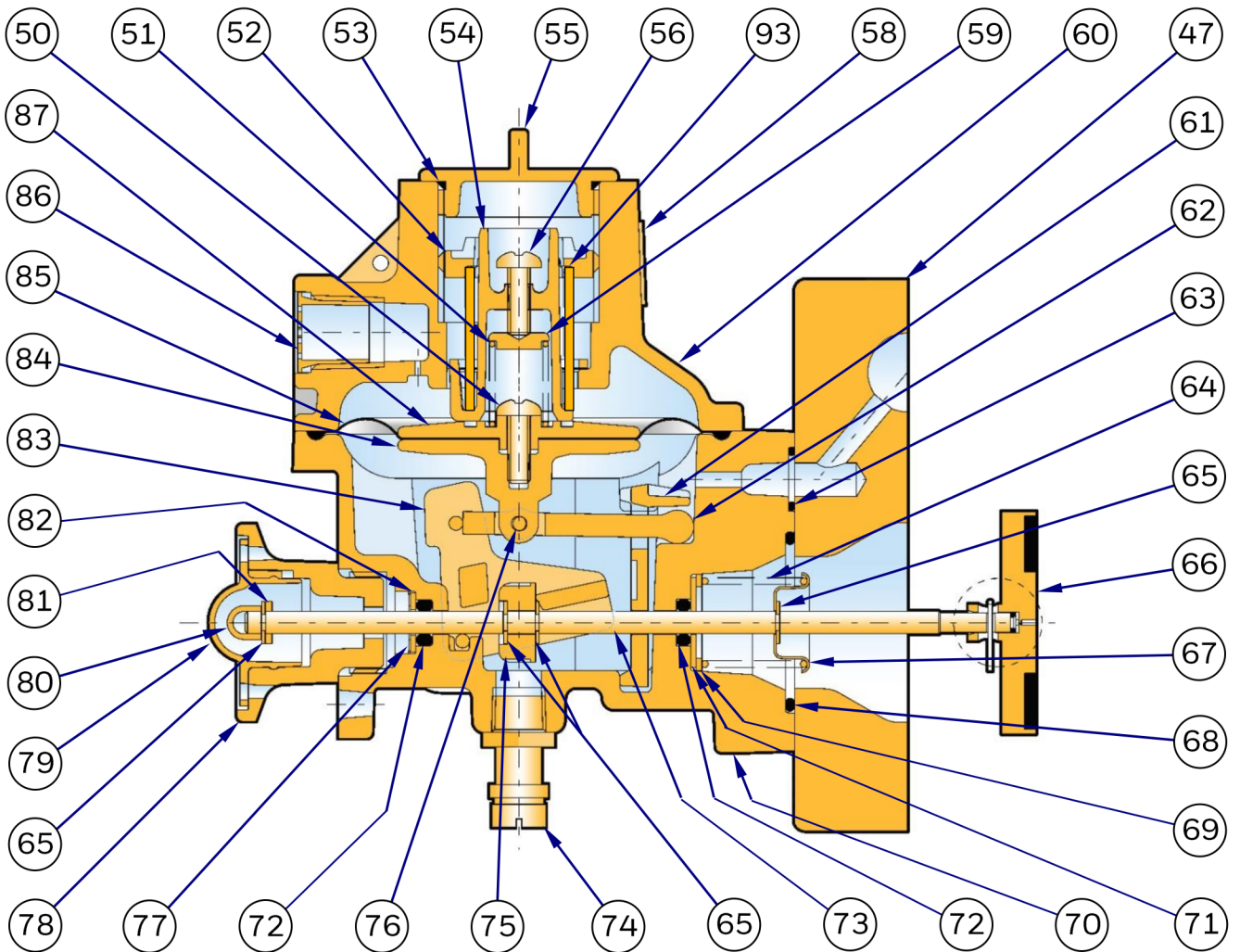

TOP COVER TO BODY
FIXING

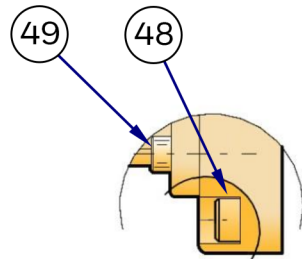

OPSS BODY TO
ADAPTOR PLATE
FIXING

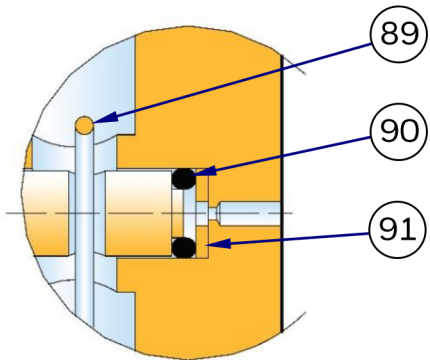

ENLARGED VIEW OF
VALVE DISC



J125: Parts List

ITEM	DESCRIPTION	PART NUMBER	No. Off
1	TOP CAP	I70103P001	1
2	"O" RING (TOP CAP)	JOBS133	*1
3	ADJUSTMENT SCREW	I73183P001	1
4	ROD STOP	I73056P001	1
5	FLANGE STOP ROD	I73174P001	1
6	SPRING ADJUSTING NUT	I71533P001	1
7	LOADING SPRING	SEE TABLE	1
8	RELIEF VALVE SPRING	I70017P074	1
9	RELIEF VALVE STEM	I73058P001	1
10	SPRING LOCATOR (Up to September 2001)	I73175P001	1
11	FLAT WASHER (No Relief) <small>(Full & No Relief up to Sept 01) Not used since 2009</small>	I13981P076	1
12	VALVE PLUNGER	I72627P001	1
13	RETAINER CLIP	I72858P001	*1
14	SEAT DISC HOLDER (FOR USE WITH J12509-122 BELOW)	I72624P001	1
15	VALVE SEAT DISC (VITON MATERIAL, COLOURED GREEN)	J12509-122	1
	VALVE ASSEMBLY (NITRILE MATERIAL, COLOURED BLACK)	I73026G005	*1
16	SOCKET GRUB SCREW	JSA1012SONSS	3
17	REGULATOR DIAPHRAGM CASE	J12509-123 (+ if tapped)	1
18	PLUG (C/Sunk Recess 1/2" BSP Galvanised)	JMFP2G04 (if fitted)	1
	PLUG (C/Sunk Recess 1/2" NPT Galvanised)	I11970P031 (if fitted)	1
19	LEVER ASSEMBLY	I72626P002	1
20	DIAPHRAGM STEM	I72629P005	1
21	HEXAGON NUT	JNA8FZD	12
22	SCREW HEX HEAD	JSA825HHNZG	12
23	DIAPHRAGM (Full Relief)	J12509-116	*1
24	DIAPHRAGM PLATE (Full Relief)	I73057P002	*1
25	VENT VALVE SEAT	J12509-028	1
26	VENT VALVE DISC	J12509-029	1
27	VENT SCREEN SPRING CLIP	J12509-038	1
28	VENT SCREEN	J12509-037	1
29	VENT VALVE SPRING	J12509-060	1
30	TOP COVER	J12509-079 +	1
31	VENT VALVE GUIDE PIN	J12509-042	1
32	NAMEPLATE	J8112-124	1
33	HEX CAP SCREW	JSNEIHHNZR	1
34	SPRING GUIDE	I72272P001	1
35	DIAPHRAGM PLATE (No / Limited Relief)	J12509-126	*1
	DIAPHRAGM PLATE (No / Limited Relief) <small>before July 2014</small>	I70012P052	1
36	DIAPHRAGM (No / Limited Relief)	J12509-115	*1
37	RELIEF VALVE CUP	I73054P002	1



J125: Parts List

Continued

ITEM	DESCRIPTION	PART NUMBER	No. Off
38	SCREWED BODY 1½"	J12508-080 +	1
	SCREWED BODY 2"	J12509-080 +	1
	FLANGED BODY 50mm	J12509-081 +	1
39	VALVE SEAT	SEE TABLE	1
40	IMPULSE TUBE SCREWED	J12509-112	1
	IMPULSE TUBE FLANGED	J12509-111	1
41	"O" RING	JORM0195-30	*1
42	BLANKING PLATE	J12509-083	1
43	SCREW (Blanking Plate)	JSA616SANSS	4
44	"O" RING	JORM0495-30	*1
45	GASKET (Aluminium) (For Bonded Seal see Item 94)	I70019P094	*1
46	"O" RING	JOBS338	*1
47	ADAPTOR PLATE (USSA)	J12509-082Z02	1
48	SCREW (Adaptor Plate/Regulator Body)	JSA620SANSS	4
49	SCREW (OPSS Body/Adaptor Plate)	JSA516SANSS	4
50	SCREW (Shut-off Diaphragm)	JSA412XPTZ	1
51	UPSS SPRING	SEE TABLE	1
52	SAFETY SHUT OFF SPRING HOLDER	J12506-248	1
53	"O" RING (Safety Shut Off Top Cap)	JORM0251-16	*1
54	BOTTOM SPRING HOLDER	J12506-250	1
55	SAFETY SHUT OFF TOP CAP	J12506-142	1
56	SCREW (UPSS Adjustment)	JSA412XPTZ	1
57	OPSS SPRING	SEE TABLE	1
58	SAFETY SHUT-OFF NAMEPLATE	J150D-076	1
59	UPSS SPRING HOLDER	J12506-249	1
60	SAFETY SHUT-OFF TOP COVER	J12506-240 +	1
61	TRIP-OFF LEVER RETAINING PLATE	J12506-243	1
62	TRIP-OFF LEVER	J12506-242	1
63	"O" RING (Impulse Passage) Replaces JORM0081-16D	03110340	*1
64	VALVE SPRING	J12506-049	1
65	CIRCLIP VALVE SPINDLE	03627606	*4
66	VALVE DISC (Moulded)	J12509-109M	1
67	VALVE SPRING CUP	J12506-251	1
68	"O" RING (Safety Shut off /Adaptor Plate)	JORM0276-24	1
69	CIRCLIP (Front "O" Ring Washer)	JCIR2000K-17B	1
70	SAFETY SHUT OFF BODY	J12506-239 +	1
71	FRONT "O" RING RETAINING WASHER	J12506-252	1
72	"O" RING for Shut-Off Spindle (to end of 2005)	JOBS105D	*2
	"O" RING for Shut-Off Spindle (from start 2006)	JO4-25	*2



J125: Parts List

Continued

ITEM	DESCRIPTION	PART NUMBER	No. Off
73	SAFETY SHUT-OFF VALVE SPINDLE	J12509-110	1
74	PRESSURE TEST NIPPLE	JPTN01-0.71	1
75	TRIP-OFF BUSH	J12506-244	1
76	NEEDLE ROLLER	JNR02S	1
77	STARLOCK WASHER	JCIR1305-043B	1
78	RESET SPINDLE END CAP	J12506-254	1
79	COVER (Spindle End Cap)	J12506-255	1
80	INDICATOR CAP (Safety Shut Off)	JCLOSEMC4	1
81	WASHER-REAR (circlip protection)	J12506-292	1
82	REAR "O" RING RETAINING WASHER	J12506-253	*1
83	TRIP-OFF LATCH (OPSS / UPSS and UPSS only)	J12506-241	1
84	LOWER DIAPHRAGM PLATE	J12506-247	1
85	SAFETY SHUT-OFF DIAPHRAGM	J12506-246	*1
86	VENT SCREEN	J12506-277	1
87	TOP DIAPHRAGM PLATE	J12506-245	1
88	SCREW (Top Cover/Body)	JSA512TPTS	4
89	"R" CLIP VALVE	33470076	*1
90	"O" RING SEAL	JO200606-4475D	*1
91	GASKET VALVE	J12506-267	*1
92	TRIP-OFF LATCH (OPSS only)	J12506-322	1
93	UPSS SPACER TUBE	J12506-279	1
94	BONDED SEAL (Replaces Aluminium Gasket see Item 45)	JBSMB45017	*1
95	SPRING LOCATOR ASSEMBLY (From October 2001)	I73175G001	1
96	ISOLATION PLATE	I73010P002	1
97	"O" RING SEAL	JOBS230	*1
98	"O" RING SEAL	JOBS217	*1
99	"O" RING SEAL	JOBS111	*1

NOTES: Items marked * are contained in spares kits (See table below).
Part Numbers ending with + require connection information.

VALVE SEATS

ORIFICE SIZE	PART NUMBER
¼" – 6.35mm	J12509-101
⅜" – 9.5mm	J12509-102
½" – 12.7mm	J12509-103
⅝" – 15.9mm	J12509-104
¾" – 19.1mm	J12509-105
⅞" – 22.2mm	J12509-106
1" – 25.4mm	J12509-107
1¼" – 31.8mm	J12509-108



J125: Spring Tables

REGULATOR SPRINGS

mb.	"w.g.	PART NUMBER	COLOUR
8.8 - 15	3.5 - 6	J12509-091	RED
14 - 20	5.5 - 8	J12509-092	ORANGE
21 - 35	8.5 - 14	J12509-093	YELLOW
36 - 70	14.5 - 28	J12509-094	GREEN
69 - 138	1 - 2 PSI	J12509-095	ROYAL BLUE
104 - 173	1.5 - 2.5 PSI	J12509-096	BROWN - ROYAL BLUE
138 - 207	2 - 3 PSI	J12509-097	BROWN - GREEN
207 - 345	3 - 5 PSI	J12506-098	BLACK - GREEN

OVER PRESSURE SLAM-SHUT SPRINGS

mb.	"w.g.	PART NUMBER	COLOUR
18 - 60	7.5 - 24	J12506-281	BLACK
50 - 80	20 - 32	J12506-282	ORANGE
60 - 110	24 - 44	J12506-283	RED
100 - 210	40 - 84	J12506-284	DARK GREEN
200 - 350	3 - 5 PSI	J12506-287	YELLOW
280 - 500	4 - 7 PSI	J12506-288	WHITE

UNDER PRESSURE SLAM-SHUT SPRINGS

mb.	"w.g.	PART NUMBER	COLOUR
8 - 16	3 - 6	J12506-285	LIGHT BLUE
16 - 60	6 - 24	J12506-286	BROWN
60 - 150	24 - 60	J12506-289	PURPLE

NOTE: A minimum differential of 30mb must be maintained between OPSS and UPSS set pressures

SPARES KITS

REGULATOR TYPE	SPARES KIT PART NUMBER
J125-S1 & S3	SK2529-01
J125-S2	SK2529-02
J125-S4, S6 & S8	SK2529-03
J125-S5, S7, S9, S10, S11 & S12	SK2529-04

J125: Maintenance Instructions

Regulator Body

Drawing Reference: Figs. 14, 15 & 16

NOTE: Numbers in brackets identify items on drawings

Regulator Dismantling Procedure.

1. Check external surfaces for excessive corrosion.
2. Disconnect diaphragm case assembly from regulator body (38) by removing the three grub screws (16), gently pull out the case from the regulator body (38).
3. Disconnect the safety shut-off unit assembly, or blanking plate (42), from the regulator body (38) by removing the four cap screws (43) or (48).
4. Remove valve seat (39) assembly from the regulator body (38).
5. Remove bonded seal (94) or gasket (45) from valve seat (39) assembly. Note: the old design valve seat assembly with gasket (45) was glued into body (38).
6. Wipe clean the valve seat (39) assembly, check for any damage and take note of whether bonded seal (94) or aluminium gasket (45) is fitted to the valve seat.
7. Check that the impulse tube (40) is clear. DO NOT REMOVE TUBE FROM BODY.

Regulator Rebuilding Procedure.

NOTE: Inspect all sealing "O" rings, and replace where necessary (a soft spares kit is available for this purpose, see page 17).

The use of Molykote 111 "O" ring lubricant is recommended during the rebuild- unless for use with oxygen when no lubricant should be used.

1. If, when the valve seat (39) assembly was dismantled, the bonded seal (94) was fitted, then replace with a new bonded seal (94). DO NOT USE ALUMINIUM GASKET (45).
2. If, when the valve seat (39) assembly was dismantled, the aluminium gasket (45) was fitted, then replace with new aluminium gasket (45). DO NOT USE WITH BONDED SEAL (94). Note: The bonded seal (94) and aluminium gasket (94) CANNOT be interchanged with each other, due to valve seat (39) being a different length and this may affect unit performance and safety.
3. Refit valve seat (39) assembly into regulator body (38) by screwing it in until metal contact is made.
4. Fit new "O" ring (46) onto diaphragm case assembly and apply "O" ring lubricant.
5. Insert diaphragm case assembly into regulator body (38) being careful not to damage the "O" ring, secure in place with three grub screws (16).
6. Replace "O" rings (41) and (44) into regulator (38) making sure the contact surfaces are clean and the "O" rings are lubricated.
7. Locate and secure the safety shut-off assembly, or blanking plate (42), in place using four cap screws (43) or (48).
8. Test unit for gas tightness.
9. Commission unit as described on pages 2 - 6.

J125: Maintenance Instructions

Diaphragm Case

Drawing Reference: Figs. 17

NOTE: Numbers in brackets identify items on drawings

Diaphragm Case Dismantling Procedure.

1. Unscrew top cap (1) and remove "O" ring (2).
2. Unscrew and remove adjusting screw (3) and loading spring (7).
3. Remove top cover (30) by unscrewing the 12 nuts (21) and screws (22).

NOTE: It is not recommended to strip down the Vent Valve Assembly items: (25), (26), (29) & (31).

For Relief Versions go to instruction 6.

4. Remove diaphragm assembly (35), from the diaphragm case (17).
5. Unscrew the hexagon cap screw (33) from the diaphragm assembly (35) to allow assembly to be dismantled.

For No Relief Version go to instruction 9.

6. Prior to dismantling the relief valve assembly, measure the height "h" of the relief valve spring (8). The spring will have to be compressed to the same dimension on reassembly.

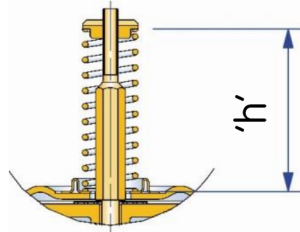

7. Remove diaphragm assembly (Full Relief) (23) or (Limited Relief) (35), and relief assembly from the diaphragm case (17).
8. Unscrew spring adjusting nut (6) from Diaphragm assembly (23) or (35) to allow assembly to be dismantled.
9. Using a pair of pliers, remove retaining clip (13), so valve assembly (14) can be removed from valve plunger (12).
10. Withdraw isolation plate (96) and remove "O" rings (97 & 98) – monitor version only.
11. Valve plunger (12) and lever assembly (19) can be removed from the diaphragm case (17).
12. Remove "O" ring (98) from valve plunger (12) – monitor version only.

Diaphragm Case Rebuilding Procedure.

NOTE: Inspect all sealing "O" rings, diaphragms and gaskets and replace where necessary (a soft spares kit is available for this purpose see page 17).

1. Check main diaphragm (23) or (36) for signs of damage, if necessary replace with a new diaphragm assembly (23) + (24) or (35) + (36).
2. Check that sealing surfaces on the diaphragm (23) + (36) and diaphragm stem (20) are clean.

For Relief versions go to instruction 7.

3. Push cap screw (33) through centre hole of spring guide (34) with lip facing screw head.
4. Now push cap screw (33) through centre hole of diaphragm assembly (35) + (36), with diaphragm plate lip facing spring guide (34).
5. Replace flat washer (11) over cap screw (33).
6. Screw diaphragm stem (20) onto cap screw (33) securing diaphragm assembly.

For No Relief version go to instruction 18.



J125: Maintenance Instructions

Diaphragm Case Rebuilding Procedure Continued

For Full & Limited Relief units built after September 2001 go to instruction 11.

Full & Limited Relief units before October 2001

7. (Full Relief Version): Replace flat washer (11), over centre hole in diaphragm stem (20).
(Limited Relief Version): Replace relief cup (37) with projections facing upwards, over centre hole of the diaphragm stem (20).
8. Screw relief valve stem (9) into diaphragm stem (20).
9. Place diaphragm assembly (full relief (23) + (24)) or (limited relief (35) + (36)) with diaphragm plate lip facing upwards, on top of relief cup (37) or flat washer (11).
10. Replace spring locator (10) with convolution facing upwards, over relief valve stem (9). We now go to Instruction 16.

Full & Limited Relief units after September 2001

11. (Limited Relief Version): Replace relief cup (37) with projections facing upwards, over centre hole of the diaphragm stem (20).
12. Screw relief valve stem (9) into diaphragm stem (20).
13. (Limited Relief Version): Place diaphragm assembly (35) + (36) with diaphragm plate lip facing upwards, on top of relief cup (37).
14. (Full Relief Version): Place diaphragm assembly (23) + (24) with diaphragm plate lip facing upwards, on top of relief valve stem (9).
15. Replace spring locator (95) with convolution facing upwards, over relief valve stem (9).
16. Place relief spring (8) over relief valve stem (9).
17. Screw relief spring adjusting nut (6) with spigot located in relief spring (8), onto relief valve stem (9). Screw relief adjusting nut (6) to the required height "h", as measured during dismantling, see instructions (page 19).
18. Place lever assembly (19) into the slot in the diaphragm case (17).
19. Check valve disc (15) and valve disc holder (14) for damage and excessive wear, if necessary replace with a new assembly.
20. Fit "O" rings (97 & 98) onto isolation plate (96) and refit to diaphragm case (17) – monitor only.
21. Refit valve disc assembly on to valve plunger (12) using retainer clip (13).
22. Push valve plunger (12)[fitted with "O" ring (99) – monitor version only] through hole in the diaphragm case (17) and engage grooves into teeth in lever assembly (19).
23. Relocate the main diaphragm / relief valve assembly into position. Make sure of the following:
 - (a) The lever assembly (19) is fitted correctly into the slot in the diaphragm stem (20).
 - (b) The holes in the diaphragm (23) or (36) and diaphragm case (17) are aligned correctly.
24. Check that the vent valve in the top cover (30) moves freely.
25. Replace top cover (30) on top of diaphragm case (17) taking care not to damage diaphragm (23) or (36), and secure in place using 12 screws (22) and nuts (21).
26. Place loading spring (7) into chimney of top cover (30).
27. With slot in adjusting screw (3) facing upwards, screw adjusting screw (3) into the chimney of the top cover (30), so that it locates on loading spring (7).
28. For Full Relief Version only: Screw rod stop assembly (4) and (5) into top cap (1).
29. Replace "O" ring (12) onto top cap (1).
30. Screw top cap (1) into chimney of top cover (30).
31. Screw 3 grub screws (16) into case (17).
32. Refit screen (28) and clip (27) into vent.
For reassembly to body see page 18.

J125: Maintenance Instructions

Safety Shut Off Units

Drawing Reference: Figs. 18, 19 & 20

NOTE: Numbers in brackets identify items on drawings

Safety Shut-off Dismantling Procedures.

1. Unscrew top cap (55) and remove "O" ring (53).
2. Unscrew and remove top spring holder (52) together with OPSS spring (57), or UPSS spacer tube (93).
3. Remove bottom spring holder (54) together with UPSS screw (56) if fitted.
DO NOT REMOVE UPSS SCREW (56).
4. Remove top cover (60) by unscrewing the four screws (88).
5. If fitted remove UPSS spring holder (59) together with UPSS spring (51).
6. Lift diaphragm assembly from body (70).
7. Unscrew diaphragm clamping screw (50) and remove top diaphragm plate (87) and main diaphragm (85).
8. Remove needle roller (76) to release lever arm (62) from lower diaphragm plate (84).
9. Remove "R" clip (89) from spindle (73). Valve (66) (with "O" ring (90) and gasket (91) inside) can now be removed. Push valve spring cup (67) towards body (70) and remove circlip (65). Valve spring cup (67) and valve spring (64) can now be withdrawn.
10. Remove four screws (49) securing USSA body (70) to adaptor plate (47).
11. Remove "O" rings (63) and (68) from USSA body (70).
12. Unscrew reset spindle end cap (78) and pull out until it comes to a stop.
13. Inside the body prise visible circlip (65) from valve spindle (73) to release trip-off bush (75).
14. Slide trip-off bush (75) forward and prise second circlip (65) from valve spindle (73).
15. Withdraw valve spindle (73) and end cap assembly (65), (78), (79), (80) & (81) from body (70).
16. Remove trip-off lever retaining plate (61), trip-off bush (75) and trip-off latch (83) or (92).
17. Remove circlip (69), front "O" ring retaining washer (71) and front "O" ring (72).

NOTE : It is not recommended to interfere with the rear "O" ring (72) unless absolutely necessary. A new "O" ring and starlock washer should be refitted if dismantled.

18. Remove starlock washer (77), rear "O" ring retaining washer (82) and rear "O" ring (72) from body (70).
19. It is not necessary to remove test point (74).



J125: Maintenance Instructions

Safety Shut Off Units - Continued

Safety Shut-off Rebuilding Procedures.

NOTE: Inspect all sealing "O" rings, diaphragms and gaskets and replace where necessary (a soft spares kit is available for this purpose see page 17).

The use of Molykote 111 "O" ring lubricant is recommended during the rebuild- unless for use with oxygen when no lubricant should be used.

1. Fit new "O" ring (72) into rear "O" ring groove in body (70) and apply "O" ring lubricant. Replace rear "O" ring retaining washer (82) and secure with new starlock washer (77), making sure starlock washer is central in bore.
2. Locate lever retaining plate (61) into recesses in body (70).
3. Position trip-off bush (75) with slots engaged with rails of trip-off latch (83) or (92) and arrow facing away from steel needle rollers. Relocate assembly into body (70) making sure that the needle roller is correctly positioned in raised recess in body (70).
4. Push valve spindle (73) and cap assembly (65),(78),(79),(80) & (81) through rear of body (70), trip-off bush (75), lever retaining plate (61) and front of body (70).
5. Slide trip-off bush (75) up against lever retaining plate (61) and fit a new circlip (65) into groove on valve spindle (73) furthest away from trip-off bush (75).
6. Slide trip-off bush (75) back against 1st circlip (65) and fit a 2nd new circlip (65) to groove on valve spindle (73) which clamps trip-off bush (75) to valve spindle (73).
7. Fit new "O" ring (72) into front "O" ring groove in body (70) and apply "O" ring lubricant, replace front "O" ring retaining washer (71) and secure firmly with new circlip (69).
8. Replace valve spring (64) into front face of body (70).
9. Locate valve spring cup (67) over spindle (73) and into valve spring (64)
10. Push valve spring cup (67) to compress valve spring (64) until circlip (65) can be assembled into groove in spindle (73) nearest body (70).
11. Fit new "O" rings (63) and (68) into grooves in front face of body (70).
12. Reassemble adaptor plate (47) to body (70) and secure with four screws (49).
13. Place gasket (91) into centre hole of valve (66). Insert "O" ring (90) into centre hole of valve (66).
14. Push valve assembly (66) over spindle (73), align hole in valve (66) and spindle (73), assemble together with "R" clip (89).
15. Align hole in diaphragm (85) with convolution upper most, with hole in lower diaphragm plate (84). Locate spigot of top diaphragm plate (87) through diaphragm (85) and into recess in lower diaphragm plate (84). Secure with diaphragm clamping screw (50).
16. Position slot in lever arm (62) over spigot on lower diaphragm plate (84) and align holes, replace needle roller (76) through holes.
17. Unscrew reset end cap (78) and withdraw it, until it comes to a stop.
18. Locate diaphragm assembly and lever arm (62) into recess between lever retaining plate (61) and body (70), ensuring bead of diaphragm (85) locates into groove in body (70).



J125: Maintenance Instructions

Safety Shut Off Units - Continued

Safety Shut-off Rebuilding Procedures – Continued

19. Replace bottom spring holder (54) together with UPSS screw (56) if fitted, into chimney of top cover (60) by aligning ribs of bottom spring holder (54) with slots in top cover (60).
20. Replace OPSS spring (57), or UPSS spacer tube (93), into bottom spring holder (54).
21. Screw top spring holder (52) into chimney of top cover (60) ensuring that castellated spigot is uppermost. If UPSS spacer tube (93) is fitted, screw top spring holder (52) down firmly.
22. If fitted locate UPSS spring (51) into recess in top diaphragm plate (87), refit UPSS spring holder (59) ensuring that spigot locates in UPSS spring (51).
23. Replace top cover assembly (60) and secure with four screws (88), ensuring UPSS spring arrangement (51) and (59) if fitted is undisturbed. Take care not to pinch diaphragm bead (85).
24. Fit new "O" ring (53) to top cap (55) and screw into chimney of top cover (60).
25. If removed, replace test point (74).
26. For reassembly to body see page 18.



Honeywell is committed to a programme of continuous quality enhancement. All equipment designed and manufactured within Honeywell benefits from the groups quality assurance standards, which are approved to EN ISO9001.

Honeywell has a programme of continuous product development and improvement and in consequence the information in this leaflet may be subject to change or modification without notice.