



Elster Jeavons J48



For
J48 MKII Regulator $\frac{3}{4}$ " , & 2"
J48 MKII Angled Regulator $\frac{3}{4}$ " , & 2"
J48 MKII Meter Regulator $\frac{3}{4}$ " , & 2"

M481EN | 08/01/17



Index

Commissioning Instructions	3
General Arrangement	4
Parts List	7
Spare & Loading Springs	9
Maintenance Instructions	10



Commissioning Instructions

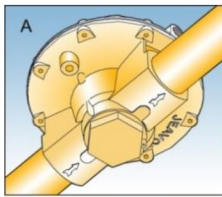

FITTING REGULATOR INTO PIPEWORK (A)

1. Remove the plastic protection plugs from inlet and outlet (and breather if applicable).
2. Ensure that installation pipework is thoroughly clean.
3. The direction of gas flow must be the same as the arrow(s) on the regulator body.
4. Install the regulator into pipework using a jointing compound approved to national standards.

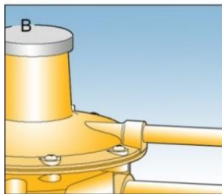

INSTALLATION OF VENT LINE (B) IF REQUIRED

5. Remove the plastic protection plug.
6. Connect the vent line (1/4" connection), using a jointing compound approved to national standards, and lead to atmosphere in accordance with national standards. Ensure that no water can penetrate vent pipeline.

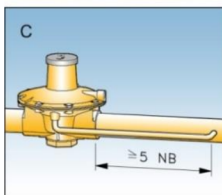

INSTALLATION OF EXTERNAL IMPULSE LINE (C) IF REQUIRED

7. Remove the plastic protection plug.
8. Connect the impulse line (1/8" connection), using a jointing compound approved to national standards, and lead to a point downstream not less than five times the nominal pipe diameter from the outlet.

FOR PRE - SET REGULATORS

9. Turn off downstream valves.
10. Slowly turn on inlet supply.
11. Commission downstream appliance(s).

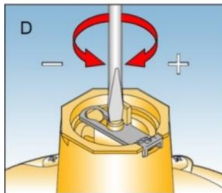

SETTING OF OUTLET PRESSURE (D)

12. Turn off downstream valves.
13. Remove the top cap.
14. Insert a flat bladed screwdriver into the slot in the end of the spring adjusting screw.
15. Turn anticlockwise to reduce pressure on the loading spring.
16. Slowly turn on inlet supply.
17. Increase loading on the spring by turning the spring adjusting screw clockwise until the required outlet pressure, plus approximately 2.5mbar, is obtained.
18. Commission downstream appliance(s).
19. Trim the outlet pressure of the regulator, if necessary, when normal working flow rates have been achieved.
20. Replace the top cap (and seal if necessary).

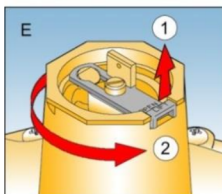

IF THE REQUIRED OUTLET PRESSURE CANNOT BE ACHIEVED WITH THE SPRING FITTED. (E) & (F).

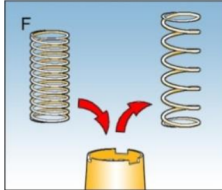

21. Choose a loading spring from the catalogue that will give the required outlet pressure range.
22. Turn spring adjusting screw anticlockwise (to reduce loading on spring).
23. Carefully lift protruding end of locking lever just clear of adjusting bush (1), whilst in this position turn (octagon shaped) adjusting bush assembly anticlockwise until disengaged (2). The adjusting bush assembly can then be removed from the top cover.
24. Remove the loading spring.
25. Insert the new spring - take the label from the spares kit bag and stick it below the nameplate of the regulator.
26. Screw top spring holder anticlockwise to within 10mm of underside of adjusting bush.
27. Position underside of top spring holder on to loading spring.
28. Align slots in top spring holder with splines in top cover and push adjusting bush assembly into top cover as far as possible.
29. Turn adjusting bush assembly clockwise until locking lever snaps into any of the three locking castellations in the top cover.
30. Adjust the outlet pressure, as described above, until the required setting is found.
31. Replace the top cap (and seal if necessary).



General Arrangement

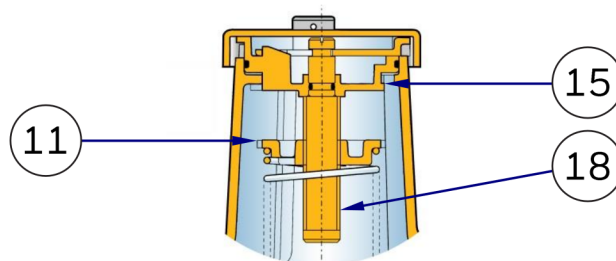
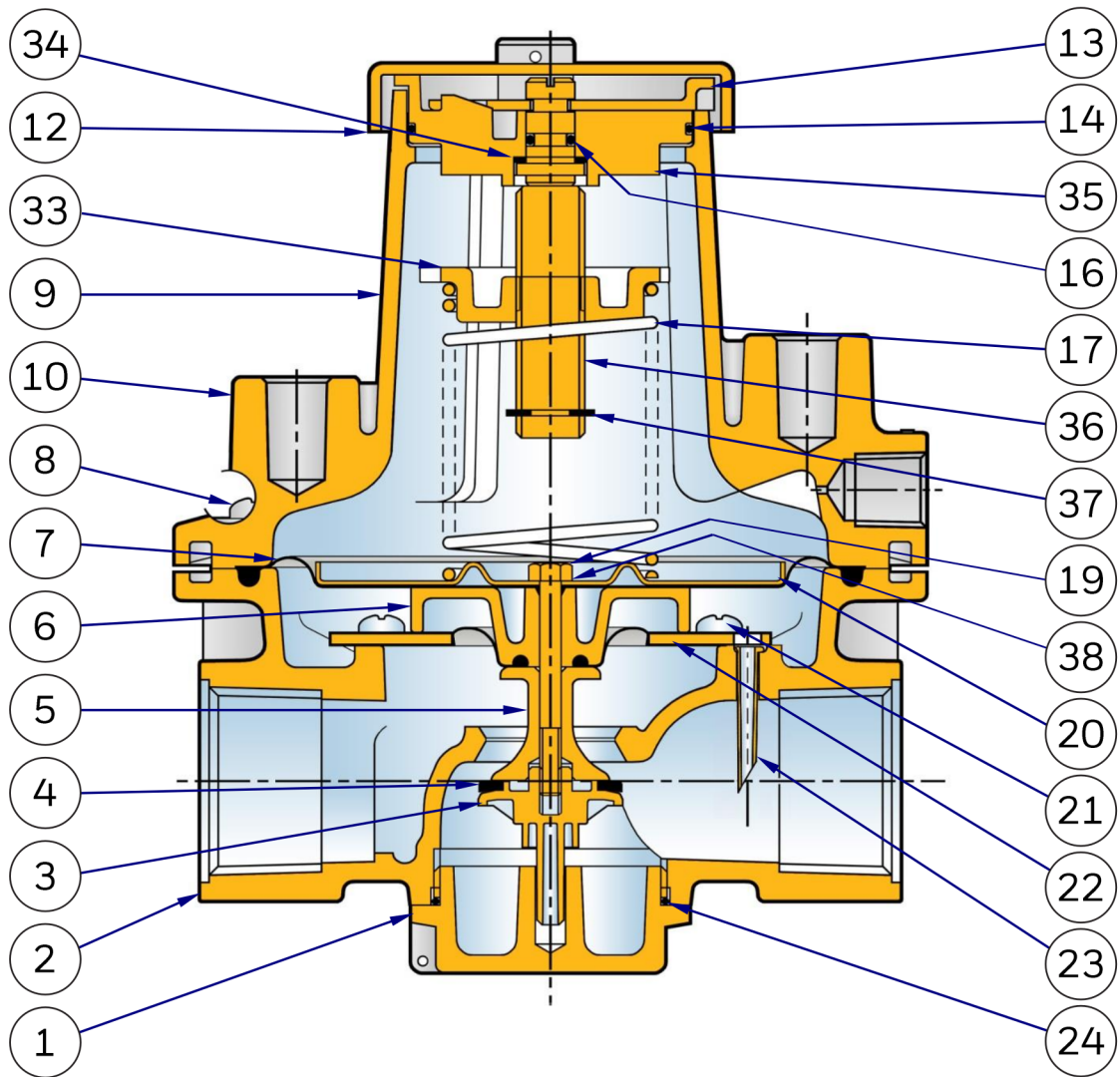

Spring Adjustment
Pre October 2000



General Arrangement

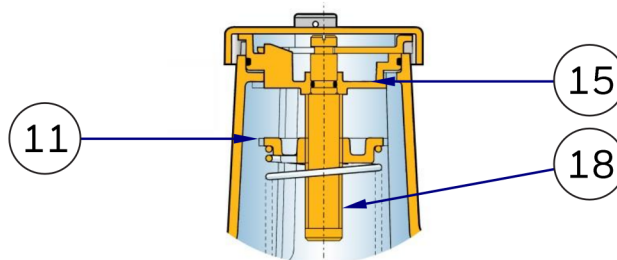
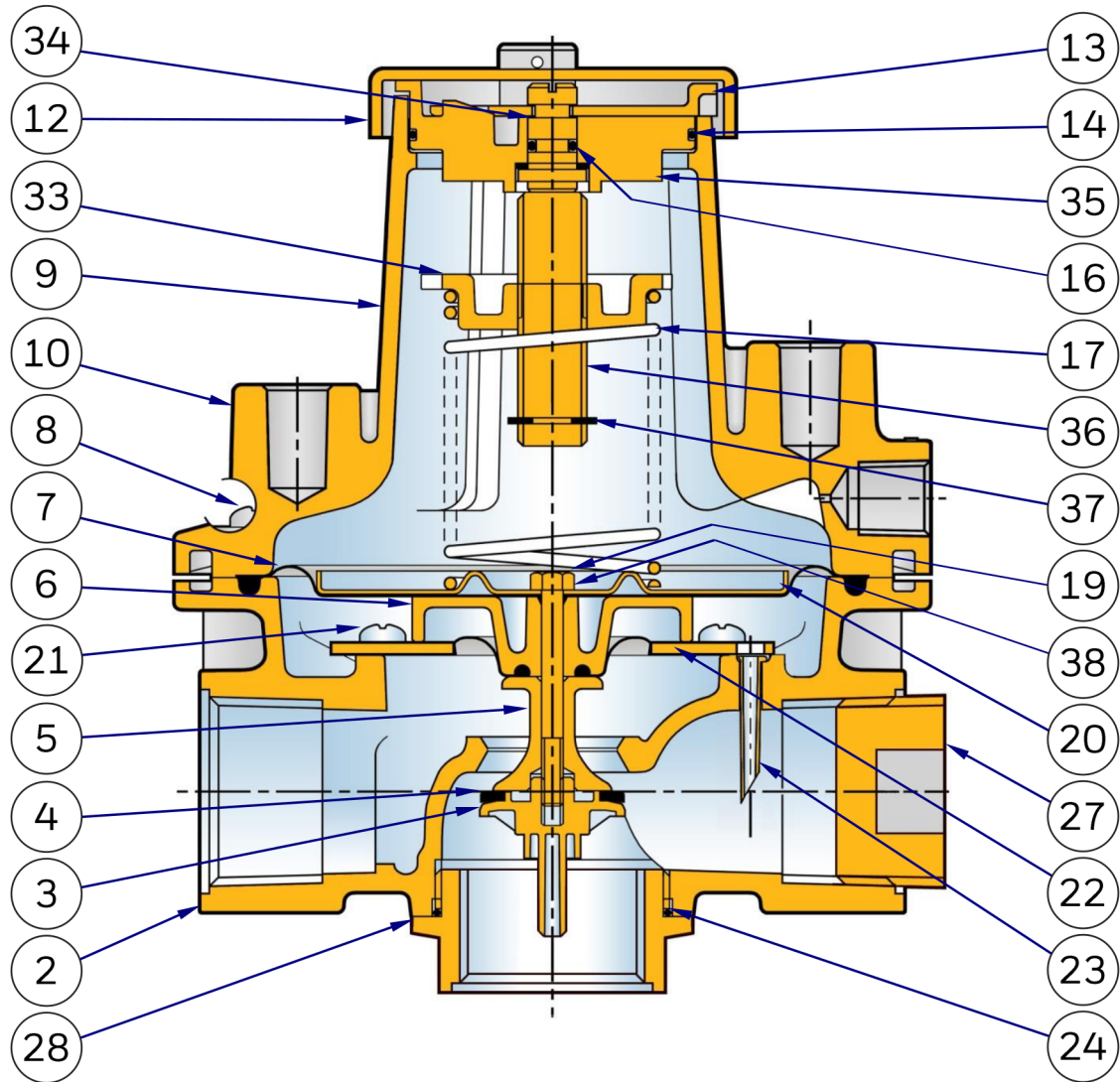

Spring Adjustment
Pre October 2000



General Arrangement

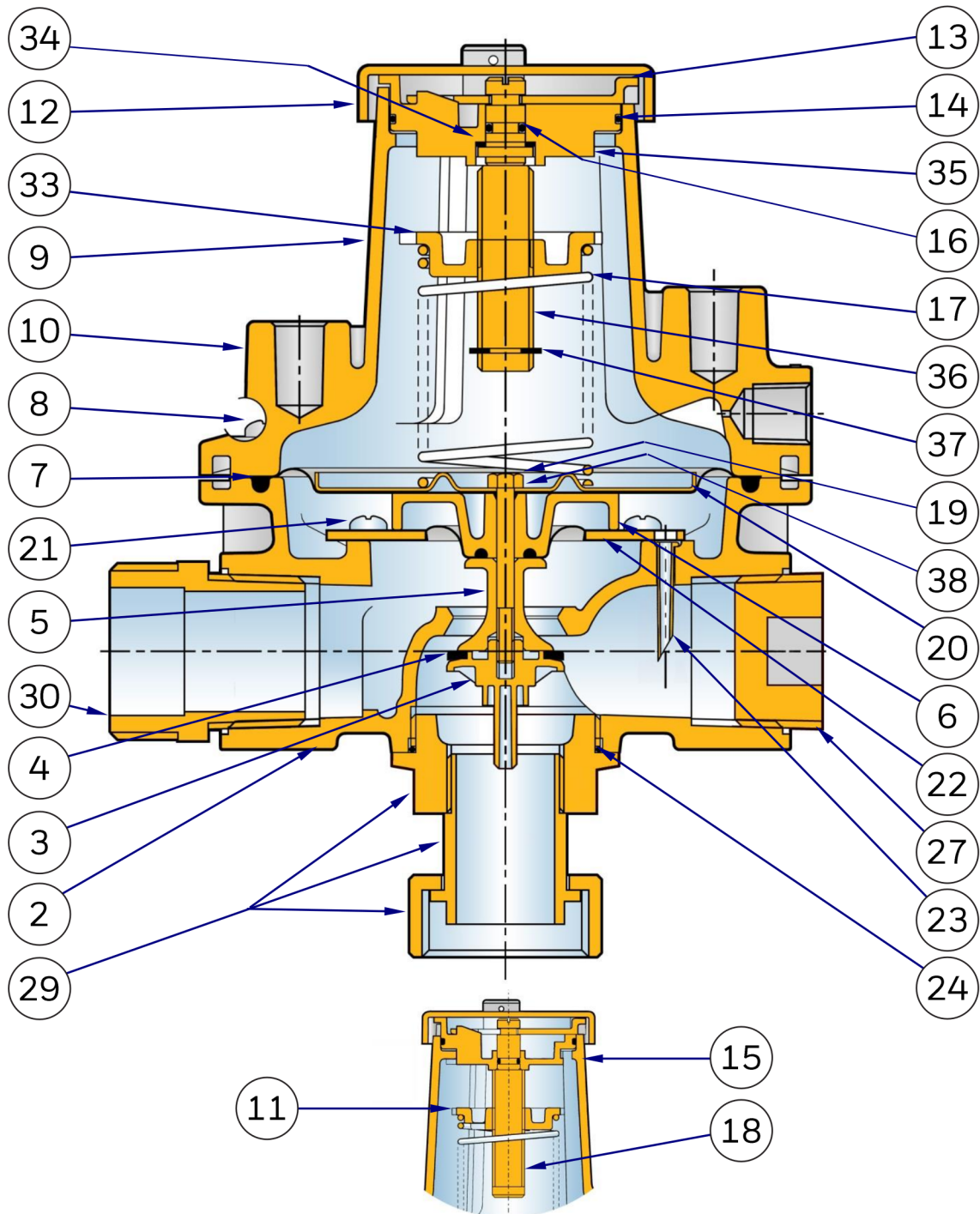

Spring Adjustment
Pre October 2000



Parts List

ITEM	DESCRIPTION	3/4"	No. Off	1"	No. Off
1	BOTTOM PLUG	J4806-017Z03	1	J4806-017Z03	1
3	BODY	J4805-005+	1	J4806-094+	1
3	VALVE DISC HOLDER	J4806-015	1	J4806-015	1
4	VALVE DISC	J4806-025	* 1	J4806-025	* 1
5	VALVE SPACER	J4806-014	1	J4806-014	1
6	DIAPHRAGM SPACER	J4806-018	1	J4806-018	1
7	MAIN DIAPHRAGM	J4806-011	* 1	J4806-011	* 1
8	SCREW	JSA520TPTM	6	JSA520TPTM	6
	SCREW (PRE MAY 2012)	JSA520XPTZ	6	JSA520XPTZ	6
9	NAMEPLATE	J8112-124	1	J8112-124	1
10	TOP COVER	J4806-103+	1	J4806-103+	1
11	TOP SPRING HOLDER (Course thread)	J4806-098	1	J4806-098	1
12	TOP CAP	J4806-099	1	J4806-099	1
13	LOCKING LEVER	J4806-105	1	J4806-105	1
14	"O" RING SEAL	JO200032-4475	* 1	JO200032-4475	* 1
15	ADJUSTMENT BUSH (Old Design)	J4806-100	1	J4806-100	1
16	"O" RING SEAL	JORM0051-16	* 1	JORM0051-16	* 1
17	LOADING SPRING	SEE TABLE	1	SEE TABLE	1
18	SPRING ADJUSTING SCREW (Course thread)	J4806-097	1	J4806-097	1
19	VALVE SPINDLE	JSA440IPNZ	1	JSA440IPNZ	1
20	TOP DIAPHRAGM PLATE	J4806-003	1	J4806-003	1
21	SCREW	JSA410TPTM	6	JSA410TPTM	6
	SCREW (PRE MAY 2012)	JSA410XPTZ	6	JSA410XPTZ	6
22	SECONDARY DIAPHRAGM	J4806-095	* 1	J4806-095	* 1
	AIR SECONDARY DIAPHRAGM	J4806-084	* 1	J4806-084	* 1
23	IMPULSE TUBE	J4806-120		J4806-120	
	IMPULSE TUBE (PRE MAY 2011)	J4706-072		J4706-072	
24	"O" RING SEAL	JORM0376-24	* 1	JORM0376-24	* 1
27	COUNTER SINK PLUG	JMFP2 06	1	JMFP2 06	1
28	OUTLET ADAPTOR BUSH	J4806-024+	1	J4806-024+	1
29	METER UNION ASSEMBLY	-----	-	-----	-
30	INLET ADAPTOR BUSH	-----	-	-----	-
32	ORIENTATION LABEL	J7806-027	1	J7806-027	1
33	TOP SPRING HOLDER (Fine Thread)	J4806-127	1	J4806-127	1
34	WASHER	J4806-134	* 1	J4806-134	* 1
35	ADJUSTMENT BUSH (New Design)	J4806-100Z01	1	J4806-100Z01	1
36	SPRING ADJUSTING SCREW (Fine Thread)	J4806-128	1	J4806-128	1
37	CIRCLIP	JCIR1500-080Z	1	JCIR1500-080Z	1
38	SEALING WASHER	J7706A-044	1	J7706A-044	1



Parts List

ITEM	DESCRIPTION	1¼"	No. Off	1½"	No. Off	2"	No. Off
1	BOTTOM PLUG	J4808-017Z03	1	J4808-017Z03	1	J4809-017Z03	1
2	BODY	J4807-011+	1	J4808-084+	1	J4809-071+	1
3	VALVE DISC HOLDER	J4808-015	1	J4808-015	1	J4809-015	1
4	VALVE DISC	J4808-035	* 1	J4808-035	* 1	J4809-027	* 1
5	VALVE SPACER	J4808-014	1	J4808-014	1	J4809-014	1
6	DIAPHRAGM SPACER	J4808-021	1	J4808-021	1	J4809-018	1
7	MAIN DIAPHRAGM	J4808-011	* 1	J4808-011	* 1	J4809-011	* 1
8	SCREW	JSA520TPTM	8	JSA520TPTM	8	JSA520TPTM	8
	SCREW (PRE MAY 2012)	JSA520XPTZ	8	JSA520XPTZ	8	JSA520XPTZ	8
9	NAMEPLATE	J8112-124	1	J8112-124	1	J8112-124	1
10	TOP COVER	J4808-078+	1	J4808-078+	1	J4809-067+	1
11	TOP SPRING HOLDER <i>(Course)</i>	J4806-098	1	J4806-098	1	J4806-098	1
12	TOP CAP	J4806-099	1	J4806-099	1	J4806-099	1
13	LOCKING LEVER	J4806-105	1	J4806-105	1	J4806-105	1
14	"O" RING SEAL	JO200032-4475	* 1	JO200032-4475	* 1	JO200032-4475	* 1
15	ADJUSTMENT BUSH <i>(Old Design)</i>	J4806-100	1	J4806-100	1	J4806-100	1
16	"O" RING SEAL	JORM0051-16	* 1	JORM0051-16	* 1	JORM0051-16	* 1
17	LOADING SPRING	SEE TABLE	1	SEE TABLE	1	SEE TABLE	1
18	SPRING ADJUSTING SCREW <i>(Course)</i>	J4806-097	1	J4806-097	1	J4806-097	1
19	VALVE SPINDLE	JBA650HEXZG	1	JBA650HEXZG	1	JBA865HEXZG	1
20	TOP DIAPHRAGM PLATE	J4808-003	1	J4808-003	1	J4809-003	1
21	SCREW	JSA510TPTM	6	JSA510TPTM	6	JSA510TPTM	8
	SCREW (PRE MAY 2012)	JSA510XPTZ	6	JSA510XPTZ	6	JSA510XPTZ	8
22	SECONDARY DIAPHRAGM	J4808-070	* 1	J4808-070	* 1	J4809-070	* 1
	AIR SECONDARY DIAPHRAGM	J4808-074	* 1	J4808-074	* 1	J4809-064	* 1
23	IMPULSE TUBE	J4808-085	1	J4808-085	1	J4809-074	1
	IMPULSE TUBE (PRE MAY 2011)	J4808-076	1	J4808-076	1	J4709-060	1
24	"O" RING SEAL	JORM0546-24	* 1	JORM0546-24	* 1	JORM0745-30	* 1
27	COUNTER SINK PLUG	JMFP2 07	1	JMFP2 08	1	JMFP2 09	1
28	OUTLET ADAPTOR BUSH	J4807-003+	1	J4807-003+	1	J4809-022+	1
29	METER UNION ASEMBLY	JMU020LJ48	-	JMU050LJ48	-	JMU100LJ48	-
30	INLET ADAPTOR BUSH	J4707-003	1	J4707-003	1	J4709-044	1
32	ORIENTATION LABEL	J7806-027	1	J7806-027	1	J7806-027	1
33	TOP SPRING HOLDER <i>(Fine)</i>	J4806-127	1	J4806-127	1	J4806-127	1
34	WASHER	J4806-134	* 1	J4806-134	* 1	J4806-134	* 1
35	ADJUSTMENT BUSH <i>(New Design)</i>	J4806100Z01	1	J4806100Z01	1	J4806-100Z01	1
36	SPRING ADJUSTING SCREW <i>(Fine)</i>	J4806-128	1	J4806-128	1	J4806-128	1
37	CIRCLIP	JCIR1500-080Z	1	JCIR1500-080Z	1	JCIR1500-080Z	1
38	SEALING WASHER	J7706A-044	-	J7706A-044	-	J7706A-044	-

Note: Part numbers marked + require connection thread to be specified with order.



Spares & Loading Springs

SPARES KITS

Spares kit contents are marked * on parts list

SPARES KIT CODE	SIZE
SK4806-01	3/4" – 1"
SK4808-01	1 1/4" – 1 1/2"
SK4809-01	2"

SPRINGS FOR J48 (3/4", 1", 1 1/4", 1 1/2" & 2") From June 2014
(J48 Regulator, Angled Regulator and Meter Union Regulator)

SPRING RANGE		PART NUMBER AND COLOUR CODE		
"wg	mbar	3/4" & 1"	1 1/4" – 1 1/2"	2"
2 – 6	5 – 15	J4806-146 Dark Green/Lt Blue	J4808-102 Black / Light Blue	J4809-081 White / Brown
5 – 10	12.5 – 25	J4806-004 Black	J4808-103 Black / Lt Green	J4809-082 White / Dark Blue
9 – 14	22.5 – 35	J4806-147 Dark Green / Brown	J4808-104 Silver / Orange	J4809-083 White / Dark Green
12 – 20	30 – 50	J4806-148 Dark Green / Orange	J4808-105 Black / Brown	J4809-084 White / Red
18 – 26	45 – 65	J4808-103 Black / Lt Green	J4808-031 Red / Gold	J4809-085 White / Orange
24 – 32	60 – 80	J4808-008 Red / Orange	J4808-106 Black / Orange	J4809-025 Dark Blue - Grey
30 – 40	75 – 100	J4806-079 Pink / Gold	J4808-075 Pink / Silver	J4809-065 Grey / Gold
40 – 64	100 – 160	J4808-077 Yellow / Orange	J4809-065 Grey / Gold	

SPRINGS FOR J48 (3/4", 1", 1 1/4", 1 1/2" & 2") Up to June 2014
(J48 Regulator, Angled Regulator and Meter Union Regulator)

SPRING RANGE		PART NUMBER AND COLOUR CODE		
"wg	mbar	3/4" & 1"	1 1/4" – 1 1/2"	2"
2 – 6	5 – 15	J4806-007 Yellow	J4808-004 Red / Yellow	J4809-007 Dark Blue / Yellow
5 – 10	12.5 – 25	J4806-004 Black	J4808-007 Red / Black	J4809-004 Dark Blue / Black
9 – 14	22.5 – 35	J4806-005 Orange	J4808-008 Red / Orange	J4809-005 Dark Blue / Orange
10 – 30	25 – 75	J4806-101 Yellow / Black	J4808-077 Yellow / Orange	J4809-066 Yellow / Dark Green
28 – 40	70 – 100	J4806-079 Pink / Gold	J4808-075 Pink / Silver	J4809-065 Grey / Gold
36 – 64	90 – 160	J4808-077 Yellow / Orange	J4809-065 Grey / Gold	



Maintenance Instructions

Maintenance Instructions for: J48 MKII Regulator 3/4" - 2",
J48 MKII Angled Regulator 3/4" - 2", J48 MKII Meter Union Regulator

Dismantling Procedure:

1. Pull off top cap (12).
2. Turn spring adjusting screw (36) anti-clockwise (to reduce loading on spring).
3. Carefully lift protruding end of locking lever (13) just above adjusting bush (35) whilst in this position turn (octagon shaped) adjusting bush (35) assembly anti-clockwise until disengaged. The adjusting bush (35) can then be removed from the top cover (10).
4. Remove the loading spring (17) from the top cover (10).
NOTE: If adjusting bush assembly is to be dismantled for "o" ring replacement, follow procedure. If to be left assembled proceed to instruction number 9.
5. Lift keyhole end of locking lever (13) over sloping peg in adjusting bush (35), and slide forward until, disengaged from spring adjusting screw (36) and remove.
6. Pull spring adjusting screw (36) from adjusting bush (35).
7. Remove "O" rings (16) & (14) from spring adjusting screw (36) and adjusting bush (35) respectively.
8. Lift washer (34) from spring adjusting screw (36) and remove.
9. Remove top cover screws (8) then carefully remove the top cover (10).
- 10.1 For J48 Regulator: Unscrew bottom plug (1) and remove from body (2).
- 10.2 For J48 Angled Regulator: Unscrew outlet adaptor bush (28) and remove from body (2).
- 10.3 For J48 Meter Union Regulator: Unscrew meter union assembly (29) and remove from body (2).
11. Remove "O" ring (24) from (1), (28) or (29).
12. Restrain valve disc holder (3) with suitable box spanner and unscrew the valve spindle (19).
13. Withdraw the valve disc holder (3), valve disc (4) and valve spacer (5) through the bottom plug opening.
14. Remove the valve spindle (19).
15. Remove the top diaphragm plate (20).
16. Carefully remove main diaphragm (7).
17. Remove diaphragm spacer (6).
18. Remove secondary diaphragm screws (21).
19. Carefully remove the secondary diaphragm (22).
20. Check hole in impulse tube (23) is clear. DO NOT REMOVE FROM BODY.
21. Wipe valve seat and body clean of any dirt particles, taking care not to damage sealing surface in body.
22. Inspect all diaphragms and soft seals and replace where necessary (a spares kit is available for this purpose).
23. For J48 Angled Regulator and J48 Meter Union Regulator do not remove counter sunk plug (27) unless required.
24. For J48 Meter Union Regulator, Do not remove inlet adaptor bush (30), unless required. Note: in some instances an inlet filter may be incorporated into this bush. Remove filter and clean.



Maintenance Instructions

Rebuilding procedure:

The use of Molykote 111 "O" ring lubricant is recommended during the rebuild- unless for use with oxygen when no lubricant should be used.

1. Locate secondary diaphragm (22) with convolution uppermost on to the body (2). Ensure screw holes and impulse tube holes are aligned correctly.
2. Secure secondary diaphragm (22) in position using screws (21).
3. Place diaphragm spacer (6) on secondary diaphragm (22) ensuring diaphragm bead is located correctly in the groove.
4. Place main diaphragm (7) with convolution uppermost, ensuring that the bead is located in the groove in the body (2).
5. Locate the top diaphragm plate (20) ensuring raised edge is uppermost.
6. Insert the valve spindle (19) through the centre hole in top diaphragm plate (20), main diaphragm (7) and diaphragm spacer (6).
7. Locate valve spacer (5) on to valve spindle (19) through bottom plug opening.
8. Assemble valve disc (4) on to valve disc holder (3) with bead uppermost.
9. Screw valve disc holder (3) complete with valve disc (4) on to threaded end of valve spindle (19) through bottom plug opening. DO NOT TIGHTEN.
10. Restrain valve disc holder (3) with suitable box spanner and tighten valve spindle (19).
11. Place "O" ring seal (24) into "O" ring seal groove in bottom plug (1), outlet adaptor bush (28) or meter union assembly (29).
12. Replace the component (1), (28) or (29) complete with "O" ring over centre shaft of valve disc holder (3) into body (2) and screw tightly in position.
13. Carefully replace top cover (10) on to body (2) with vent facing the outlet and secure with top cover screws (8).
14. Insert loading spring (17) over spring location ridge in top diaphragm plate (20).
NOTE: If adjusting bush assembly (35) has been dismantled follow procedure, if it has been left assembled then proceed to instruction number 21.
15. Slide "O" ring seal (16) over slotted end of spring adjusting screw (36) into second groove. (i.e. groove nearest thread).
16. Replace washer (34) over slotted end of spring adjusting screw (36) and slide down until it sits on shoulder of adjusting screw.
17. Slide "O" ring seal (14) into "O" ring groove on adjusting bush (35).
18. Push spring adjusting screw (36) into hole in the bottom of the adjusting bush (35) until parts are firmly together.
19. Position key hole slot in locking lever (13) over slotted end of spring adjusting screw (35) and slide over slopping peg in adjusting bush (35) until firmly locked in position.
20. Screw top spring holder (33) anti-clockwise to within 10mm of underside of adjusting bush (35).
21. Position underside of top spring holder (33) on to loading spring (17).
22. Align slots in top spring holder (33) with splines in top cover (10) and push adjusting bush (35) assembly into top cover (10) as far as possible.
23. Turn adjusting bush assembly (35) clockwise until locking lever (13) snaps into any of the three locking castellations in top cover (10).
24. Set units to required pressure.
25. Replace top cap (12) by aligning slot in cap with sealing wire lug and push over until it clicks into position, and seal if necessary.