



Elster Jeavons S100 Slam Shut Valve



For
S100 Slam Shut Valve 50mm, 80mm and 100mm Sizes

MS1002EN | 07/01/17



Index

Commissioning Instructions	3
General Arrangement	5
Parts List	8
Spring Tables	13
Maintenance Instructions	14



Commissioning Instructions

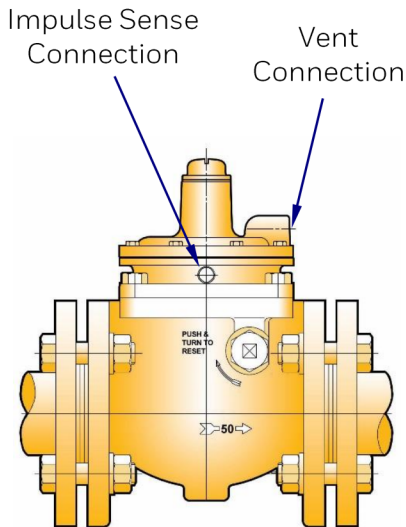

Fig. 1

FITTING REGULATOR INTO PIPEWORK INSTALLATION INSTRUCTIONS (Fig 1)

1. The unit should not be installed in a corrosive environment.
2. The ambient temperature (surface temperature) should be within the limits stated on the slam shut valve catalogue.
3. Check the maximum allowable pressure on the slam shut valve nameplate against the installation specification. Remove protective discs from flanges on inlet and outlet ports.
4. Ensure installation pipework is thoroughly clean.
5. The direction of gas flow must be the same as the arrows on the slam shut body.
6. Install the slam shut valve into the pipework, using gaskets and bolting approved to National Standards.
7. Connect impulse line to sense chamber tapping, using jointing compound approved to National Standards.
8. Vent line can be installed as below if required: Remove vent protective screen and connect vent pipe line to top cover, using jointing compound approved to National Standards.
9. Lead pipe to atmosphere in accordance with National Standards.
10. Ensure no water can penetrate pipe termination point.

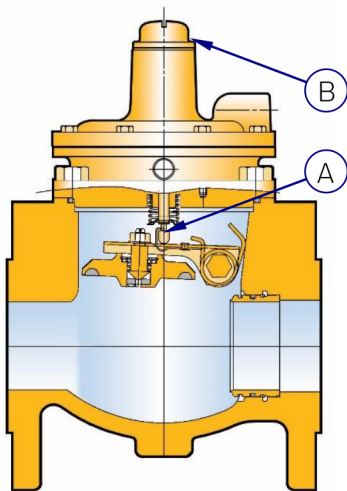

Fig. 2

VALVE OPERATION (Fig 2).

As the sense pressure rises to the desired trip point, it acts against the pressure sensing diaphragm and pressure setting spring.

A bearing cage is lifted, allowing ball bearings to move radially outwards against the bearing cage taper, to a point where the shoulder diameter on the spring loaded shaft, is free to pass through the bearings (TRIP POINT).

As the shaft moves through the bearings, it releases the spring clip (A) thereby allowing the valve seat assembly to operate in the closed position.

A valve position indicator (B) indicates that the valve has moved to the closed position.



Commissioning Instructions

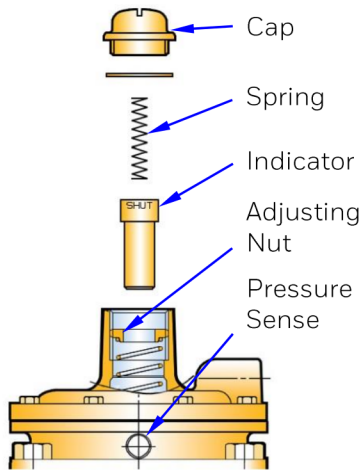

Fig. 3

SETTING THE TRIP PRESSURE (Fig 3)

5. Ensure valve is depressurized.
6. Remove cap, spring and indicator.
7. Screw adjusting nut clockwise as far as it will go, Do Not Force.
8. Induce desired set pressure at pressure sense point.
9. Wind out (anti-clockwise) adjusting nut half a turn at a time until valve trips.
10. Remove pressure, reset valve (see below).
11. Slowly induce pressure at sense point, and check that valve trips at desired pressure. Adjust as necessary.
12. Valve is now set.
13. Refit indicator, spring and cap.

NOTE; if correct trip pressure is not obtainable, choose correct spring from tables on page 13, and go back to instruction 3 above.

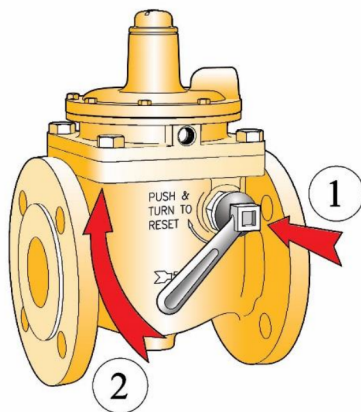

Fig. 4

RE-ARMING THE VALVE (Fig 4)

Re-arming of the valve is carried out manually. Prior to re-arming, the cause of operation should first be ascertained and rectified. The valve must be isolated and downstream pressure vented. In order to operate the correct procedure must be followed

The reset shaft requires to be pushed and rotated (1) until it is felt to engage the latching assembly. Further rotation using light pressure causes the automatic equalizing valve to operate.

Do not attempt to force the valve open. Once pressure has equalized the valve seat assembly will be felt to lift from the seat allowing the reset shaft to be easily rotated (2) to the latching position.

When the valve is satisfactorily re-armed the valve position indicator will move from the window ((B) Fig 2).



General Arrangement

SLAM SHUT ASSEMBLY Fig. 5

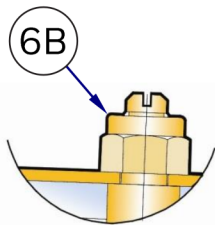
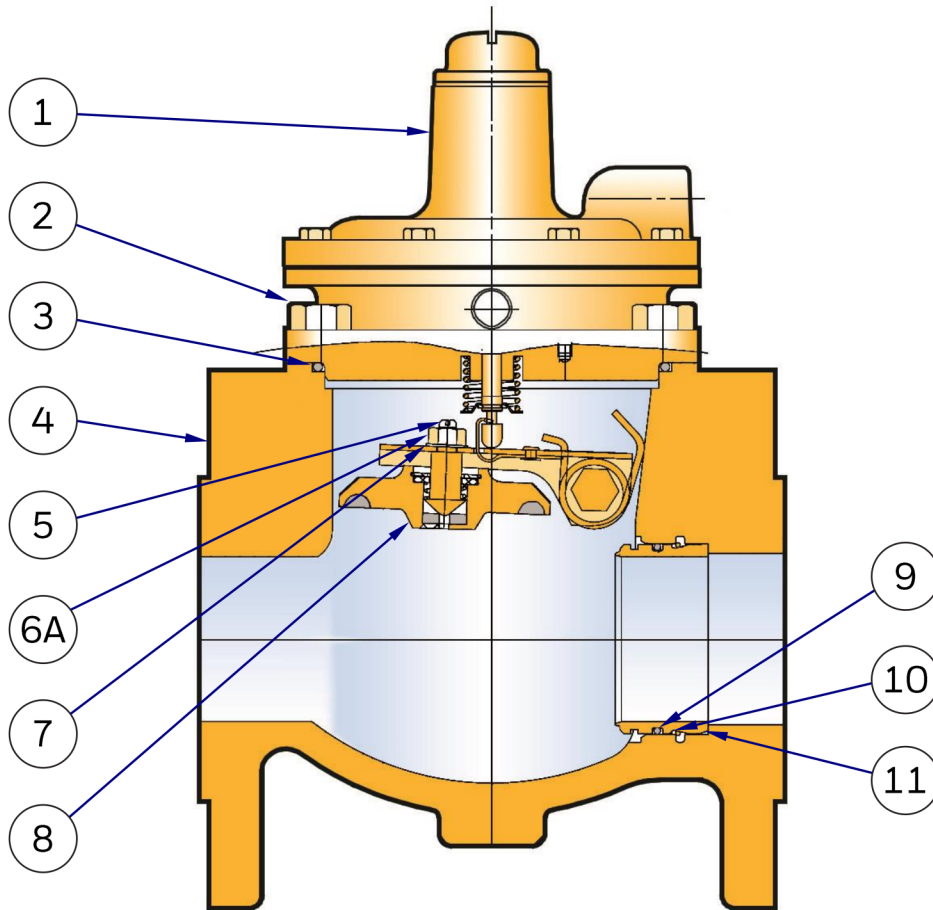

ALTERNATIVE VERSION
(Washer Item 7 Not Required)

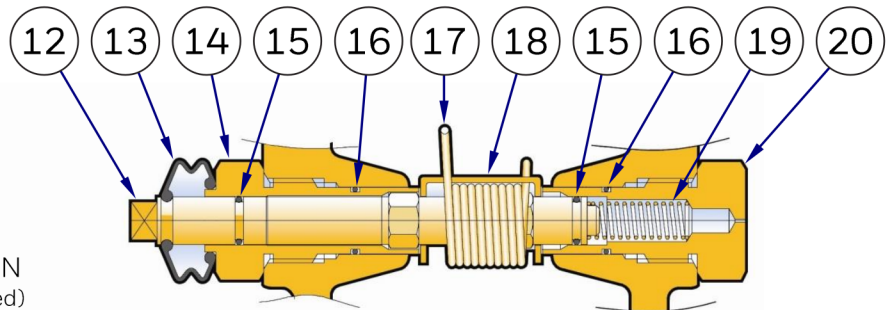

SECTION A-A Fig. 6



General Arrangement

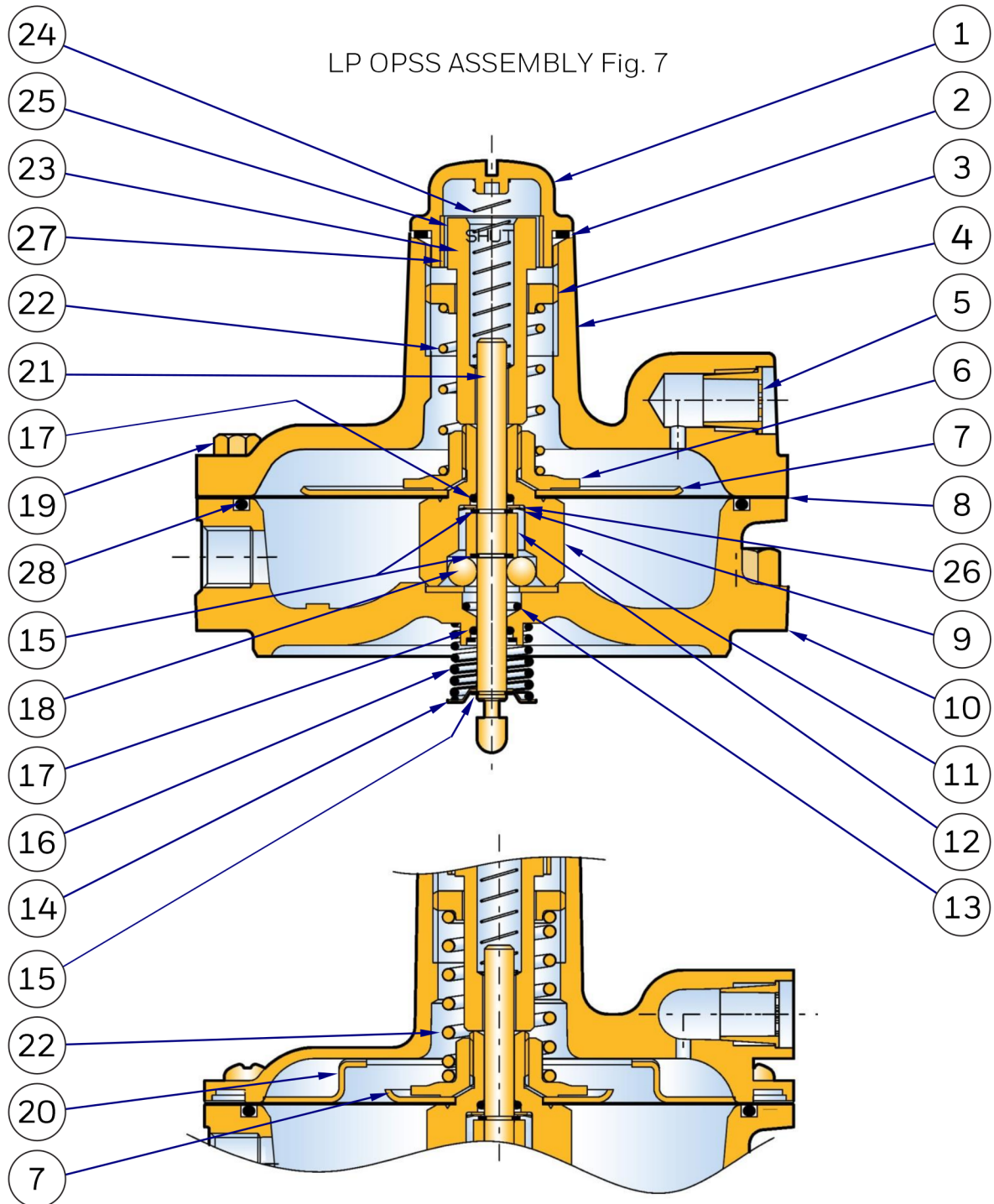



General Arrangement

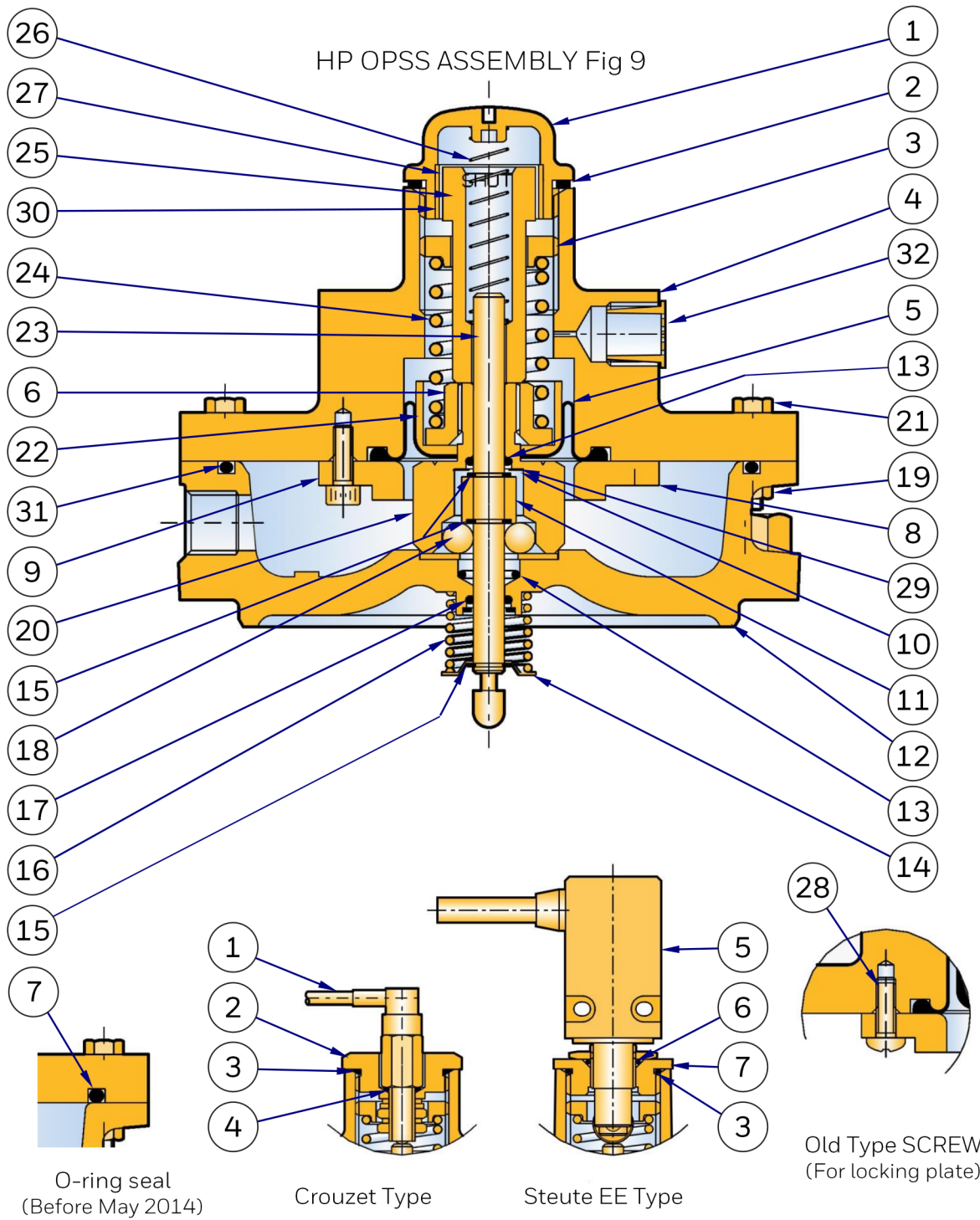

MICRO SWITCH ASSEMBLIES Fig 10
(For LP, MP & HP Assemblies)



Parts List 1

FOR SLAM SHUT ASSEMBLY AND SECTION "A-A", SEE FIGS 5 & 6

ITEM	DESCRIPTION	PART NUMBER	No. Off	Size (mm)	
1	OPSS ASSEMBLY LP	S1HL09	1	50,80	
	OPSS ASSEMBLY LP	S1HL12	1	100	
	OPSS ASSEMBLY MP	S1HM09	1	50,80	
	OPSS ASSEMBLY MP	S1HM12	1	100	
	OPSS ASSEMBLY HP	S1HH09	1	50,80	
	OPSS ASSEMBLY HP	S1HH12	1	100	
2	SCREW	O3512242	4	50,80,100	
3	"O" RING	JOBS243	* 1	50,80	
	"O" RING	JOBS247	* 1	100	
4	BODY ASME 150 RAISED FACE	J10009-040I01	1	50	
	BODY ASME 150 FLAT FACE	J10009-040I02	1	50	
	BODY NP16	J10009-017C01	1	50	
	BODY NP25	J10009-017T01	1	50	
	BODY ASME 150 RAISED FACE	J10011-001I01	1	80	
	BODY ASME 150 FLAT FACE	J10011-001I02	1	80	
	BODY NP16	J10011-001C01	1	80	
	BODY NP25	J10011-001T01	1	80	
	BODY ANSI 150 RAISED FACE	J10012-001I01	1	100	
	BODY ANSI 150 FLAT FACE	J10012-001I02	1	100	
	BODY NP16	J10012-001C01	1	100	
	BODY NP25	J10012-001T01	1	100	
	5	STEM (Included in Item 8)			
	6A	NUT (Normal Nut)	JNA6FSD	1	50,80,100
6B	NUT (Lock Nut)	JNA6PZ	1	50,80,100	
7	WASHER	JWM6ETLS	1	50,80,100	
8	VALVE DISC ASSEMBLY	S1VC09	* 1	50	
	VALVE DISC ASSEMBLY	S1VC11	* 1	80	
	VALVE DISC ASSEMBLY	S1VC12	* 1	100	



Parts List 1 - Continued

FOR SLAM SHUT ASSEMBLY AND SECTION "A-A", SEE FIGS 5 & 6

ITEM	DESCRIPTION	PART NUMBER	No. Off	Size (mm)
9	"O" RING	JOBS138	* 1	50
	"O" RING	JO200152-4475	* 1	80
	"O" RING	JOBS243	* 1	100
10	RING RETAINER	J10009-031	1	50
	RING RETAINER	J10011-004	1	80
	RING RETAINER	J10012-004	1	100
11	SEAT RING	J10009-010	1	50
	SEAT RING	J10011-002	1	80
	SEAT RING	J10012-002	1	100
12	SHAFT	J10009-028	1	50,80,100
13	GAITER V6-438	I544199	1	50,80,100
14	RESET SHAFT BUSH	J10009-029	1	50,80,100
15	"O" RING	JOBS012	* 2	50,80,100
16	"O" RING	JOBS015	* 2	50,80,100
17	SPRING CLOSING	J10009-030 (up to May 2010)	1	50
	SPRING CLOSING	J10011-005	1	50, 80
	SPRING CLOSING	J10012-005	1	100
18	LEVER ASSEMBLY	S1LC09	1	50
	LEVER ASSEMBLY	S1LC11	1	80
	LEVER ASSEMBLY	S1LC12	1	100
19	SPRING	J10009-005	1	50,80,100
20	SPRING RESET SHAFT BUSH	J10009-023	1	50,80,100

NOTE: Items marked * in parts lists are contained in spares kits.



Parts List 2

FOR LOW/MEDIUM PRESSURE OPSS ASSEMBLIES, SEE FIGS 7 & 8

ITEM	DESCRIPTION	PART NUMBER	No. Off	Size (mm)
1	PLUG SEAL	I544127	1	50,80,100
2	GASKET (PLUG SEAL)	J10009-006	* 1	50,80,100
3	SCREW ADJUSTMENT	I513121	1	50,80,100
4	TOP COVER (1/4NPT)	I513125 (up to July 2006)	1	50,80,100
	TOP COVER (Rc1/4)	J10009-072A01 (Aug 2006 to July	1	50,80,100
	TOP COVER (Rp1/4)	J10009-072B01 (Aug 2006 to July	1	50,80,100
	TOP COVER (Rc1/4)	J10009-079A01 (after August 2014)	1	50,80,100
	TOP COVER (Rp1/4)	J10009-079B01 (after August 2014)	1	50,80,100
5	SCREEN VENT	J12506-277	1	50,80,100
6	NUT (DIAPHRAGM)	J10009-035Z01	1	50,80,100
7	DIAPHRAGM PLATE LP	I513108	1	50,80,100
	DIAPHRAGM PLATE MP	I513101	1	50,80,100
8	DIAPHRAGM	I513112	* 1	50,80,100
9	WASHER STARLOCK	JCIR1305-056Z	* 1	50,80,100
10	ADAPTOR BODY Rc1/4	J10009-009A01	1	50,80
	ADAPTOR BODY 1/4" NPT	J10009-009F01	1	50,80
	ADAPTOR BODY Rp1/4	J10009-009B01	1	50,80
	ADAPTOR BODY Rc1/4	J10009-009A02	1	100
	ADAPTOR BODY 1/4" NPT	J10009-009F02	1	100
	ADAPTOR BODY Rp1/4	J10009-009B02	1	100
11	BALL CAGE	J10009-021	1	50,80,100
12	COLLAR	J10009-022	1	50,80,100
13	"O" RING	JOBS012	* 1	50,80,100
14	RETAINER	I544145	1	50,80,100
15	RING	JCIR1800-025B	3	50,80,100
16	SPRING (SHUT-OFF)	J10009-004	1	50,80,100
17	"O" RING	03110370	* 2	50,80,100
18	BALL (1/4 DIA)	JBALL1/4	6	50,80,100
19	SCREW (BODY)	JSA512XPTZ (used with cover I513125)	8	50,80,100
	SCREW (BODY)	03512149 (used with cover J10009-072 &	8	50,80,100
20	REDUCING RING MP	I513102	1	50,80,100
21	SHAFT	J10009-027	1	50,80,100
22	LOADING SPRINGS LP/MP	SEE TABLE	1	50,80,100
23	POSITION INDICATOR	J10009-026	1	50,80,100
24	SPRING (INDICATOR)	J10009-002	1	50,80,100
25	DECAL POSITION INDICATOR	J10009-025	1	50,80,100
26	O-RING RETAINING WASHER	J10009-075	1	50,80,100
27	MASKING INDICATOR SLEEVE	J10009-024	1	50,80,100
28	"O" RING	03109655	* 1	50,80,100

NOTE: Items marked * in parts lists are contained in spares kits.



Parts List 3

FOR HIGH PRESSURE OPSS ASSEMBLIES, SEE FIG. 9

ITEM	DESCRIPTION	PART NUMBER	No. Off	Size (mm)
1	PLUG SEAL	I544127	1	50,80,100
2	GASKET (PLUG SEAL)	J10009-006	* 1	50,80,100
3	SCREW ADJUSTMENT	I513121	1	50,80,100
4	TOP COVER	J10009-032	1	50,80,100
5	DIAPHRAGM	J10009-038	* 1	50,80,100
6	NUT (DIAPHRAGM)	J10009-039	1	50,80,100
7	"O" RING (BEFORE MAY 2014)	JOBS243	* 1	50,80,100
8	LOCKING PLATE	J10009-034	1	50,80,100
9	SCREW (LOCKING PLATE)	JSA412SANZI	4	50,80,100
10	WASHER STARLOCK	JCIR1305-056Z	* 1	50,80,100
11	COLLAR	J10009-022	1	50,80,100
12	ADAPTOR BODY Rc1/4	J10009-009A01	1	50,80
	ADAPTOR BODY 1/4" NPT	J10009-009F01	1	50,80
	ADAPTOR BODY Rp1/4	J10009-009B01	1	50,80
	ADAPTOR BODY Rc1/4	J10009-009A02	1	100
	ADAPTOR BODY 1/4" NPT	J10009-009F02	1	100
	ADAPTOR BODY Rp1/4	J10009-009B02	1	100
13	"O" RING	O3110370	* 2	50,80,100
14	RETAINER	I544145	1	50,80,100
15	RING	JCIR1800-025B	3	50,80,100
16	SPRING (SHUT-OFF)	J10009-004	1	50,80,100
17	"O" RING	JOBS012	* 1	50,80,100
18	BALL (1/4 DIA)	JBALL1/4	6	50,80,100
19	NUT (BODY)	O3580175	8	50,80,100
20	BALL CAGE	J10009-036	1	50,80,100
21	SCREW (BODY)	JSA420HHNZG (up to July 2007)	8	50,80,100
	SCREW (BODY)	JSA420HHNZG (after Aug 2007)	4	50,80,100
	SCREW (BODY)	JSA425HHNZG (after Aug 2007)	4	50,80,100
22	DIAPHRAGM CUP	J10009-033	1	50,80,100
23	SHAFT	J10009-027	1	50,80,100
24	LOADING SPRINGS HP	SEE TABLE	1	50,80,100
25	POSITION INDICATOR	J10009-026	1	50,80,100
26	SPRING	J10009-002	1	50,80,100
27	DECAL POSITION INDICATOR	J10009-025	1	50,80,100
28	Old Type SCREW (LOCKING PLATE)	JSA410XPNZ	4	50,80,100
29	O-RING RETAINING WASHER	J10009-075	1	50,80,100
30	MASKING INDICATOR SLEEVE	J10009-024	1	50,80,100
31	"O" RING	O3109655	* 1	50,80,100
32	SCREEN VENT	J12506-277	1	50,80,100

NOTE: Items marked * in parts lists are contained in spares kits.



Parts List 4

FOR MICRO SWITCH ASSEMBLY, SEE FIG. 10

ITEM	DESCRIPTION	PART NUMBER	No. Off	Size (mm)
1	MICRO SWITCH (CROUZET)	JMS02	1	50,80,100
2	TOP CAP (CROUZET)	J10009-037	1	50,80,100
3	"O" RING (BOTH)	JOBS120	1	50,80,100
4	"O" RING (CROUZET)	03110340	1	50,80,100
5	MICRO SWITCH (STEUTE)	JMS03	1	50,80,100
6	"O" RING (STEUTE)	JOBS015	1	50,80,100
7	TOP CAP (STEUTE)	J10009-076	1	50,80,100

Micro Switch Kit

DESCRIPTION	PART No.
STEUTE MICRO SWITCH KIT (FITS ALL TYPES AND SIZES)	S1MS02

Spares Kits

DESCRIPTION	PART No.
50mm LOW / MEDIUM PRESSURE	SK109-01
50mm HIGH PRESSURE	SK109-02
80mm LOW / MEDIUM PRESSURE	SK111-01
80mm HIGH PRESSURE	SK111-02
100mm LOW / MEDIUM PRESSURE	SK112-01
100mm HIGH PRESSURE	SK112-02



Spring Tables

All Sizes

LOW PRESSURE

mbar	"wg / PSIG	PART No.	COLOUR CODE
18 - 35	7 - 14" wg	J10009-011	-
36 - 70	14 - 28" wg	J10009-012	LIGHT BLUE
71 - 140	1 - 2 PSI	J10009-013	RED BROWN
141 - 200	2 - 3 PSI	J10009-014	PURPLE
201 - 350	3 - 5 PSI	J10009-015	ORANGE / YELLOW
351 - 560	5 - 8 PSI	J10009-016	ORANGE / DARK GREEN

Low pressure units use Diaphragm Plate Part No. I513108

All Sizes

MEDIUM PRESSURE

mbar	PSIG	PART No.	COLOUR CODE
561 - 975	8 - 14	J10009-015	ORANGE / YELLOW
976 - 1400	14 - 20	J10009-016	ORANGE / DARK GREEN

For medium pressure replace LP Diaphragm plate Part No. I513108, with MP Diaphragm plate Part No. I513101, and add MP Reducing ring Part No. I513102.

All Sizes

HIGH PRESSURE

bar	PSIG	PART No.	COLOUR CODE
1 - 1.8	14 - 26	J10009-014	PURPLE
1.7 - 3.5	24 - 51	J10009-015	ORANGE / YELLOW
2.5 - 6	36 - 87	J10009-016	ORANGE / DARK GREEN



Maintenance Instructions - Slam Shut Assembly

Drawing Reference: Figs. 5 & 6
Parts List Reference: Parts List 1

NOTE: Numbers in brackets identify items on drawings

Regulator Dismantling Procedure.

Removal of OPSS assembly from Slam-Shut Body:

1. Check external surfaces for excessive corrosion.
2. Ensure all valves are closed, and line is fully vented to the atmosphere.
3. Remove impulse line to OPSS assembly (1) and mark position of OPSS assembly relative to slam-shut body (4).
4. Remove 4 screws (2) holding OPSS assembly (1) to the slam-shut body (4). If the slam-shut is closed, the OPSS assembly can be lifted out vertically. If the slam-shut is open, then raise OPSS assembly at outlet side and slide towards outlet, this will release the latch closing the slam shut and allow the OPSS assembly to be lifted clear of the slam shut body.

Dismantling of Slam-Shut Body:

1. Remove "O" ring (3) from slam-shut body (4).
2. Carefully using pliers, disengage closing spring (17) by pulling tail of spring into locking slot on lever assembly (18). Valve disc assembly (8) and lever assembly (18) will now be free to swing, without resistance from closing spring (17).
3. Remove gaiter (13) from shaft (12), then unscrew reset bush (14) from slam-shut body (4).
4. Whilst holding valve disc assembly (8) with lever assembly (18) withdraw shaft (12) from slam-shut body (4). (A slight rotation may be required to remove shaft from lever assembly).
5. The valve disc assembly (8) with lever assembly (18) can now be lifted clear of the slam-shut body (4).

WARNING: Do not disengage spring (17) from the slot in the lever assembly (18).

6. Unscrew reset bush (20) from slam shut body (4), remove spring (19) from inside reset bush (20).
7. The face of seat ring (11) can now be inspected for evidence of damage.
8. If seat ring (11) is damaged remove as follows:
Place a screwdriver in seat ring slot, and using the screwdriver as a lever, slide seat ring towards inlet, repositioning screwdriver as far round both sides of seat ring as possible, to ensure seat ring (11) slides out square to slam-shut body (4). (Note: seat ring (11) is a push fit into slam-shut body (4), and is held in place by a seat ring retainer (10) and is sealed by "O" ring (9).
9. "O" ring (9) and seat ring retainer (10) can now be removed from slam-shut body (4).
10. Unscrew valve stem nut (6A) or (6B) (whilst using screwdriver to prevent valve stem (5) from rotating), Remove washer (7) if fitted from under valve stem nut (6). Valve disc assembly (8) can now be removed from lever assembly (18).
11. Remove "O" rings (15) and (16) from shaft (12) and bushes (14) and (20).
Discard all "O" rings, valve disc assembly (8) and replace with new parts from spares kit.
To maintain OPSS see separate instructions later.



Maintenance Instructions - Slam Shut Assembly

Rebuilding Procedure for Slam-Shut Assembly.

Rebuilding of slam-shut body:

The use of Dow Corning Molycote 55M "O" ring lubricant is recommended during the rebuild- unless for use with oxygen when no lubricant should be used.

1. Replace seat retaining ring (10) into slot in slam-shut body (4).
2. Refit "O" ring (9) onto seat ring (11) middle groove and lightly lubricate with silicon grease.
3. Fit seat ring (11) into slam-shut body (4) with the chamfer on the inside of the seat ring (11) to be facing inwards. Care should be taken not to damage seating face.
4. If removed fit closing spring (17) into lever assembly (18), (using pliers) the short leg of the spring fits into the hole in the lever assembly, the long leg of the spring fits into the slot in the lever assembly.

NOTE: The reset shaft assembly is universal handed, and can be refitted from either side of the slam shut valve.

5. Attach the seat disc assembly (8) to the lever assembly (18) by fitting stem (5) of valve disc assembly through hole in lever assembly (18), and securing in position using washer (7) if fitted and nut (6A) or (6B). If self locking nut (6B) is used, do not fit washer (7).
6. Fit "O" ring (16) into groove in reset shaft bush (14).
7. Fit "O" ring (16) into groove in spring reset shaft bush (20).
8. Place spring (19) into spring reset shaft bush (20) then screw reset shaft into slam-shut body (4). On the opposite side to re-cocking.
9. Refit 2 "O" rings (15) into grooves in shaft (12), lightly lubricate shaft and "O" rings.
10. Holding seat disc assembly (8) with lever assembly (18) in slam-shut body (4), insert shaft (12) through lever assembly, so that spigot on the end of the shaft locates into the spring (19), which is held in the slam-shut body by the reset shaft bush (20). (A slight rotation of the shaft (12) may be required to ensure the hexagon section of the shaft passes through the lever assembly).
11. Whilst pushing the shaft (12) in to the slam-shut body (4), place the reset shaft bush (14) over the end of shaft (12), and screw into the slam-shut body (4).
12. Refit shaft cover (13) onto shaft (12).
13. Check that valve disc assembly (8) with lever assembly (18) is free to swing.
14. CAREFULLY (using pliers) release spring tail out of slot in the lever assembly (18) (see label on lever assembly for direction to release spring).
15. Using a 9/16" Spanner or reset tool on reset shaft (12), check the operation of assembly by pressing shaft towards the slam-shut body (4), and rotating clockwise. A slight rotation may be required to locate shaft hexagon in lever assembly. Slam-shut should freely open and close when pressure on reset shaft is released.
16. Lightly lubricate "O" ring (3) and fit into groove in slam-shut body (4).
17. Once OPSS assembly (1) has been assembled in TRIPPED position, (see section for OPSS assembly procedure) place OPSS assembly (1) on top of slam-shut body (4). Check (see fig 5) orientation of OPSS assembly (1) to slam-shut body (4). Or replace using alignment marking taken on dismantling.
18. Secure OPSS assembly (1) to slam-shut body (4) using 4 screws (2).
19. Recommission unit as described in commissioning instructions.



Maintenance Instructions - LP / MP OPSS Assemblies

Drawing Reference: Figs. 7, 8 & 10
Parts List Reference: Parts List 2 & 4

NOTE: Numbers in brackets identify items on drawings

Dismantling Procedure for LP/MP OPSS Assemblies.

If Micro Switch is not fitted go to instruction 8.

(Drawing Ref.: Fig 10, Parts List 4.)

For units with Crouzet Micro Switch:

1. Unscrew top cap (2) together with "O" ring (3) from chimney of top cover.
2. Remove "O" ring (3) from seal plug (2).
3. Unscrew nuts and washers from seal plug (2), so micro switch (1) together with "O" ring (4) can be removed from seal plug (2).
4. Carefully remove "O" ring (4) from micro switch (1). Go to instruction 10.

For units with Steute Micro Switch

5. Unscrew top cap (7) together with "O" ring (3) from chimney of top cover.
6. Loosen locknut and unscrew micro switch (5) with "O" ring (6) from chimney of top cover.
7. Carefully remove "O" ring (6) from micro switch (5). Go to instruction 10.

For units without Micro switch

(Drawing Ref.: Figs 7 & 8, Parts List 2.)

8. Unscrew seal plug (1) together with gasket (2) from chimney of top cover (4), and lift out position indicator (23) (with label (25) glued on side), and spring (24).
 9. Remove gasket (2) from seal plug (1).
 10. Turn screw adjustment (3) anti-clockwise and remove, then lift out spring (22).
 11. Make note of the position of the vent in the top cover (4), relative to the horizontal tapped hole in the adaptor body (10).
 12. Remove 8 screws (19) holding top cover (4) onto the adaptor body (10), then lift off top cover (4).
 13. For MP ONLY, remove the reducing ring (20) from the adaptor body (10).
 14. Carefully lift off diaphragm assembly from adaptor body (10), taking care that all 6 balls (18) fall into adaptor body (10).
 15. Remove all 6 balls (18) from adaptor body (10).
 16. Remove "O" ring (28) (for units after May 2014) from groove in adaptor body (10).
 17. Unscrew diaphragm nut (6) from ball cage (11), lift off diaphragm plate (7) and diaphragm (8).
 18. Remove starlock washer (9) and "O" ring (17) from ball cage (11).
 19. Place adaptor body (10) in vice fitted with soft jaws, with shut-off spring (16) uppermost, taking care not to over tighten which could result in damage to the body.
 20. Compress shut-off spring (16) with pliers, pushing down on retainer (14). Using fine pointed pliers remove circlip (15). (as circlip is small, care must be taken so that is not misplaced).
 21. Shut-off spring (16), retainer (14) and shaft (21) can now be removed.
 22. Remove adaptor body (10) from vice, and check that shock absorber "O" ring (13) is either on the shaft (21) or still in the adaptor body (10). Then remove "O" ring (13).
 23. Carefully remove "o" ring (17) from adaptor body (10).
 24. It is not necessary to remove collar (12) from shaft (21) unless damaged. This can be removed by carefully removing circlips (15) and sliding off collar (12) from shaft (21).
- Discard "O" rings and diaphragm (8) and replace with new parts from spares kit.



Maintenance Instructions - LP / MP OPSS Assemblies

Rebuilding Procedure for LP/MP OPSS Assemblies.

The use of Dow Corning Molycote 55M "O" ring lubricant is recommended during the rebuild- unless for use with oxygen when no lubricant should be used.

1. Fit "O" ring (17) into adaptor body (10), taking care not to damage it whilst fitting (use only blunt nose tools if needed).
2. Lightly lubricate shaft (21) with silicon grease, place through adaptor body , Fit shock absorber "O" ring (13) into underside of adaptor body (10),
3. Place adaptor body assembly (10) in vice, fitted with soft jaws, with "O" ring (17) uppermost, taking care not to over tighten which could result in damage to the body, refit spring (16) and retainer (14) over shaft (21).
4. To enable spring (16) to be compressed for refitting of circlips (15), it may be necessary to place packing below the shaft (21) in the vice. Using tool add circlip (15) into the groove nearest round end of shaft (21), (so spring (16) and retainer (14) are held in position).
5. Remove adaptor body assembly (10) from vice, then invert and reclamp in vice. If removed place collar (12) over shaft (21) with counter bore of collar facing adaptor body (10), retain collar (12) in position on shaft (21), by fitting 2 circlips (15) (using tool) into 2 grooves on shaft (21).
6. Fit "O" ring (17) into ball cage (11), retain in position by fitting starlock washer (9) into ball cage (11).
7. Place diaphragm (8) with Reinforcing facing upwards over ball cage (11), add diaphragm plate (7) on top of diaphragm (8).
8. Fasten diaphragm assembly (8) together by threading diaphragm nut (6) over ball cage (11).
9. Apply grease to 6 balls (18), locate balls around collar (12), grease will hold the balls in position.
10. Fit "O" ring (28) (for units after May 2014) into groove in top face of adaptor body (10).
11. Place Diaphragm assembly (8) over shaft (21), ensuring 6 balls are fitted inside ball cage (11), and the 8 holes in diaphragm (8) line up with holes in the adaptor body (10).
12. For MP ONLY Place reducing ring (20) over diaphragm assembly (8).
13. Place top cover (4) onto adaptor body assembly (10), ensure holes in diaphragm (8), adaptor body (10) and cover (4) line up. Clamp top cover (4) onto adaptor body assembly (10), using 8 taptite screws (19).

NOTE: The position of the vent in the top cover (4), relative to the tapped hole in the side of the adaptor body (10) should be as shown in fig 5, or as noted in dismantling instructions.

14. Replace spring (22) in cover (4) over spigot of diaphragm nut (6).
15. Thread adjusting screw (3) into chimney of top cover (4).
16. If removed add screen vent (5) into vent of top cover (4).

If Micro Switch is not fitted go to instruction 19.

(Drawing Ref.: Fig 10, Parts List 4).

For units fitted with Crouzet Micro Switch

17. Add "O" ring (4) onto micro switch (1).
18. Fit "O" ring (3) onto seal plug (2).
19. Place micro switch assembly (1) into recess in centre of seal plug (2), fasten together using nuts and washers.

Go to instruction 25.



Maintenance Instructions - LP / MP OPSS Assemblies

Rebuilding Procedure for LP/MP OPSS Assemblies (Continued).

For units fitted with Steute Micro Switch

20. Add "O" ring (3) onto top cap (7).

21. Push "O" ring (6) over thread of micro switch (5) to underside of locknut.

22. Screw micro switch (5) into top cap (7) and tighten locknut to leave 3mm gap between nut and washer on bottom of switch body.

Go to instruction 25.

For units without Micro Switch

(Drawing Ref.: Figs 7 & 8 Parts list 2).

23. Place Indicator position (23) over shaft (21), (decal position indicator (25) should be stuck on side of item (23)).

24. Place spring (24) over shaft (21) and into position indicator (23).

25. Add gasket (2) on to seal plug (1).

26. Screw seal plug (1) or Micro switch assembly into chimney of top cover (4).

NOTE: Before assembling OPSS unit into main body, ensure OPSS is in the "TRIPPED" position i.e. position indicator shows SHUT.

Refer to rebuilding procedure for slam-shut assembly to replace OPSS assembly back onto main slam-shut assembly.



Maintenance Instructions - HP OPSS Assemblies

Drawing Reference: Figs. 9 & 10

Part List Reference: Parts Lists 3 & 4

NOTE: Numbers in brackets identify items on drawings

Dismantling Procedure for HP OPSS Assembly.

If Micro Switch is Not fitted go to instruction 5.

(Drawing Ref.: Fig 10, Parts list 4.)

1. Unscrew seal plug (2) together with "O" ring (3) from chimney of top cover.
2. Remove "O" ring (3) from seal plug (2).
3. Unscrew Nuts and washers from seal plug (2), so micro switch (1) together with "O" ring (4) can be removed from seal plug (2).
4. Carefully remove "O" ring (4) from micro switch (1).

Go to instruction 7.

For units without Micro Switch

(Drawing ref.: Fig 9 Table 3).

5. Unscrew seal plug (1) together with gasket (2) from chimney of top cover (4) and lift out position indicator (25) (with label (27) glued on side) and spring (26).
6. Remove gasket (2) from seal plug (1).
7. Turn screw adjustment (3) anti-clockwise, then lift out spring (24).
8. Make note of the position of the vent in the top cover (4), relative to the horizontal tapped hole in the adaptor body (12).
9. Remove 8 nuts (19) and screws (21) holding the top cover (4) on to the adaptor body (12), lift off top cover (4), taking care that the 6 balls (18) fall into the adaptor body (12).
10. Remove all 6 balls (18) from the adaptor body (12).
11. Remove "O" ring (7) from top cover (4)(pre May 2014) or "O" ring (31) from adaptor body (12)(post May 2014) .
12. Unscrew 4 locking plate screws (9), and remove locking plate (8) and diaphragm assembly.
13. Unscrew diaphragm nut (6) from ball cage (20), lift off diaphragm cup (22) and diaphragm (5).
14. Remove "O" ring (13) and starlock washer (10) from ball cage (20).
15. Place adaptor body (12) in vice fitted with soft jaws, with shut off spring (16) uppermost, taking care not to overtighten, which could result in damage to the adaptor body.
16. Compress spring (16) with pliers, pushing down on retainer (14). Using fine pointed pliers, remove circlip (15) (as circlip is small care must be taken so that it is not misplaced).
17. Spring (16), retainer (14) and shaft (23) can now be removed.
18. Remove adaptor body (12) from vice, and check that shock absorber "O" ring (17) is either on shaft (23) or still in the adaptor body (12), then remove "O" ring (17).
19. Carefully remove "O" ring (13) from adaptor body (12).
20. It is not necessary to remove collar (11) from shaft (23) unless damaged, this can be removed by carefully removing circlips (15) and sliding off collar (11) from shaft (23).
21. Discard all "O" rings and diaphragm (8), and replace with new parts from spares kit.

Rebuilding Procedure for HP OPSS Assembly:

It is recommended that all "O" rings be lightly greased, before assembly using Dow Corning Molycote 55M.

1. Fit "O" ring (13) into adaptor body (12), taking care not to damage it whilst fitting, (use only blunt nose tools if needed).



Maintenance Instructions - HP OPSS Assemblies

Rebuilding Procedure for HP OPSS Assembly (Continued).

2. Lightly lubricate shaft (23) with silicon grease, and place through adaptor body (12), fit shock absorber "O" ring (17) into underside of adaptor body (12).
3. Place adaptor body assembly (12) in vice fitted with soft jaws, with "O" ring (13) upper most taking care not to over tighten, which could result in damage to the body. Refit spring (16) and retainer (14) over shaft (23).
4. To enable spring (16) to be compressed for refitting of circlips (15), it may be necessary to place packing piece below the shaft (23) in the vice. Using tool add circlip (15) into the groove nearest the round end of shaft (23), so spring (16) and retainer (14) are held in position.
5. Remove adaptor body assembly (12) from vice, then invert and reclamp in vice. If removed, place collar (11) over shaft (23) with counterbore of collar facing adaptor body (12). Retain collar (11) in position on shaft (23), by fitting 2 circlips (15) (using tool) into 2 grooves on shaft (23).
6. Fit "O" ring (13) into ball cage (20), retain in position by fitting starlock washer (10).
7. Place diaphragm (5) with reinforcing facing upwards, over ball cage (20). Add diaphragm cup (22) on top of the diaphragm (5), over spigot on ball cage (20).
8. Fasten diaphragm assembly (5) together by threading diaphragm nut (6) over ball cage (20).
9. Apply grease to 6 balls (18), locate balls around collar (11), grease will hold balls in position.
10. Refit diaphragm assembly (5) into top cover (4), ensure that diaphragm (5) fits correctly into the groove in the top cover (4), and around the diaphragm cup (22).
11. Using 4 screws (9), attach locking plate (8) to top cover (4), trapping diaphragm assembly (5).
12. Fit "O" ring (7) into groove in top cover (4)(pre May 2014) or "O" ring (31) into adaptor body (12)(post May 2014).
13. Place diaphragm assembly (5) and top cover (4) over shaft (23), ensuring 6 balls (18) are fitted inside ball cage (20).
14. Refit top cover (4) onto adaptor body (12), using 8 nuts (19) and screws (21).
NOTE: The position of the vent in the top cover (4), relative to the tapped hole in the side of the adaptor body (12) should be as shown in fig 5, or as noted in dismantling instructions.
15. Replace spring (24) into top cover (4) and over spigot on diaphragm nut (6).
16. Thread adjusting screw (3) into chimney of top cover (4).
If Micro Switch is not fitted go to instruction 20.
(Drawing Ref.: Fig 9 Parts list: 4).
17. Add "O" ring (4) onto micro switch (1).
18. Fit "O" ring (3) onto seal plug (2).
19. Place micro switch assembly (1) into recess in centre of seal plug (2), fasten together using nuts and washers.
Go to instruction 23.
For units without Micro Switch
(Drawing Ref.: Fig 9 Parts list 3)
20. Place position indicator (25) over shaft (23), (decal (27) should be stuck on side of item (25)).
21. Place spring (26) over shaft (23) and into position indicator (25).
22. Add gasket (2) onto plug seal (1).
23. Screw seal plug (1) or micro switch assembly into chimney of top cover (4).

NOTE: Before assembling OPSS Unit into main body, ensure OPSS is in the TRIPPED position i.e. position indicator shows Shut. Refer to rebuilding procedure for slam-shut assembly to replace OPSS assembly back onto main slam-shut assembly.