

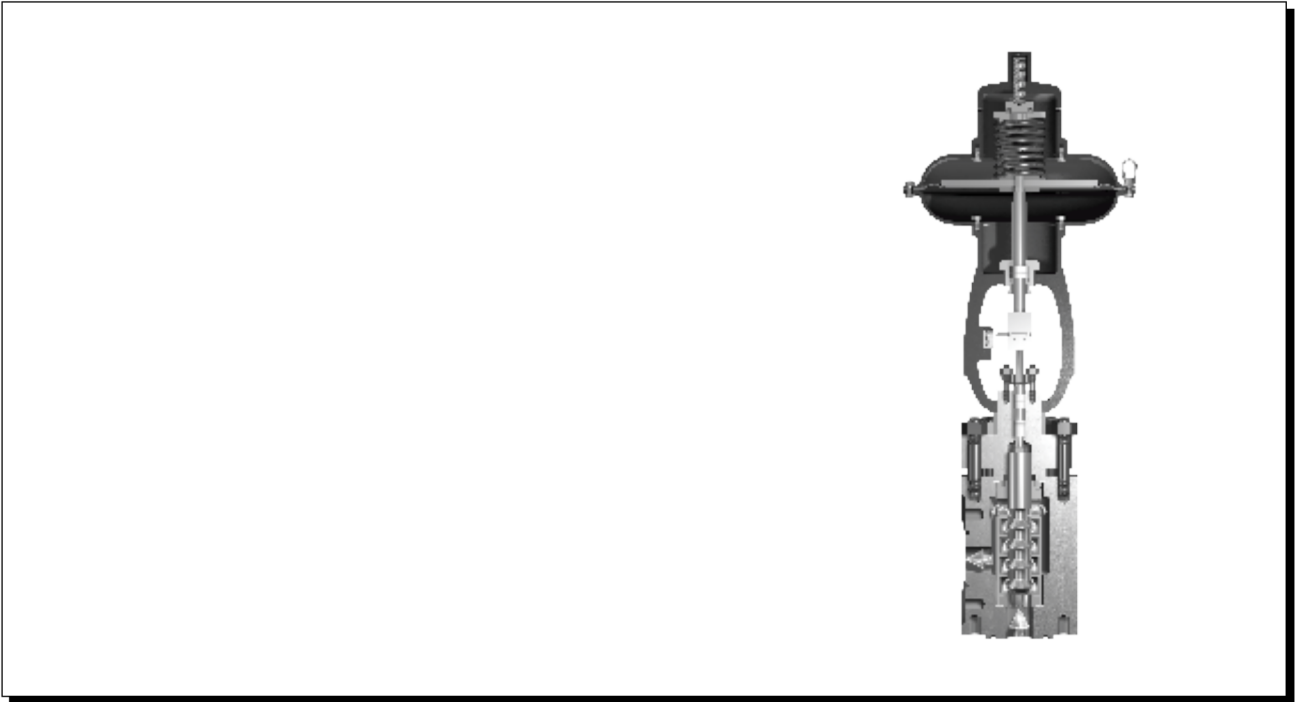

## Instruction Manual

# MIL 78000

## Multiple Stage Anti-cavitation & Low Noise Control Valves



Purchase Order No : \_\_\_\_\_



The following instructions should be thoroughly reviewed and understood prior to installing, operating or performing maintenance on this equipment. Throughout the text, safety and/or caution notes will appear and must be strictly adhered to, otherwise, serious injury or equipment malfunction could result.



## TABLE OF CONTENTS

1.	Introduction .....	2
2.	General .....	3
3.	Unpacking .....	3
4.	Installation .....	3
5.	Air Piping .....	4
6.	Valve Disassembly .....	4
6.1	Body Disassembly .....	4
7.	Maintenance & Repair .....	4
7.1	Packing Box .....	4
7.2	Lapping Seats .....	5
8.	Body Reassembly .....	6
	Parts List.....	7

**Note: Easily replaceable pressure gauges for air sets and externally mounted pressure gauges of positioners are normally dismantled, separately packed and bound to the actuator yoke as a precaution against transit damages. This may be noted while opening the boxes.**

**Warning: Do not lift large size Valves by the actuator. Lifting lugs provided on the actuators are for lifting the actuator alone.**

### 1. Introduction

The following instructions should be thoroughly reviewed and understood prior to installing, operating or performing maintenance on 78000 Matrix valve. Throughout the text, safety and/or caution notes will appear and must be strictly adhered to; otherwise, serious injury or equipment malfunction could result.

MIL has a highly skilled Aftermarket department available for start-up, maintenance and repair of our valves and component parts. Arrangements for availing their service can be made through your local representative or Aftermarket department. In addition, a regularly scheduled training program is conducted at our factory, to train your service and instrumentation personnel in the operation and maintenance. Also when performing maintenance, please ensure that only MIL replacement parts are used.

**Note :When specifying parts, always include unique serial number punched on the tag plate of the valve.**

**Caution: Skilled service personnel to be engaged for start up, maintenance and repair of the valve.**

**Caution: Always use original MIL replacement parts including soft parts like gasket, packing, etc. while performing maintenance for start-up, maintenance and repair of the valve. Any damage of soft parts in control valve may lead to its total failure.**



## 2. General

These installation, operating and maintenance instructions apply to all sizes and ratings of the MIL78000 series control valves. They apply to valve with standard trim as well as to 2”, 3”, 4” and 6” valves with balanced trim.

The MIL 78000 series valve employs the principle of “Adiabatic Flow With Friction” to reduce pressure, much like the gradual pressure loss which occurs in a long pipe line. This effect is produced by reducing the fluid pressure through multiple small steps. While conventional plug-orifice valves exhibit an average

teflon (20G) are located on either side of the seat ring gasket (20).

Some 2”, 3”, 4” or 6” valves may be equipped with optional balanced trim consisting of a special plug seal (14), O-ring (14S) and backup rings (14W).

## 3. Unpacking

**Warning: Care must be exercised when unpacking the valve to prevent damage to the accessories and component parts. Should any problems arise, contact your local representative or MIL Aftermarket department at factory. Do not remove end protection cover before installation.**

### Numbering System

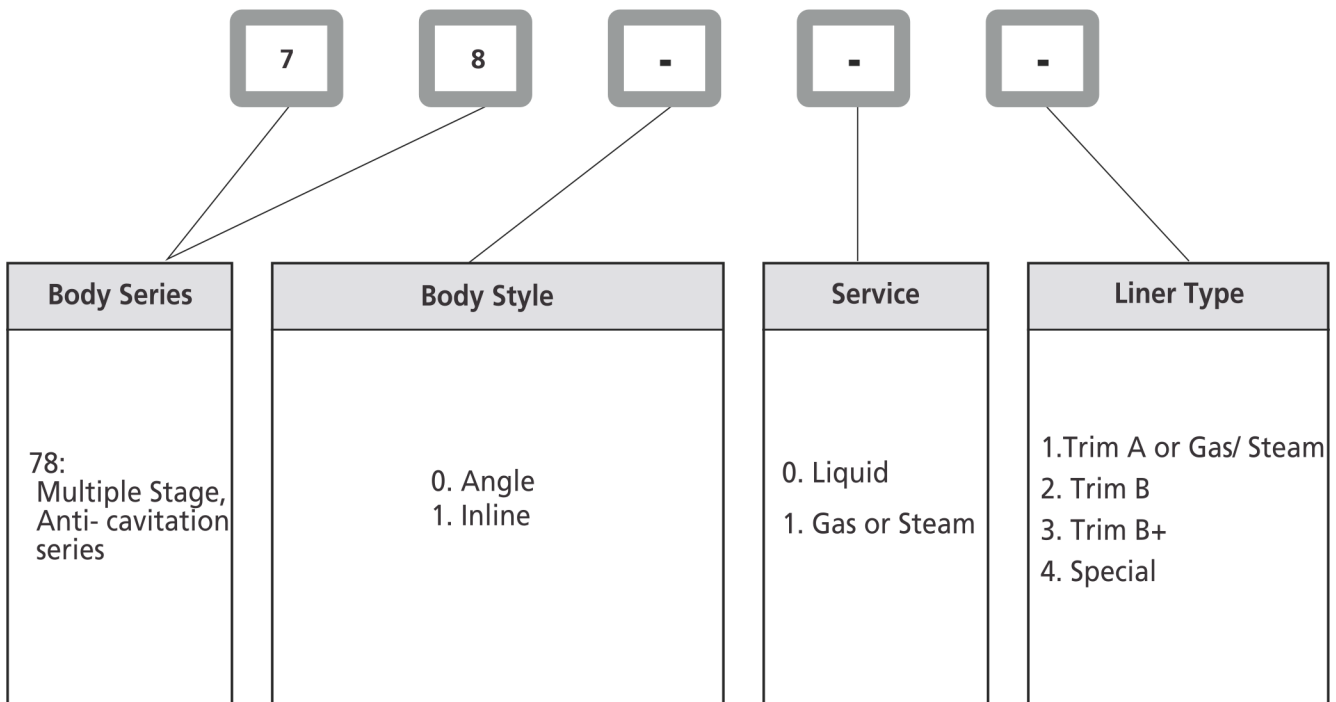

velocity headloss coefficient (k) of 0.8, 78000 series valve has maximum k value of 20. This means that each step is affected by approximately 5% of the pressure drop experienced by a conventional valve plug. As a result, there is neither cavitation nor the associated phenomena of noise and trim erosion.

The cutaway illustrations on page 7 show the construction of the valve. A multi-step plug slides in and so guided by a multi-bore liner (16). The liner and spacer tube retains the hard faced seat ring (19). The entire assembly is held in the body (18) by the bonnet (8). Spiral wound gaskets (11 & 20) seal-off the fluid at the bonnet and seat ring joints. Additional gaskets of

## 4. Installation

### Valve Body

1. Before installing the valve in the line, clean piping and valve of all foreign materials such as welding chips, scale, grease or dirt.
2. For inspection of valve without interrupting the process, provide a hand operated stop valve on each side of the MIL 78000 series valve with a hand operated throttling valve mounted in a bypass line. (See Fig. 1)



3. Install the valve so that the fluid will enter the valve under the plug. The outlet connection is always on the side of the body.

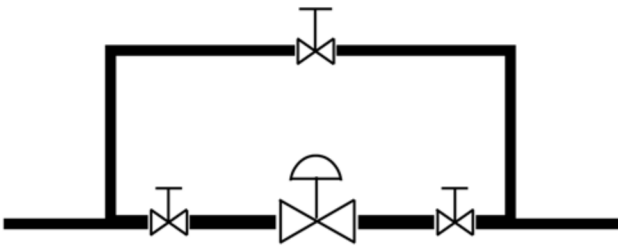

Figure 1

## 5. Air Piping

Air piping shall be as per the specification of air filter.

## 6. Valve Disassembly

If it becomes necessary to disassemble the valve for maintenance, follow the procedure outlined below. Do not alter the position of the actuator spring adjusting screw unless the actuator is to be disassembled.

The first step is to remove actuator, accessories & pneumatic/electrical connections. Access to the internal components of body should be accomplished with the actuator removed. To carry out this operation, refer instruction manual for actuator.

**Caution:** New gaskets, packing & seal ring (in case of balanced valves) should be on hand before disassembling the valve, since it is recommended that new gasket, packing & seal ring are to be used during reassembly.

**Caution:** Prior to performing maintenance on the valve, isolate the valve, vent the process pressure and cut off air supply and signal air or electrical lines to the unit.

### 6.1 Body Disassembly

- A. Remove packing flange nuts (3), packing flange (4) and then packing follower (5) from the bonnet.
- B. Remove body stud nuts (10), bonnet (8), plug and stem from the body.

**Caution:** Remove parts carefully to avoid damage to the guiding surfaces of the plug.

- C. Lift out gasket (11), liner (16), spacer tube (15), seat ring (19) and the three seat ring gaskets (20 & 20G). Remove roll pin (12) and separate liner (16) from spacer tube (15). If no new gaskets are available, care should be used to preserve the old gaskets for reuse. It is recommended, however, that new gaskets be installed, each time the valve is disassembled for maintenance.
- D. Remove old packing (6) with lantern ring (7) from the top of the bonnet.
- E. Examine the plug, seat ring and liner for wear and lap the seating surfaces if necessary.

## 7. Maintenance & Repair

The purpose of this section is to assist maintenance personnel by suggesting methods of component inspection and maintenance which largely depends on the tools and machine shop equipment available.

**Caution:** If a valve needs frequent maintenance, please consult MIL with current operating parameters for checking valve selection. Process conditions should be stabilized and determined accurately in case they were not correctly anticipated when original valve was selected.

Each selection should be completely read and understood before proceeding.

### 7.1 Packing - Box (Figure 2)

Packing box maintenance is one of the principal actions in routine servicing. Tightness of the packing is maintained by packing compression. Compression is achieved by evenly tightening the packing flange nuts (3) against the packing flange. (4). Care must be taken not to over tighten as this could prevent smooth operation of the valve. If all compression is used up and the valve leaks, then new packing (6) is required.

**Caution:** Valve must be isolated and the pressure vented before performing packing box maintenance.

Proceed as follows:

- A. Loosen and remove packing flange nuts (3).
- B. Raise packing flange (4) and packing follower (5) up through the valve stem (1).

**Caution:** Valve must be isolated and the pressure vented before performing packing box maintenance.



- C. By means of a hooked instrument, remove packing (6) ensuring not to damage the sealing surfaces of the packing box or plug stem (1).
- D. Replace correct amount of packing (6) above and below the spacer (7).

**Note: Assemble and compress rings one at a time into packing box. If rings are skive cut, the skive cut of each packing ring must be placed about 120 degrees apart.**

- E. For Eco-lock type packing (6), do not change the sequence of packing arrangement. The packing is available as a set of lower packing and upper packing. Use the packing as a set only.

**Note: MIL Eco-lock type packing (Figure 1) is a high performance system to keep fugitive emissions within allowable limits. The packing is provided with the lower packing and upper packing as a set.**

**Caution: For Eco-lock packing, lower and upper packing to be replaced as a set only. It consists of 'V' and double 'V' packing rings with varying density, which is designed to prevent fugitive emission from the packing effectively.**

- F. Replace packing follower (5) and packing flange (4).
- G. Replace and tighten packing flange stud (2) & nut (3).

**Note: Do not over-tighten.**

- H. Place valve back in service and tighten packing only as much as is necessary to stop leaking.

**Note: In an emergency, string packing may be used as a temporary repair only. It must be replaced with the correct packing as soon as possible.**

**Note: If rings are not skive cut, packing ring replacement may require disconnecting the plug stem from the actuator stem and removal of the actuator.**

**Note: A spring loaded follower assembly is used to maintain a constant load on the packing, and is necessary for thermal cycling applications, as the definition of thermal cycling can vary and processes are potentially subject to unpredicted thermal gradients. Both standard and eco- Lock systems are available with the spring loaded followers (Figure 2).**

**Caution: Packing box should be clean and free of burrs, rust and any foreign matter. Parts can be cleaned with denatured alcohol.**

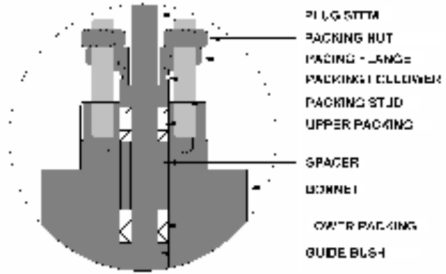

Standard Packing

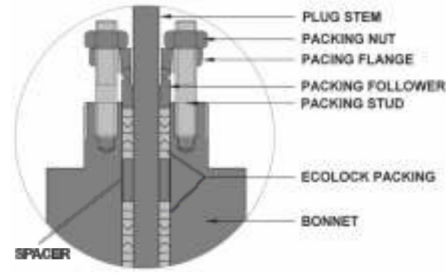

Eco-Lock Packing

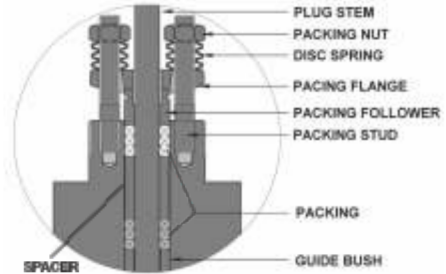

Spring Loaded Packing (Optional)

Figure 2

**7.2 Lapping Seats**

If after long service, valve leakage becomes excessive, a hand operation called lapping is necessary. To facilitate this operation, the plug and seat ring should be free of scratches or dents and contact surfaces of the seats should be as narrow as possible. Due to the unique trim design, re-machining should remove very little material. Do not remove more than 0.030” (.1mm) from each part. If this is not sufficient, replace one or both parts.

If after long service, valve leakage becomes excessive, a hand operation called lapping is necessary. To facilitate this operation, the plug and seat ring should be free of scratches or dents.



For the lapping operation, a good grade of fine compound is required. The compound is applied at several spots equally spaced around the periphery of the ring.

**Caution: Do not allow compound to get the liner and upper steps of the plug.**

Insert in the valve body, the seat ring (19), spacer tube (15), liner (16), plug and stem assembly (17 & 1). Do not use gaskets during this operation. Install the bonnet (8) and fasten it temporarily to the body. To facilitate lapping, screw a drilled and tapped rod with a T-handle onto the top of the valve stem and secure with a locknut. Lapping is accomplished by rotating the plug in short, oscillating strokes. After 8 or 10 strokes, the plug should be lifted and turned 90° before repeating the operation. This intermittent lifting is important to keep the plug and seat ring concentric during lapping.

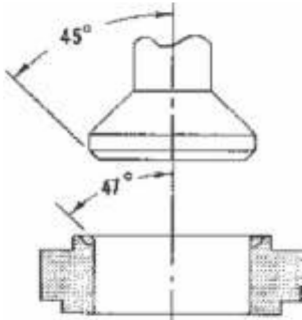

Figure 3

Plug and Seat Ring Machining

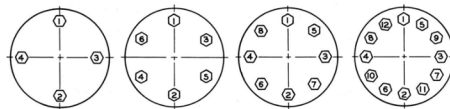

Figure 4

## 8. Body Reassembly

A. Insert seat ring gaskets (20 & 20G), seat ring (19), liner (16), spacer tube (15) and gasket (11) into the body (18).

**Note: It is very important that the liner and spacer tube are correctly positioned relative to one another so that the flow area is maximum. It is also necessary to install the spacer tube such that its 4 holes are at the bonnet end of the body. Proper orientation is achieved by means of pin (12) (1" size).**

- B. Insert new packing in the bonnet, first two rings of packing, then the lantern ring (7), then more packing rings to fill the packing box. Replace packing follower (5), packing flange (4) and packing flange nuts (3).
- C. For a balanced valve, install O-ring (14S), backup ring (14W) and tec-ring gasket (14) in the bonnet.
- D. Install the bonnet on the valve body (The plug stem (1) will push up through the packing which is held in place by the packing follower and flange). Tighten body nuts evenly and in crisscross fashion until metal to metal contact occurs. This will assure even compression of the gaskets (20 & 11).

BOLTING TORQUE VALUES FOR 78000 SERIES VALVES					
SL NO	Valve Size	Rating *	Stud Size(")	No. of Studs	Torque(Nm)
1	1"	<=600#	7/8-9UNC-2A	4	70
2	1"	900#-2500#	7/8-9 UNC-2A	4	260
3	1.5"	<=600#	1 1/8-8 UN-2A	4	120
4	1.5"	900#-2500#	1 1/8-8 UN-2A	4	500
5	2"X1.5"	900#-2500#	1 1/8-8 UN-2A	4	500
6	2"	<=600#	1-8 UNC-2A	8	120
7	2"	900#-2500#	1-8 UNC-2A	8	470
8	3"X 2"	<=600#	1-8 UNC-2A	8	120
9	3"X 2"	900#- 2500#	1-8 UNC-2A	8	470
10	3"	<=600#	1 1/2-8 UN-2A	8	430
11	3"	900#-2500#	1 1/2-8 UN-2A	8	1760
12	4"X2"	900#-2500#	1-8 UNC-2A	8	470
13	4"X3"	<=600#	1-8 UNC-2A	8	290
14	4"X3"	900#-2500#	1.5-8 UN-2A	8	1760
15	6"X3"	<=600#	1-8 UNC-2A	8	290
16	6"X3"	900#-2500#	1 1/2-8 UN-2A	8	1760
17	6"	<=600#	1 1/2-8 UN-2A	8	840

\* Rating Class is as per ASME B16.34

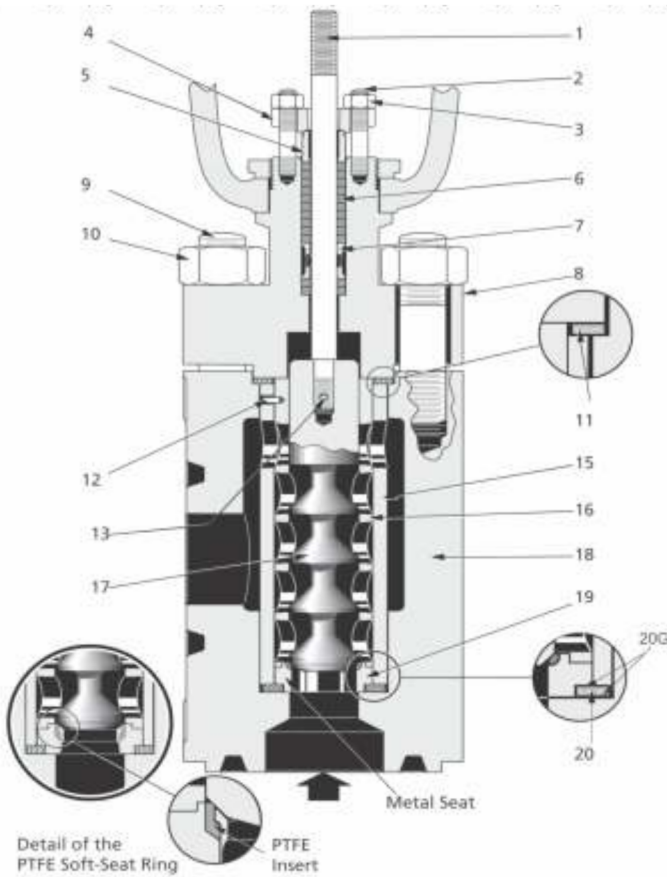

78000 Series Balanced Plug Construction

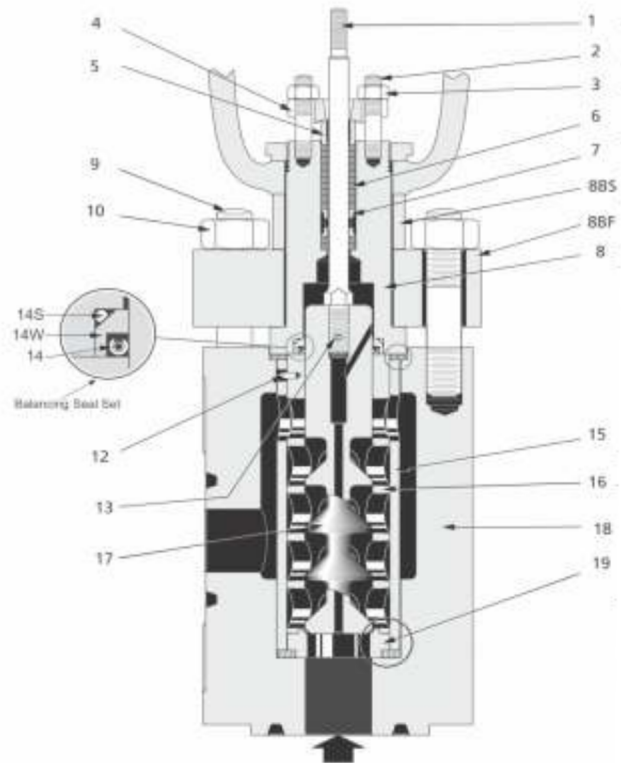

78000 Series Balanced Plug Construction

Figure 5

### Parts List

Ref. No	Part Name
* 1	Valve Plug Stem
2	Packing Flange Stud
3	Packing Flange Nut
4	Packing Flange
5	Packing Follower
* 6	Gland Packing
7	Packing Spacer/ Lantern Ring
8	Bonnet
8BF	Bonnet Flange
8ST	Bonnet Spacer Tube
9	Body Stud
10	Body Nut
11	Body Gasket

Ref. No	Part Name
12	Roll Pin
* 13	Plug Pin
* 14	Tec Seal Ring
* 14	W Backup Ring
* 14S	O Ring
15	Spacer
* 16	Liner
* 17	Valve Ring
18	Valve Body
* 19	Seat Ring
* 20	Seat Ring Gasket (Spiral Wound)
* 20	GSeat ring Gasket(Teflon)

\* Recommended Spare Parts