



MIL 8013

Electro Pneumatic Valve Positioner





Table of Contents

Introduction	01
Features	02
Technical Information	03
• Model Decodification	
• Performance Characteristics	
• Electrical Safety and Enclosures	
Construction	04
Dimensions and Mounting Orientations	05



Introduction

MIL 8013 single acting electro-pneumatic positioner provide precise and reliable valve positioning and superior dynamic response. The basic model MIL 8013 positioners are used with reciprocating control valves. Its linkage is designed for actuators with a straight axial motion. Feedback linkage is connected directly to the actuator stem. The model MIL 8013 has a stroke and zero adjustment assembly and may be split ranged with various controller signals.



Features

Dynamic Response and Positioning Accuracy

The MIL 8013 positioners are force-balance electro pneumatic devices which, by directly comparing valve stem position with controller DC output signal, provide dynamic response and positioning accuracy not obtainable with transducer and pneumatic positioner combination.

Split-ranging Controller

In addition, the positioner provide an accurate means of split ranging controller output signal for sequential operation of two or more control valves by a single controller.

Corrosion Resistance

This model electro pneumatic valve positioners are suitable for most corrosive atmosphere due to its internal nozzle bleed. This provides constant purging.

Direct Action and Reverse Action

Positioners are available for either direct action (increase in electrical signal increases output pressure) or reverse action (increase in electrical signal decreases output pressure) on direct (air-to-close) or reverse (air-to- open) actuators, diaphragm or cylinder types.



Vibration Resistant

MIL's nozzle design provides a detection system which is not affected or damaged by valve vibration. Zero and span changes are essentially independent of vibration.



Model Decodification

1 st	2 nd	3 rd	4 th	5 th	6 th
-	-	-	-	-	-
Basic Type	Actuator Size	Actuator type & Supply Pressure	Input Signal	Stroke Range	Protection Class
8013	3. 11 4. 13 5. 15 6. 18 7. 24 9. Micro pak	1. 37 (<20 psig) 2. 37 (21~35 psig) 3. 37 (36~55 psig) 4. 37 (55~75 psig) 5. 38 (<20 psig) 6. 38 (21~35 psig) 7. 38 (36~55 psig) 8. 38 (55~75 psig)	1. 4~20 mA 2. 4~12mA 3. 12~20mA 4. Special	1. 0.125 2. 0.375 - 3 3. ≥ 4	1. IP 65 2. IP 65 + Exia (Direct) 3. IP 65 + Exia (Reverse) 4. IP 55 + EX d

Performance Characteristics

Ambient Temp. range	: -40°C to + 80°C
Air consumption	: 0.21 scfm @ 20 psig, 0.29 scfm @ 35 psig
Exhaust capacity	: 3.3 scfm @ 20 psig, approximately 5.4 scfm @ 35 psig
Maximum supply pressure	: 75psi
Input Signal	: 4 -20 mA(24 mA max)
Standard stroke lengths	: 6~110 mm (depends on back liver length)
Linearity (Accuracy)	: ± 1% FS up to 35 PSI, ± 2% FS >35 PSI
Hysteresis	: ± 1% FS

Sensitivity /Dead band	: 0.2% FS
Output Characteristic	: Linear
Input impedance	: 216Ω (4~20 mA)
Pneumatic Connection	: 1/4" NPT(F)
Electrical Conduit Entry	: 1/2" NPT(F)*
Weight	: 3.5 kg

* Other options are available by adaptors

Electrical Safety And Enclosures

A. Enclosure

Ingress Protection IP 65 as per IS 13947

B. Hazardous area

Intrinsically safe : Ex ia IIC as per IS 5780/ IEC 60079 -II

Flame proof : Ex d IIA &IIB as per IS/IEC 60079-I (Weather proof IP 55)



Construction

The die cast Aluminium housing provides outdoor weather resistance and a sealed conduit connection. Electrical circuit is easily adapted to a variety of input signals. It utilizes a powerful, Hyflux, Alnico V magnet with high quality force coil with a high dielectric bobbin and mechanically protected windings.

Terminal board has a jack type terminal post to receive coil leads, and also serves as a mounting unit for components necessary to adapt the positioner to various electrical signals.

The case has a 0.5" or 0.75" NPT conduit for electrical connection by cable gland or other means.

Relay is high capacity type for fast stroking speeds. It may be mounted in any one of four positions to facilitate piping. A plunger provides for cleaning the sapphire orifice in the removable metering tube.

Balanced beam design permits installation in any position without shift in calibration. Beryllium copper flexure bearings provide friction-free fulcrum points for the beam. An adjustable beam stop prevents damage to coil.

Provision is made for the adjustment of valve travel.

Zero adjustment is easily accomplished and provides 100% zero suppression or elevation for split ranging or reverse action.

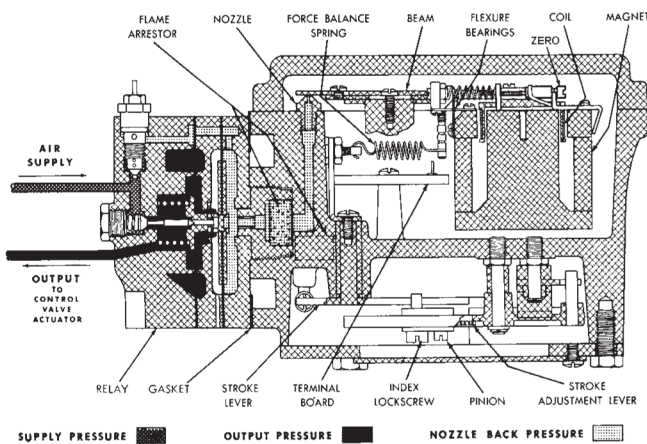

Working Principle

The positioner is a force-balance electro-pneumatic device which provides an accurate means of obtaining a valve stem position directly proportional to a DC input signal.

Direct Action

With direct positioner action, an increase in the input signal produces a force on the beam, moving the flapper to cover the nozzle. The increase in nozzle back pressure increases positioner output pressure to the actuator. The resultant valve stem motion is transmitted to the force-balance spring, extending the spring until the force exerted on the beam balances the opposing force of the coil. As these two forces equalize, nozzle back pressure decreases. The system then is in equilibrium and positioner output is stabilized at an amount necessary to maintain the desired control valve plug position. When the forces on beam are in equilibrium, there is, theoretically, no flow of air into or out from the relay. Actually, a small bleed is provided between supply and output to increase relay responsiveness.

Reverse Action

Reverse Action with reverse positioner action, an increase in the input signal produces a decrease in output pressure.

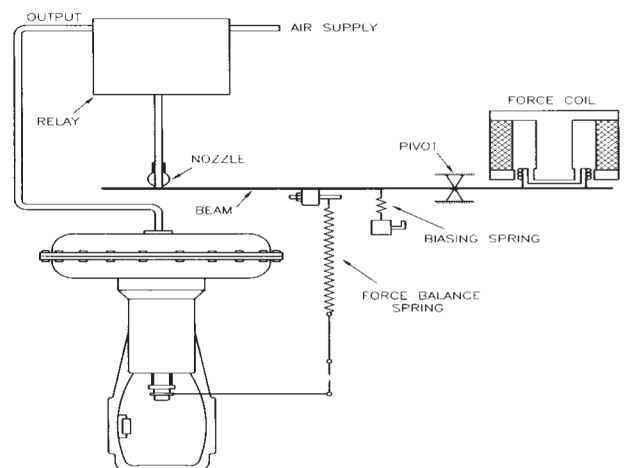



Stroking Times with 37/38 Actuator

Actuator size	Valve Stroke (inches)	Supply pressure 20 psi
		Stroking time (seconds)
11	0.75	2.8
	1	3.3
13	1	4.9
	1.5	6.3
15	1.5	9.4
	2	11.4
18	2.5	21
	3.5	29
24	4	32
	4	57

Dimensions & Mounting Orientations

Actuator size	X (inch)	Y (inch)
11	6.5	6.25
13	7.5	7.75
15	8.75	7.75
18	10.38	7.75
24	13.5	9.13

* Better stroking time can be achieved by using additional accessories such as Volume boosters and Quick exhaust valve

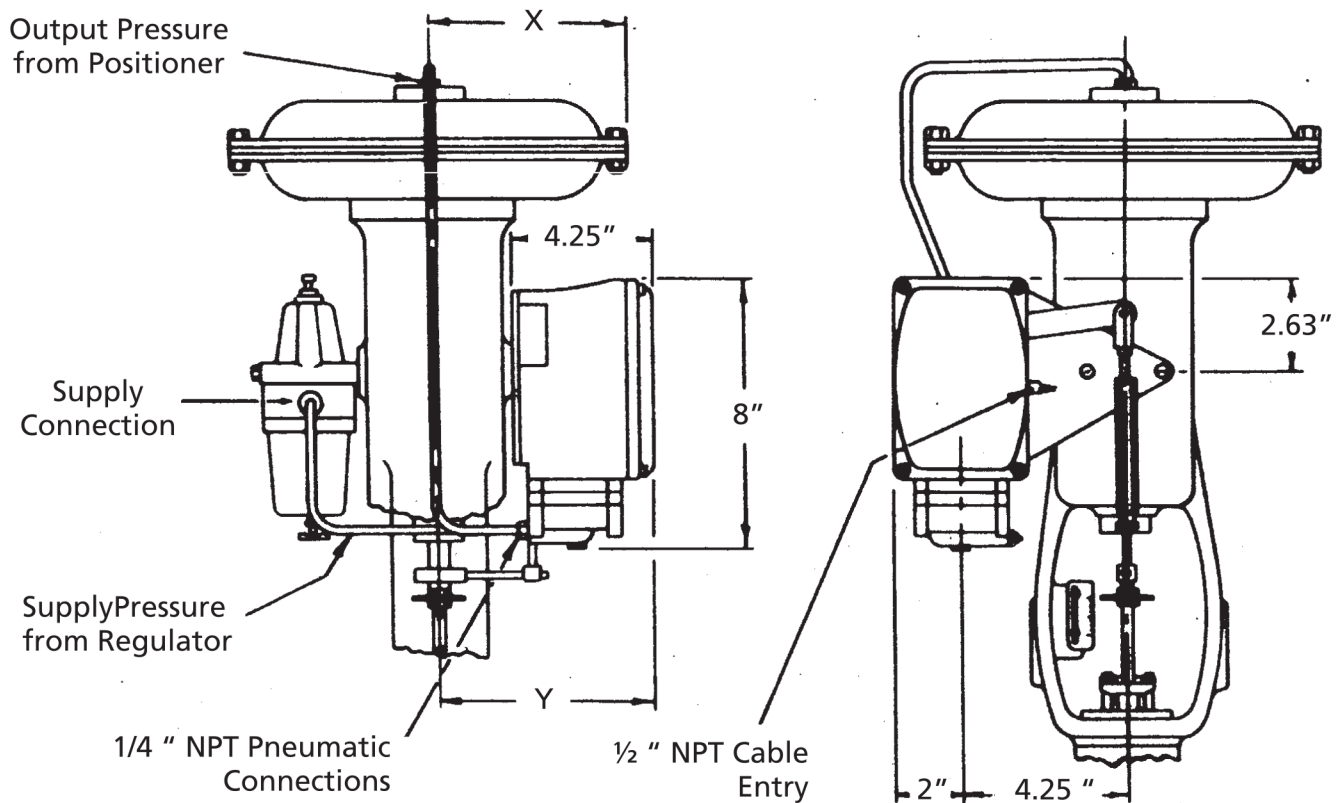



Product Highlights

- Providing high accuracy in Dynamic response and valve positioning
- Two or more positions can share single control signal(Split range application)
- Field reversible action (available for weather proof and flame proof model)
- Zero and Span changes are independent of vibration
- Suitable for most corrosive atmosphere
- High dynamic stability
- Online orifice cleaning from external using metering orifice

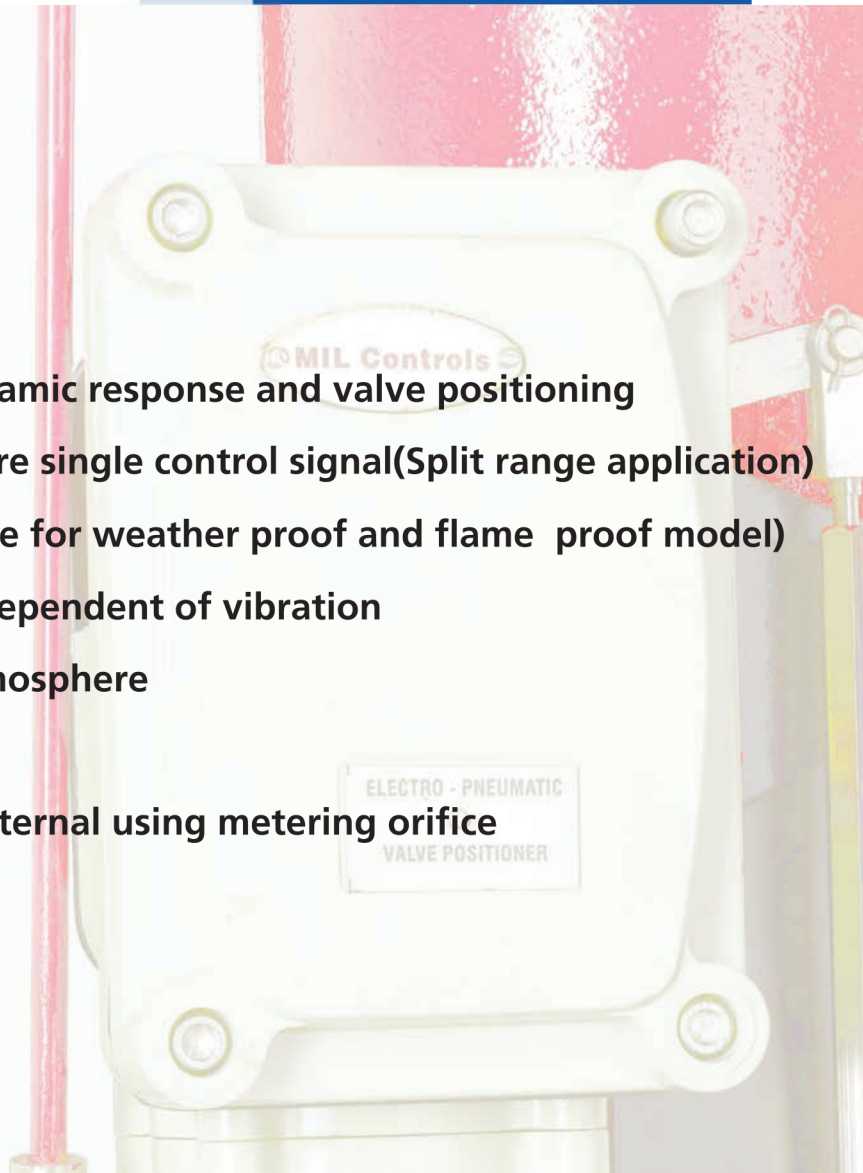

Sales & Service offices

New Delhi: MIL Controls Ltd., KSB House, A-96, Sector-4, Gautam Budh Nagar, Noida-201 301, India. Tel: +91 (120) 2541091-93, 2541501-03, Fax: +91 (120) 2550567 E-mail: salesnoida.mil@ksb.com **Mumbai:** MIL Controls Ltd., KSB Pumps Ltd., 126, Maker Chamber III, Nariman Point, Mumbai 400 021, India. Tel: +91 (22) 66588787, 66588757-59, 66588761, Fax: +91 (22) 66588788. E-mail: salesmumbai.mil@ksb.com **Kolkata:** MIL Controls Ltd., KSB Pumps Ltd., 2nd Floor, 30 Circus Avenue, Kolkata 700 017, India. Tel: +91 (33) 22809847, 22809848, 22870473, Fax: +91 (33) 22870588, 22809847. E-mail: saleskolkata.mil@ksb.com **Chennai:** MIL Controls Ltd., KSB Pumps Ltd., Guindy House, 2nd Floor, No: 95, Anna Salai, Chennai 600 032, India. Tel: +91 (44) 22352571 -72, 22300629, Fax: +91 (44) 22352749 E-mail:saleschennai.mil@ksb.com **Vadodara:** MIL Controls Ltd., KSB Pumps Ltd., 4-B, Ramakrishna Chambers, Productivity Road, Vadodara 390 005, India. Tel: +91 (265) 2330532, 2333226, Fax: +91 (265) 2350002 E-mail: salesbaroda.mil@ksb.com **Pune:** MIL Controls Ltd., KSB Pumps Ltd., Plot No - 28/21, D-II Block, MIDC, Chinchwad, Pune 411 019, India. Tel: +91 (20) 27409100, Fax: +91 (20) 27470890 E-mail: salespune.mil@ksb.com

Middle East & Asia Pacific

China: KSB Valves (Shanghai) Co.Ltd 29F. Xing-Yuan Technology Building, 418 Guiping Road, Shanghai, China, Post Code: 200233, Tel: +86-21-6485 1778, Fax: +86-21-6485 9115. **Dubai:** KSB Middle East FZE, P.O.Box: 18315, Jebel Ali, Dubai, U.A.E. Tel: +971-4-883 0455, Fax: +971-4-883 0456 **Indonesia:** PT KSB Indonesia, Jalan Timor Blok D2-1, Kawasan Industri MM 2100 Cibitung, Jawa Barat, Indonesia. Tel: +62 21 89983570, Fax: +62 21 89983571 **Korea:** KSB Korea Ltd, Soo Young Building, 64-1, Hannam-Dong, Yongsan-Ku, Seoul 140-210, Korea. Tel: +82-2-790 4351, Fax: +82-2-790 4350 **Malaysia:** KSB Malaysia Pumps & Valves SDN BHD 29, Jalan PJU 3/47, Sunway Damansara, 47810 Petaling Jaya, Selangor Darul Ehsan, Malaysia., Tel: +60-03-7805 3397, Fax: +60-03-7805 1373 **Singapore:** KSB Singapore (Asia Pacific) PTE Ltd., 4 Woodlands Walk, Singapore 738248. Tel: 6757 7200, Fax: 6482 3005 **Taiwan:** KSB Taiwan Co.Ltd, No: 154-6 Sec 1, Datong Rd, Xizhi Dist, 10635, New Taipei City, Tel: +886-2-2649 2255, Fax: +886-2-2649 8833 **Thailand:** KSB Pumps Co Ltd., Bangkok 10530, Thailand. Tel: +66-2-988 2324, Fax: +66-2-988 2213