

# Series 42S Low Water Cut-Off/Pump Controller

For Steam Boilers

Typical Applications:

- Pump controller/low water fuel cut-off for steam boilers
- Low water cut-off

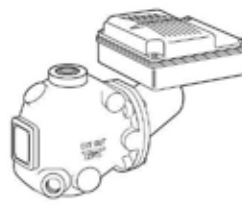

Series 42S



Series 42S-N



Series 42S-A



## **WARNING**



- Before using this product read and understand instructions.
- Save these instructions for future reference.
- All work must be performed by qualified personnel trained in the proper application, installation, and maintenance of plumbing, steam, and electrical and/or systems in accordance with all applicable codes and ordinances.
- To prevent serious burns, the boiler must be cooled to 80°F (27°C) and the pressure must be 0 psi (0 bar) before servicing.
- To prevent electrical shock, turn off the electrical power before making electrical connections.
- This low water cut-off must be installed in series with all other limit and operating controls installed on the boiler. After installation, check for proper operation of all of the limit and operating controls, before leaving the site.
- We recommend that secondary (redundant) Low Water Cut-Off controls be installed on all steam boilers with heat input greater than 400,000 BTU/hour or operating above 15 psi of steam pressure. At least two controls should be connected in series with the burner control circuit to provide safety redundancy protection should the boiler experience a low water condition. Moreover, at each annual outage, the low water cut-offs should be dismantled, inspected, cleaned, and checked for proper calibration and performance.
- To prevent serious personal injury from steam blow down, connect a drain pipe to the control opening to avoid exposure to steam discharge.
- To prevent a fire, do not use this low water cut-off to switch currents over 7.4A, 1/3 HP at 120 VAC or 3.7A, 1/3 HP at 240 VAC, unless a starter or relay is used in conjunction with it.
- This product can expose you to chemicals including Lead, which is known to the State of California to cause cancer and birth defects or other reproductive harm. For more information go to: [www.P65Warnings.ca.gov](http://www.P65Warnings.ca.gov).
- Previous controls should never be installed on a new system. Always install new controls on a new boiler or system.

Failure to follow this warning could cause property damage, personal injury or death.

**CAUTION:**

- A more frequent replacement interval may be necessary based on the condition of the unit at time of inspection. McDonnell & Miller's warranty is one (1) year from date of installation or two (2) years from the date of manufacture.

# OPERATION

**Maximum Pressure:** 50 psi (3.5 kg/cm<sup>2</sup>)

## Electrical Ratings

Voltage	Pump Circuit Rating (Amperes)		Pilot Duty
	Full Load	Locked Rotor	
120 VAC	7.4	44.4	345 VA at 120 or 240 VAC
240 VAC	3.7	22.2	

Motor Horsepower	
Voltage	Hp
120 VAC	1/3
240 VAC	1/3

## Settings and Differential Pressures

Values are  $\pm 1/8"$  (3.2mm).

Series 42S			
Pressure	Setting	Approximate Distance Above Cast Line In. (mm)	Differential In. (mm)
<b>50 psi (3.5 kg/cm<sup>2</sup>)</b>	Pump Off	1 <sup>3</sup> / <sub>8</sub> (35)	3/4 (19)
	Pump On	5/8 (16)	
	Burner On	7/8 (22)	7/8 (22)
	Burner Off	0 (0)	

1 3/8" (35mm)

PUMP OFF

BURNER OFF

NORMAL BOILER WATER LINE

BURNER CUT-OFF LEVEL AT CAST LINE

3/4" (19mm)

PUMP OFF

PUMP ON

NORMAL BOILER WATER LINE

7/8" (22 mm)

BURNER ON

BURNER OFF

NORMAL BOILER WATER LINE

BURNER CUT-OFF LEVEL AT CAST LINE

# INSTALLATION –

## TOOLS NEEDED:

Two (2) pipe wrenches, one (1) flathead screw driver, and pipe sealing compound.

**IMPORTANT:** Follow the boiler manufacturer's instructions along with all applicable codes and ordinances for piping, blow down valve and water gauge glass requirements.

## STEP 1 - Determine the Elevation at Which the Low Water Cut-Off/Pump Controller Must be Installed

The 42S and 42S-N controls are installed so that the horizontal cast line on the body is **1 $\frac{3}{8}$ " (35mm)** below the boiler's normal water level, but not lower than the lowest, safe permissible water level, as determined by the boiler manufacturer.

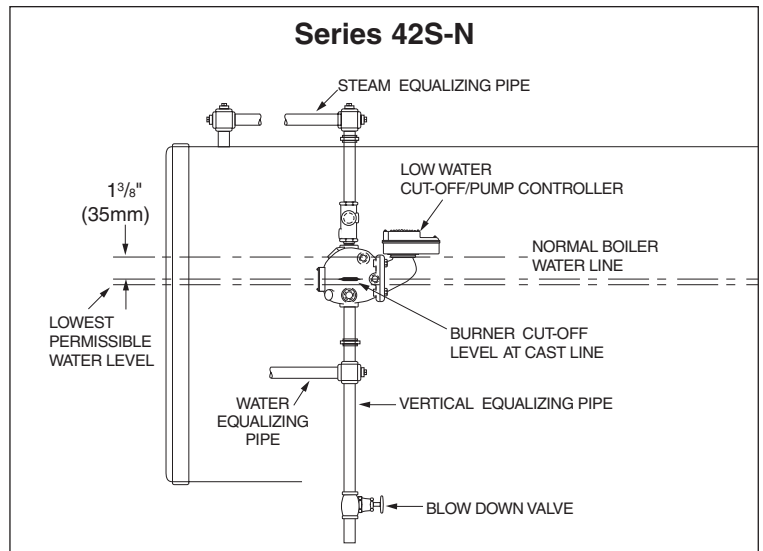
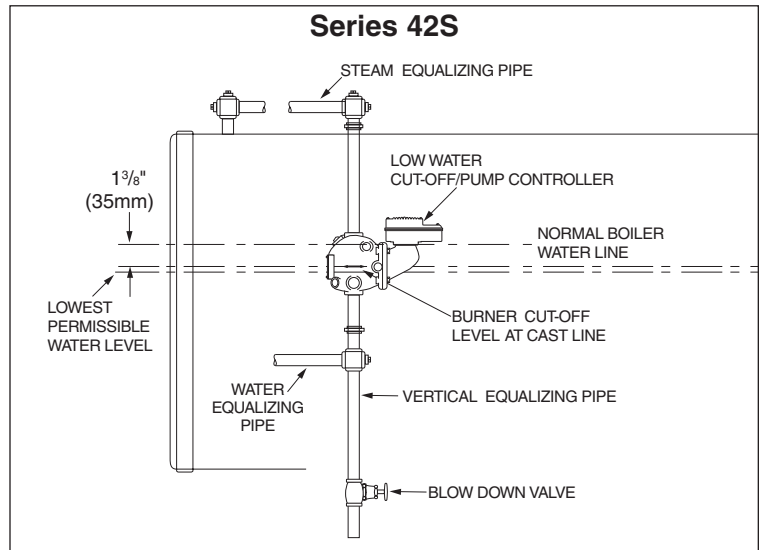

The 42S-A controls are installed in boiler's gauge glass tapplings. The horizontal cast line should be approximately **1" (25 mm)** above the bottom of the glass. Verify that this level is **not below the lowest, safe permissible water level, as determined by the boiler manufacturer.**

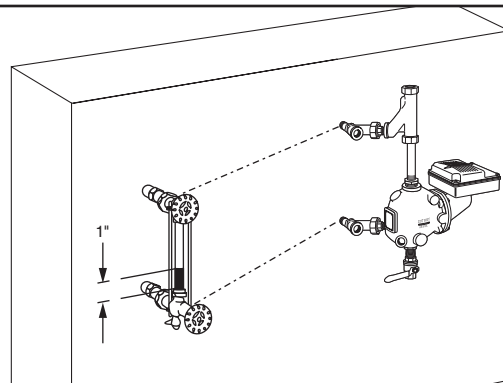

## STEP 2 - Installation

- a. Using a pipe wrench, unscrew shipping block (A) from upper 1" NPT tapping (B) of the control body.

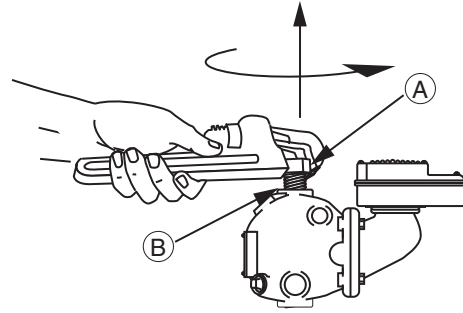

### For 42S-A Control

- a. Drain the water in the boiler until the level falls below the lower gauge glass connection (C). Allow the boiler to cool to 80°F (27 °C) and allow the pressure to release to 0 psi (0 bar).

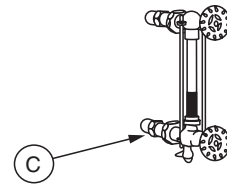

- b. Remove the water glass (D) and gauge glass connections (E) from the boiler.

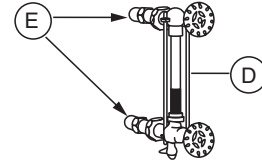

- c. Determine the position of the black 'Y' casting (H).

If gauge glass tapplings (F) and (G) are less than 10 5/8" (270 mm) apart, install the black 'Y' casting (H) as depicted in the diagram to the top right.

OR

If gauge glass tapplings (F) and (G) are greater than 10 5/8" (270 mm) apart, invert the black 'Y' casting (H) as depicted in the diagram to the bottom right.

OR

If gauge glass tapplings (F) and (G) are greater than 14" (356 mm) apart, invert the black 'Y' casting (H) as depicted in the diagram to the bottom right and install a longer brass nipple (J).

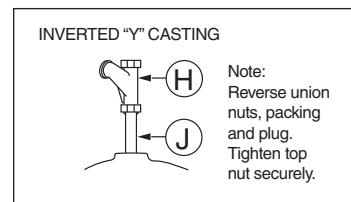
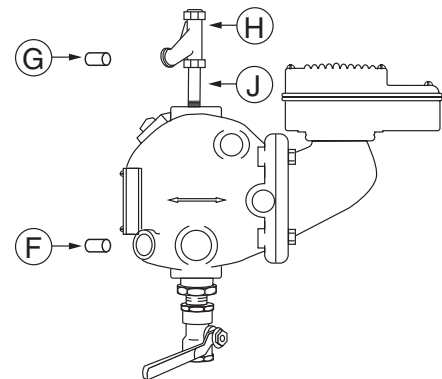

- d. • Install upper 'Y' fitting (K) into upper 1/2" NPT gauge glass tapping on boiler.
- Install lower 'Y' fitting (L) into 1/2" NPT gauge glass tapping on boiler.

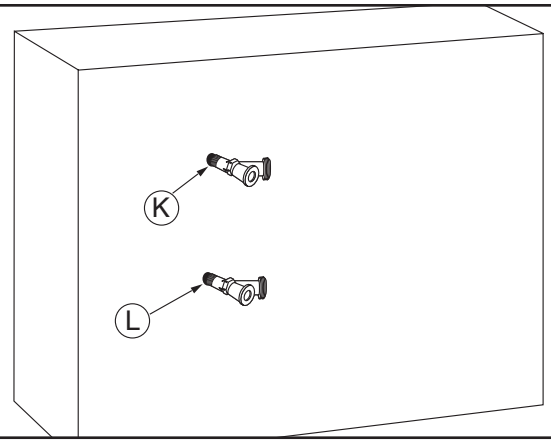

- e. • Screw reducer bushing (O) and nipple (N) into top 1" NPT tapping (P).
- Screw reducer bushing (Q), nipple (R) and blow-off valve (S) into bottom 1" NPT tapping (T).
- Screw lower union tailpiece (V) with nut (U) into either 1/2" NPT lower tapping (W, X). Screw 1/2" NPT pipe plug into unused lower tapping.
- Screw upper union tailpiece (Z) with nut (Y) into 'Y' casting (M) 1/2" NPT tapping (AA).
- Slide 'Y' casting (M) and compression nut (BB) over nipple (N).
- Connect upper and lower union nuts (U, Y) to 'Y' fittings (K, L) installed in boiler gauge glass tapings.  
**Note:** 'Y' fitting (M) will have to be moved up or down nipple (N) to mate union halves.
- Tighten compression nut (BB).

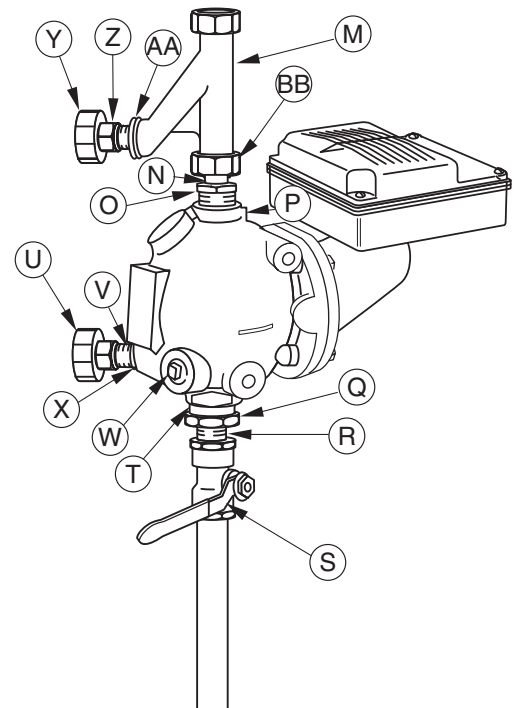

- f. Reinstall gauge glass and trim to 'Y' fittings (K, L).  
**Note:** Make sure gauge glass valves are fully open.

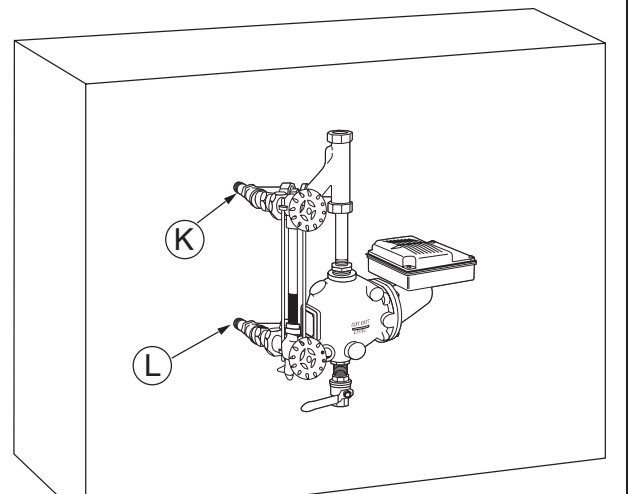

## For 42S Control

- a. Mount and pipe control (CC) on vertical equalizing pipes (DD) at the required elevation as determined in Step 1.
- b. Install a full ported ball valve (NN) directly below the lower cross of the water (lower) equalizing line.

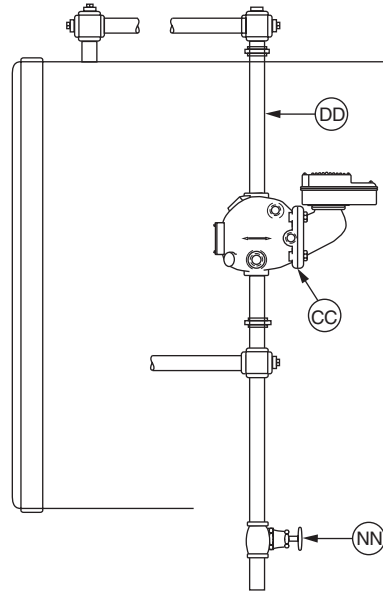

## For 42S-N Control

- a. Install fitting (EE) provided in top 1" NPT tapping. Orient 1/2" NPT tapping (FF) with 1/2" tapping on control (GG).
- b. Mount and pipe control (HH) on vertical equalizing pipes (JJ) at the required elevation as determined in Step 1.
- c. Install gauge glass and other trim such as pressure gauges or pressure controls following manufacturer's instructions. **Note:** These items are not provided and must be purchased separately.
- d. Install pipe plugs in all unused tappings on control body and fittings.
- e. Install a full ported ball valve (NN) directly below the lower cross of the water (lower) equalizing line.

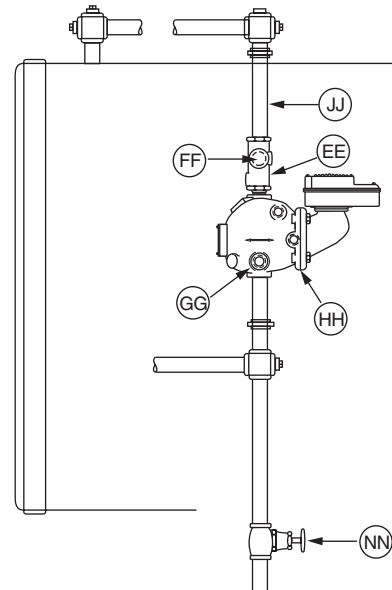

## STEP 3 - Electrical Wiring

### WARNING



- To prevent electrical shock, turn off the electrical power before making electrical connections.
- This low water cut-off must be installed in series with all other limit and operating controls installed on the boiler. After installation, check for proper operation of all of the limit and operating controls, before leaving the site.



- Modification of the switch assembly before or after installation could cause damage to the boiler and/or boiler system.
- Failure to follow this warning could cause electrical shock, an explosion and/or a fire, which could result in property damage, personal injury or death.

### Switch Operation

Boiler feed pump off,  
burner on.



Boiler feed pump on,  
burner on.

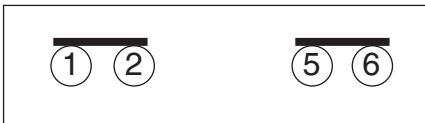

Boiler feed pump on,  
burner off.



- a. Using a flathead screwdriver, remove the junction box cover (KK).

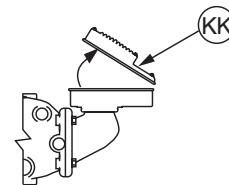

- b. Following the appropriate wiring diagram, (refer to page 8) based on your application requirements, and using BX armored cable or Thinwall electrical metal tubing connector fittings, make electrical connections to the junction box (LL).

**Note:** Follow local codes and standards when selecting the types of electrical fittings and conduit to connect to control.

**IMPORTANT:** There must be a minimum space of 1/2" (13mm) between connector fittings and electrical live metal parts.

### Snap Switches (Series 42S)

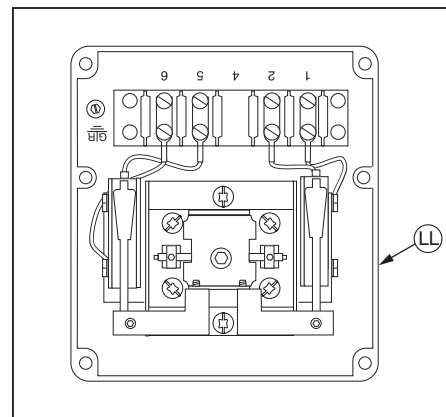

# WIRING DIAGRAMS

## Low Water Cut-Off Only

1. Main Line Switch - For burner circuits within the switch's electrical rating.

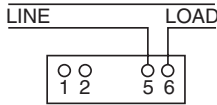

2. Pilot Switch - To holding coil of a starter when the burner circuit exceeds the switch's electrical rating.

OR

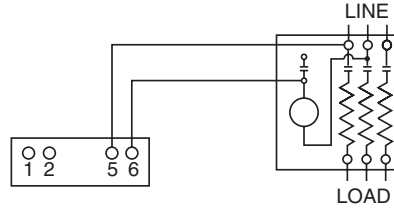

## Pump Control Only

1. Install a starter or relay in pump control circuit, as shown, to prevent damage to snap switch and help insure proper switch/control operation. Failure to do so may shorten the life of the switch when actual amperage exceeds switch rating.

2. Connect wires from holding coil of pump starter or relay to terminals 1 and 2 as shown.

**NOTE:** To help insure most effective operation, balance boiler feed pump(s) to deliver required water feed rate to match boiler steaming requirements.

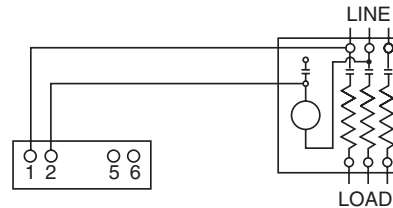

## Combination Pump Control, Low Water Cut-Off and Alarm

1. Main Line Switch - For burner circuits within the switch's electrical rating.



2. Pilot Switch - To holding coil of a starter when the burner circuit exceeds the switch's electrical rating.

OR

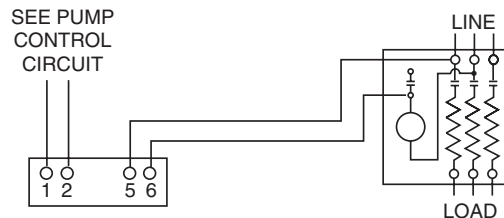

c. Re-attach the junction box cover (KK).

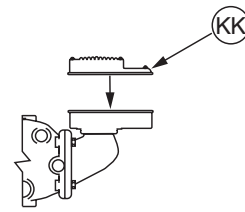

## STEP 4 - Testing

This control is factory calibrated for specific applications. The following testing procedure is only meant to serve as a verification of proper operating sequence.

Dimensions provided are typical for a boiler not being fired and/or not at pressure. Actual operating ranges are shown on page 2 in the "Operation" section.

**IMPORTANT:** Follow the boiler manufacturer's start-up and operating instructions along with all applicable codes and ordinances.

a. Turn on the electric power to the boiler. With the boiler empty the pump should go on and the burner must remain off.

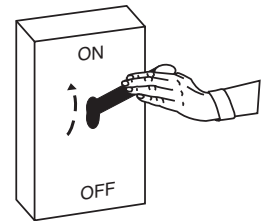

### WARNING



If the burner comes on, immediately turn the boiler off and make the necessary corrections.

Failure to follow this warning could cause an explosion or fire and result in property damage, personal injury or death.

b. The boiler should begin to fill with water. Watch the gauge glass (D) until the water level reaches approximately  $\frac{7}{8}$ " (22mm) above the horizontal cast line (MM) on the low water cut-off. When the water level reaches approximately  $\frac{7}{8}$ " (22mm) the burner should come on.

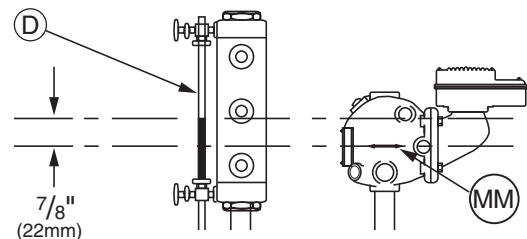

**IMPORTANT:** If water does not start filling the boiler, immediately turn off the the boiler and make the necessary corrections.

- c. Continue watching the gauge glass (D) to see that the water continues to rise to approximately  $1\frac{3}{8}$ " (35mm) above the horizontal cast line (MM). The pump should shut off.

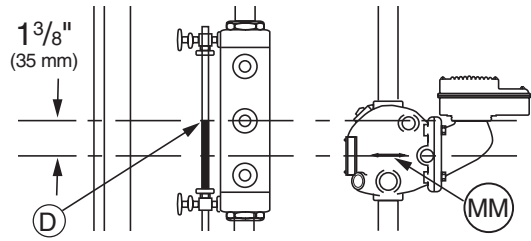

d.

### ⚠ CAUTION



To prevent serious personal injury from steam and hot water during blow-down, connect piping to the discharge side of the blow-down valve to avoid exposure to steam discharge.

Failure to follow this caution could cause personal injury.

When the water level is at its normal level and the burner is on, **slowly** open the blow down valve (NN) until it is fully open. Watch the gauge glass (D) to see that the water level drops. Close the valve after verifying that the pump comes on and the burner shuts off. If this does not occur, immediately shut off the boiler and correct the problem and retest.

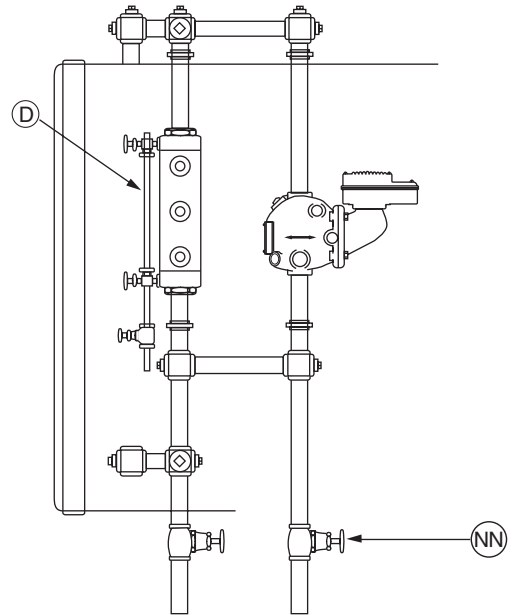

**INSTALLATION COMPLETE**

# MAINTENANCE

## SCHEDULE:

Blow down control as follows when boiler is in operation.

- Daily if operating pressure is above 15 psi.
- Weekly if operating pressure is below 15 psi.

### NOTE

More frequent blow-down may be necessary due to dirty boiler water and/or local codes.

### NOTE

High levels of chlorides in the boiler water can increase the rate of corrosion in the water-wetted components of the control.

Contact your boiler manufacturer and follow their recommendations on controlling boiler water quality.

### NOTE

The control may need to be inspected and cleaned more frequently on systems where there is the potential of excessive scale or sludge build-up. This includes systems:

- With high raw water make-up
- With no condensate return
- With untreated boiler water
- Where significant changes have been made to the boiler-water chemical treatment process
- With oil in the boiler water

- Remove head assembly and inspect water-side components annually. Replace head assembly if any of the internal components are worn, corroded or damaged or if control no longer operates properly.
- Inspect the float chamber and equalizing piping annually. Remove all sediment and debris.

Replace head mechanism every 5 years.

More frequent replacement may be required when severe conditions exist.

Replacement parts are available from your local authorized McDonnell & Miller Distributor.

The use of parts or components other than those manufactured by McDonnell & Miller will void all warranties and may affect the units' compliance with listings or regulating agencies.

# BLOW DOWN PROCEDURE:

## CAUTION



To prevent serious personal injury from steam pipe blow down, connect a drain pipe to the control opening to avoid exposure to steam discharge.

Failure to follow this caution could cause personal injury.

When blowing down a control at pressure, the blow down valves should be opened slowly. The piping needs to be warmed up and stagnant water in the drain piping needs to be pushed out. Suddenly opening a blow down valve causes steam to condense, which can create water hammer. Damage to components can occur when water hammer occurs due to improper blow down piping.

For these reasons, McDonnell & Miller recommends a dual valve blow-down system for each control.

Blow down the control when the water in the boiler is at its normal level and the burner is on.

**NOTE:** Refer to page 2 for switch operating points.

- Open upper valve (#1)
- Slowly open the lower valve (#2)
- Water in the sight glass should lower.
- As the water in the sight glass lowers, the pump should turn on.
- As the water continues to lower in the sight glass, the burner should turn off.
- Slowly close the lower valve (#2).
- Close the upper valve (#1)
- The water level in the sight glass should rise, first turning on the burner and then turning off the pump.

**NOTE:** On manual reset models, the reset button will need to be pressed after the water level has been restored before the burner will operate.

### NOTE

If this sequence of operation does not occur as described, immediately close all valves, turn off the boiler and correct the problem. Inspection/cleaning of the float mechanism may be required to determine why the control was not working properly. Retest the control after the problem has been identified and corrected.

