

## Series 61 Low Water Cut-Off

### Typical Applications:

- Primary or secondary low water cut-off for hot water and steam boilers.
- Low water cut-off
- High water cut-off
- Alarm actuator

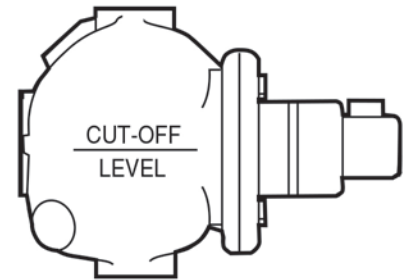

### OPERATION

**Maximum Boiler Pressure:** 20 psi (1.4 kg/cm<sup>2</sup>)





### Electrical Ratings

Voltage	Motor Switch Rating (Amperes)		Pilot Duty
	Full Load	Locked Rotor	
120 VAC	7.4	44.4	125 VA at 120 or 240 VAC
240 VAC	3.7	22.2	

NOTE: 11 MV is rated at 24 VA @ 24VAC to 120 VAC



## **WARNING**

	<ul style="list-style-type: none"> <li>• Before using this product read and understand instructions.</li> <li>• Save these instructions for future reference.</li> </ul>
	<ul style="list-style-type: none"> <li>• All work must be performed by qualified personnel trained in the proper application, installation, and maintenance of plumbing, steam, and electrical and/or systems in accordance with all applicable codes and ordinances.</li> <li>• To prevent serious burns, the boiler must be cooled to 80°F (27°C) and the pressure must be 0 psi (0 bar) before servicing.</li> <li>• To prevent electrical shock, turn off the electrical power before making electrical connections.</li> <li>• This low water cut-off must be installed in series with all other limit and operating controls installed on the boiler. After installation, check for proper operation of all of the limit and operating controls, before leaving the site.</li> </ul>
	<ul style="list-style-type: none"> <li>• We recommend that secondary (redundant) Low Water Cut-Off controls be installed on all steam boilers with heat input greater than 400,000 BTU/hour or operating above 15 psi of steam pressure. At least two controls should be connected in series with the burner control circuit to provide safety redundancy protection should the boiler experience a low water condition. Moreover, at each annual outage, the low water cut-offs should be dismantled, inspected, cleaned, and checked for proper calibration and performance.</li> </ul>
	<ul style="list-style-type: none"> <li>• This product can expose you to chemicals including Lead, which is known to the State of California to cause cancer and birth defects or other reproductive harm. For more information go to: <a href="http://www.P65Warnings.ca.gov">www.P65Warnings.ca.gov</a>.</li> <li>• To prevent serious personal injury from steam blow down, connect a drain pipe to the control opening to avoid exposure to steam discharge.</li> <li>• To prevent a fire, do not use this low water cut-off to switch currents over 7.4A, 1/3 Hp at 120 VAC or 3.7A, 1/3 Hp at 240 VAC, unless a starter or relay is used in conjunction with it.</li> </ul>



- **California Proposition 65 warning! This product contains chemicals known to the state of California to cause cancer and birth defects or other reproductive harm.**
  - **Previous controls should never be installed on a new system. Always install new controls on a new boiler or system.**
- Failure to follow this warning could cause property damage, personal injury or death.**

**CAUTION:**

- **A more frequent replacement interval may be necessary based on the condition of the unit at time of inspection. McDonnell & Miller's warranty is one (1) year from date of installation or two (2) years from the date of manufacture.**

## INSTALLATION –

### Model 61 – For Steam Boilers with 1” (25mm) Equalizing Lines

**TOOLS NEEDED:**

One (1) flathead screwdriver and two (2) pipe wrenches.

#### STEP 1 - Determine the Location of the Low Water Cut-Off

- Whether the gauge glass is mounted directly into the boiler or on an independent water column, the cut-off line on the 61 body casting should be mounted 1/2” (15mm) above the lowest visible point of the gauge glass.

#### STEP 2 - Installation of the Model 61

- Locate the gauge glass and determine the level that the 61 has to be mounted at in order to achieve the criteria in Step 1.
- Pipe the 61 following the diagrams shown to the right. Follow the diagram that represents your boiler.
- Crosses should be used at each right angle connection for inspection and cleaning.
- Make sure the blow-down valves are full port.
- Test the Model 61 before leaving the site

**Gauge Glass Mounted Directly into Boiler**

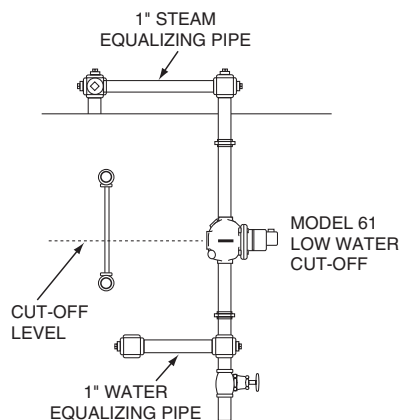

**For Boilers with Independent Water Columns**

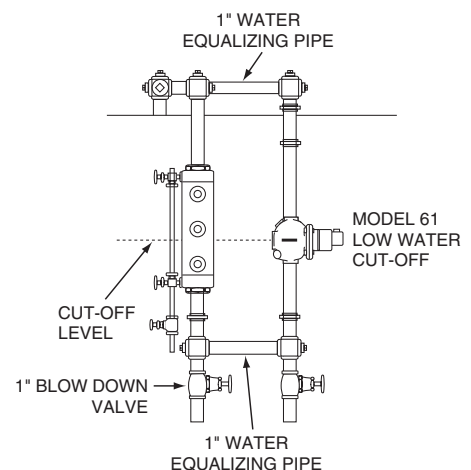

# INSTALLATION –

## Model 61 – For Hot Water Boilers with 1” (25mm) Equalizing Lines

### TOOLS NEEDED:

One (1) flathead screwdriver and two (2) pipe wrenches.

### STEP 1 - Determine the Location of the Low Water Cut-Off

- a. The line on the casting of the model 61 must be installed above the lowest permissible water level determined by the boiler manufacturer.

### STEP 2 - Installation of the Model 61

For float type controls it is recommended that Test-N-Check® (TC-4) valves be used in the upper and lower equalizing lines. They offer a functional means for testing the 61 control, and conform to the ASME CSD-1 code.

- a. Study the figures to the right and determine which figure shows how the 61 control will be attached to the boiler.

**Figure 1.** Connect the upper equalizing pipe to the riser going to the radiation or to the compression tank. Connect the lower equalizing pipe to any available opening in the side of the boiler. **NOTE:** If no opening is available in the side of the boiler, connect the lower equalizing pipe into the drain connection.

**Figure 2.** If there is a tapping available on the top of the boiler connect the upper equalizing pipe to it. **NOTE:** During initial filling or after blow down the upper equalizing pipe and possibly the 61 control will have an air pocket. Connect a vent or bleed valve on the top of the vertical equalizing pipe. If the Test-N-Check (TC-4) valve is used the vacuum breaker can be used to bleed the air pocket.

**CAUTION:** When bleeding an air pocket manually, protect yourself from being burned with hot water.

**Figure 3.** If there is no tapping available on the boiler, connect both the upper and lower equalizing pipe into the vertical riser going to the radiation or to the compression tank. **IMPORTANT:** The horizontal equalizing pipe should be below the horizontal run going to the radiation. If it is not, an air pocket will be created and a vent or bleed will have to be installed.

- b. Test the Model 61 before leaving the site.

**NOTE:** If no Test-N-Check (TC-4) valves were used, do this test before filling the system completely.

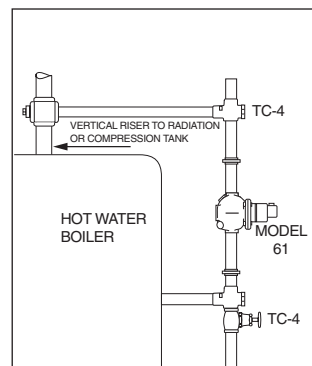

Figure 1

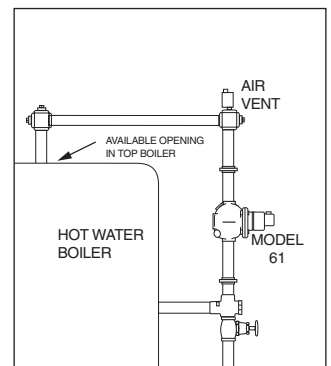

Figure 2

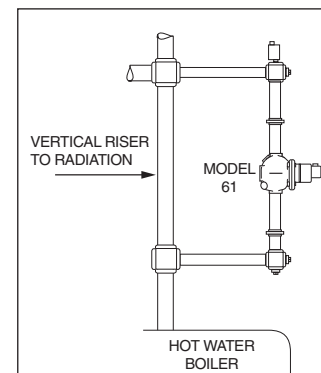
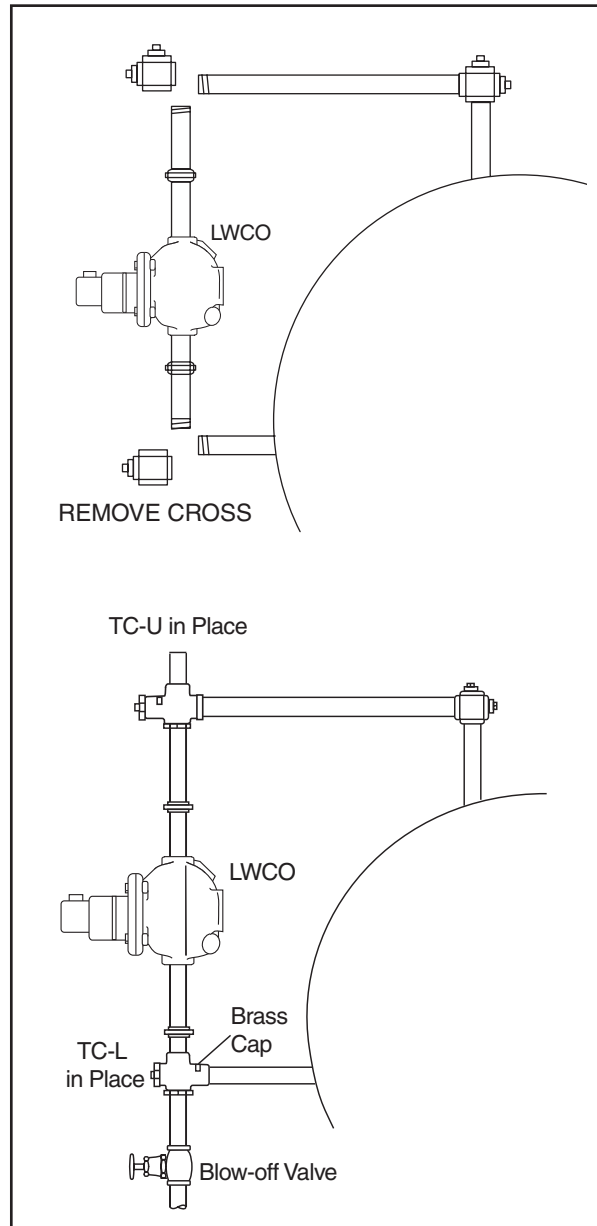

Figure 3

# TEST-N-CHECK® VALVES

## Installation of the TC-4 Test-N-Check Valve with a New Low Water Cut-off

1. Assemble the TC-U (the upper Test-N-Check valve, with the vacuum breaker) into the upper equalizing line in place of the cross described in the low water cut-off installation instructions. **NOTE:** The vacuum breaker must be on the top and the long leg must face the boiler. **NOTE:** Make sure low water cut-off position is located in accordance with the boiler manufacturer recommended cut-off level.
2. Assemble the TC-L (the lower Test-N-Check valve, without the vacuum breaker) into the lower equalizing line in place of the cross described in the low water cut-off installation instructions. **NOTE:** The brass cap must be located above the center of the lower equalizing line, and the long leg must face the boiler.
3. Assemble the blow-off valve into the bottom port of the TC-L.
4. Assemble 1" NPT pipe plugs into the remaining open port in both the TC-U and TC-L.
5. Complete the installation as described in the low water cut-off installation instructions.
6. After all piping assembly has been completed, refill the system with water, turn on all electrical supply and bring system to operating conditions. After system reaches operating pressure, inspect to make sure no leaks exist at the threaded connections. Test valves by opening blow-off valve while burner is on, to make sure valves operate correctly and low water cut-off shuts burner off.



### IMPORTANT:

- Installation should be performed by qualified personnel only, in accordance with all applicable codes.
- If vacuum breaker stem is accidentally depressed, hot water could be discharged causing burns.
- Blow-off valve drain piping should be piped to a suitable drain to handle hot water and steam discharge, and should be the same size as the equalizing pipe.

# Wiring Instructions

## WARNING



- To prevent electrical shock, turn off the electrical power before making electrical connections.
- This low water cut-off must be installed in series with all other limit and operating controls installed on the boiler. After installation, check for proper operation of all of the limit and operating controls, before leaving the site.



Failure to follow this warning could cause electrical shock, an explosion and/or a fire, which could result in property damage, personal injury or death.

### Cover Removal and Installation Procedure

- Using a flathead screwdriver, remove the one (1) screw that secures the switch cover.
- Place the cover on the switch housing and, using a flathead screwdriver, tighten the one (1) screw to approximately 2 ft•lb (2.6 N•m).

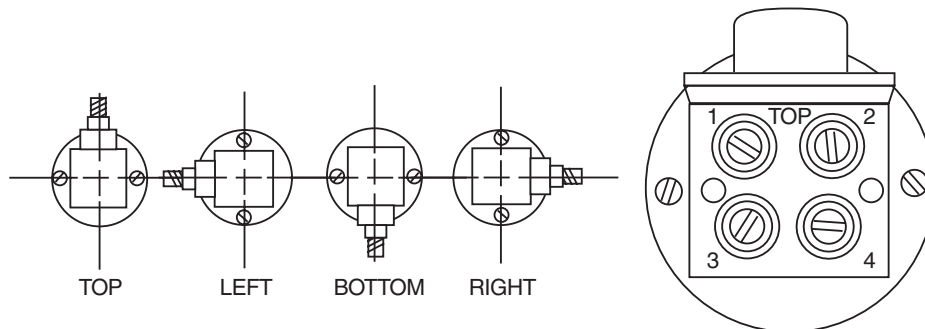
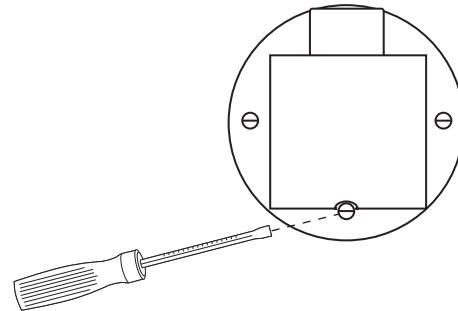

Electrical connector is movable into any one of four positions illustrated, by simply removing two black headed screws and rotating housing.

**NOTE:** This control should be wired with materials suitable for use at 75°C.

### Switch Operation

The No. 11 switch can be identified by a black terminal panel. The switch contains two (2) single pole single throw switches to control the water feeder and the low water cut-off. The low water cut-off switch is between terminals marked “1” and “2”. A second switch is located between terminals marked “3” and “4”. This can be used to operate a low water alarm or a McDonnell & Miller electric water feeder.

**NOTE:** Connect hot wire to terminal marked (2) ahead of all controls. See diagram 1 on the following page (page 6) for control operation. See diagrams 2-4 on the following page (page 6) for proper application wiring.

**Diagram 1**

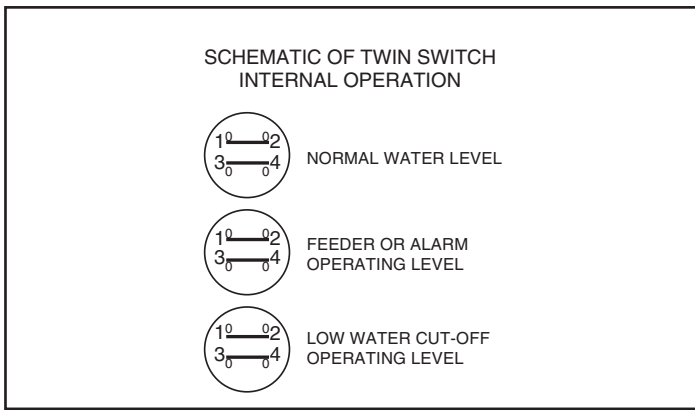

**Diagram 2**

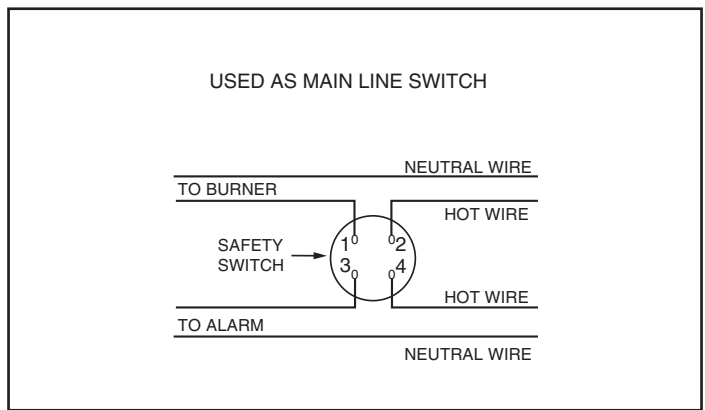

**Diagram 3**

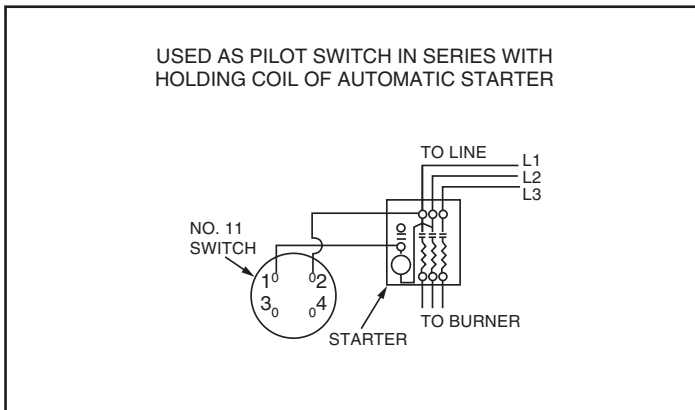

**Diagram 4**

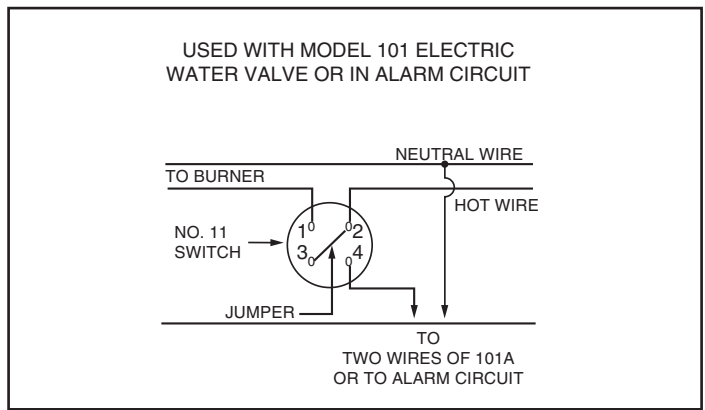

**IMPORTANT:** Low water cut-off circuit of the 61 series must be electrically wired in series with all other boiler limit operating controls.

## TROUBLESHOOTING

Problem:

**1. Burner does not shut off on low water.**

- a. **Cause:** Float chamber is loaded with mud or sediment.
 

**Test:** With water level below the control check if terminals 1 and 2 are open. If not, remove switch and manually test if terminals 1 and 2 can be opened.

**Solution:** Open float chamber and clean. At this time, check for a build-up of scale or sediment between corrugations of the bellows.
- b. **Cause:** Contacts are fused together.
 

**Test:** Remove switch and operate manually to verify proper switch operation.

**Solution:** Replace switch. Check electrical load and make sure it is within the ratings of the switch.

**2. Electric water feeder does not shut off.**

- a. **Cause:** Build-up of scale or sediment between corrugations of the bellows.
 

**Test:** With water level above the control, check if terminals 3 and 4 are open. If not, remove switch and manually test to verify terminals 3 and 4 can be opened.

**Solution:** Open float chamber and replace or clean the bellows.
- b. **Cause:** Contacts are fused together.
 

**Test:** Remove switch and operate manually to verify proper switch operation.

**Solution:** Replace switch. Check electrical load and make sure it is within the ratings of the switch.

# MAINTENANCE

## SCHEDULE:

- Blow down control as follows when boiler is in operation:

### Steam

- Daily if operating pressure is above 15 psi.
- Weekly if operating pressure is below 15 psi.

### Hot Water

- Quarterly

NOTE
More frequent blow-down may be necessary due to dirty water and/or local codes.

- **Disassemble and inspect annually. Replace the low water cut-off if it is worn, corroded, or if components no longer operate properly.**
- **Inspect the float chamber and equalizing piping annually. Remove all sediment and debris.**
- **Replace head mechanism every 5 years.**  
More frequent replacement may be required when severe conditions exist such as rapid switch cycling, surging water levels, and use of water treatment chemicals.
- **We recommend head mechanism replacement when the switch(es) no longer operate properly.**  
If you choose to replace the switch(es), order the proper McDonnell & Miller replacement switch or switch assembly and follow the Repair Procedure provided.

## PROCEDURE:

⚠ CAUTION	
	<p>To prevent serious personal injury from steam pipe blow down, connect a drain pipe to the control opening to avoid exposure to steam discharge.</p> <p>Failure to follow this caution could cause personal injury.</p>

1. Blow down the low water cut-off when the water level is at its normal level and the burner is on. **Slowly** open the blow-down valve until it is fully open and observe the water level fall in the gauge glass. Close the valve after verifying that the pump contacts have closed and the burner shuts off. If this does not happen, immediately shut off the boiler and correct the problem.