

Series 64

Low Water Cut-Off

Typical Applications:

- Primary or secondary low water cut-off for hot water and steam boilers.
- Low water cut-off
- High water cut-off
- Alarm actuator

OPERATION

Maximum Boiler Pressure: 50 psi (3.5 kg/cm²)

Electrical Ratings

Voltage	Motor Switch Rating (Amperes)		Pilot Duty
	Full Load	Locked Rotor	
120 VAC	7.4	44.4	125 VA at 120 or 240 VAC
240 VAC	3.7	22.2	

NOTE: 11MV is rated 24VA @ 24VAC to 120VAC.

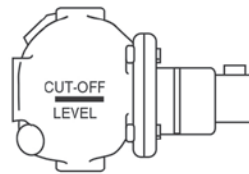

Model 64

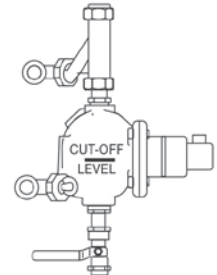

Model 64-A

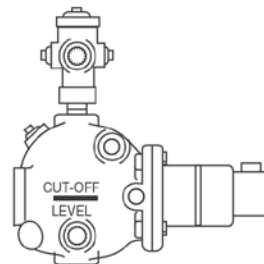



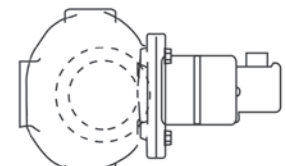

Model 64-CB



Model 764



WARNING

	<ul style="list-style-type: none"> • Before using this product read and understand instructions. • Save these instructions for future reference. • All work must be performed by qualified personnel trained in the proper application, installation, and maintenance of plumbing, steam, and electrical and/or systems in accordance with all applicable codes and ordinances.
	<ul style="list-style-type: none"> • To prevent serious burns, the boiler must be cooled to 80°F (27°C) and the pressure must be 0 psi (0 bar) before servicing. • To prevent electrical shock, turn off the electrical power before making electrical connections. • This low water cut-off must be installed in series with all other limit and operating controls installed on the boiler. After installation, check for proper operation of all of the limit and operating controls, before leaving the site.
	<ul style="list-style-type: none"> • We recommend that secondary (redundant) Low Water Cut-Off controls be installed on all steam boilers with heat input greater than 400,000 BTU/hour or operating above 15 psi of steam pressure. At least two controls should be connected in series with the burner control circuit to provide safety redundancy protection should the boiler experience a low water condition. Moreover, at each annual outage, the low water cut-offs should be dismantled, inspected, cleaned, and checked for proper calibration and performance.
	<ul style="list-style-type: none"> • To prevent serious personal injury from steam blow down, connect a drain pipe to the control opening to avoid exposure to steam discharge. • To prevent a fire, do not use this low water cut-off to switch currents over 7.4A, 1/3 HP at 120 VAC or 3.7A, 1/3 HP at 240 VAC, unless a starter or relay is used in conjunction with it. • This product can expose you to chemicals including Lead, which is known to the State of California to cause cancer and birth defects or other reproductive harm. For more information go to: www.P65Warnings.ca.gov. • Previous controls should never be installed on a new system. Always install new controls on a new boiler or system.
	<p>Failure to follow this warning could cause property damage, personal injury or death.</p> <p>CAUTION:</p> <ul style="list-style-type: none"> • A more frequent replacement interval may be necessary based on the condition of the unit at time of inspection. McDonnell & Miller's warranty is one (1) year from date of installation or two (2) years from the date of manufacture.

INSTALLATION –

Model 64 – For Steam Boilers with 1” (25mm) Equalizing Lines

TOOLS NEEDED:

One (1) flathead screwdriver and two (2) pipe wrenches.

STEP 1 - Determine the Location of the Low Water Cut-Off

- a. Whether the gauge glass is mounted directly into the boiler or on an independent water column, the cut-off line on the 64 body casting should be mounted 1/2" (15mm) above the lowest visible point of the gauge glass.

STEP 2 - Installation of the Model 64

- a. Locate the gauge glass and determine the level that the 64 has to be mounted at in order to achieve the criteria in Step 1.
- b. Pipe the 64 following the diagrams shown to the right. Follow the diagram that represents your boiler.
- c. Crosses should be used at each right angle connection for inspection and cleaning.
- d. Make sure the blow-down valves are full port.

Gauge Glass Mounted Directly into Boiler

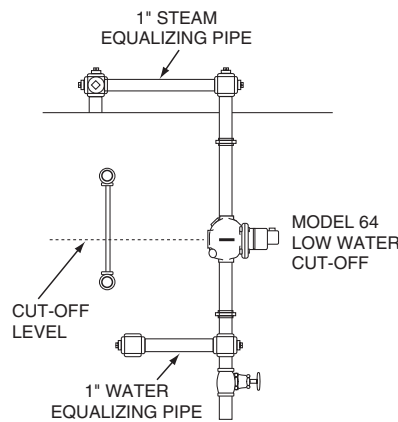

For Boilers with Independent Water Columns

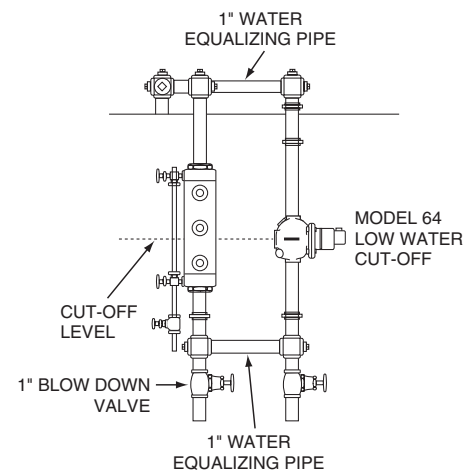

Test the Model 64 Before Leaving the Site

Open the blow-down valve, causing the water level to drop in the float chamber while burner is operating. As the float drops the alarm circuit (if used) closes first; then on further drop the cut-off circuit will open, shutting the burner off.

IMPORTANT: Instruct boiler attendant to blow down the float chamber at least once a week during the heating season, if operating pressure is below 15 psi (1 kg/cm²). If above 15 psi blow down once a day.

NOTE: On new boiler installations, leaky systems, or where the quality of the water is poor, blow down the control more frequently.

CAUTION

Protect yourself when blowing down controls, hot water and steam will flow out of the drain pipe attached to the blow-down valve. Failure to follow this caution may result in serious burns.

INSTALLATION –

Model 64 – For Hot Water Boilers with 1" (25mm) Equalizing Lines

TOOLS NEEDED:

One (1) flathead screwdriver and two (2) pipe wrenches.

STEP 1 - Determine the Location of the Low Water Cut-Off

- a. The line on the casting of the model 64 must be installed above the lowest permissible water level determined by the boiler manufacturer.

STEP 2 - Installation of the Model 64

For float type controls it is recommended that Test-N-Check® (TC-4) valves be used in the upper and lower equalizing lines. They offer a functional means for testing the 64 control, and conform to the ASME CSD-1 code.

- a. Study the figures to the right and determine which figure shows how the 64 control will be attached to the boiler.

Figure 1. Connect the upper equalizing pipe to the riser going to the radiation or to the compression tank. Connect the lower equalizing pipe to any available opening in the side of the boiler. **NOTE:** If no opening is available in the side of the boiler, connect the lower equalizing pipe into the drain connection.

Figure 2. If there is a tapping available on the top of the boiler connect the upper equalizing pipe to it. **NOTE:** During initial filling or after blow down the upper equalizing pipe and possibly the 64 control will have an air pocket. Connect a vent or bleed valve on the top of the vertical equalizing pipe. If the Test-N-Check (TC-4) valve is used the vacuum breaker can be used to bleed the air pocket.

CAUTION: When bleeding an air pocket manually, protect yourself from being burned with hot water.

Figure 3. If there is no tapping available on the boiler, connect both the upper and lower equalizing pipe into the vertical riser going to the radiation or to the compression tank. **IMPORTANT:** The horizontal equalizing pipe should not be above the horizontal run going to the radiation. If it is, an air pocket will be created and a vent or bleed will have to be installed.

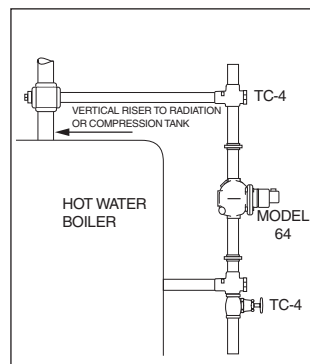

Figure 1

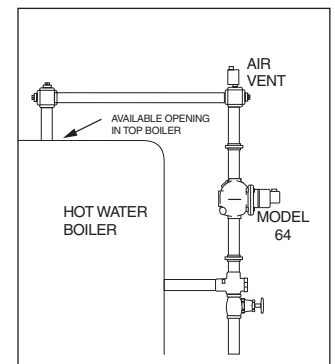

Figure 2

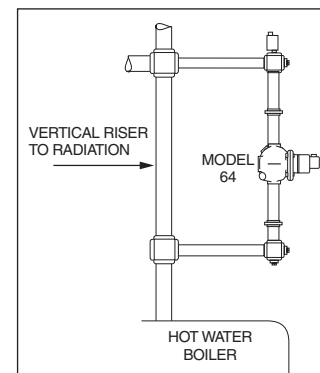

Figure 3

Test the Model 64 Before Leaving the Site

While the burner is operating open the blow-down valve, causing the water level to drop in the float chamber. As the float drops the alarm circuit (if used) closes first; then on further drop the cut-off circuit will open, shutting the burner off. **NOTE:** If no Test-N-Checks (TC-4) valves were used, do this test before filling the system completely.

IMPORTANT: Instruct boiler attendant to blow down the float chamber at least once a week during the heating season, if operating pressure is below 15 psi (1 kg/cm²). If above 15 psi blow down once a day.

NOTE: On a new boiler installation, leaky system, or where the quality of the water is poor, blow down the control more frequently.

CAUTION

Protect yourself when blowing down controls, hot water will flow out of the drain pipe attached to the blow-down valve. Failure to follow this caution may result in serious burns.

INSTALLATION –

Model 764 – For Steam or Hot Water Boilers

TOOLS NEEDED:

One (1) flathead screwdriver and two (2) pipe wrenches.

STEP 1 - For Steam or Hot Water Boilers where 2 1/2" (65mm) Tapping is Provided

- a. See figure 1. The 2 1/2" (65mm) tapping on the boiler has to be above the minimum safe operating level, as determined by the boiler manufacturer. On steam boilers, make sure the line on the casting is above the lower gauge glass nut. **NOTE:** Do **not** reduce the 2 1/2" (65mm) tapping, as this would compromise low water protection.

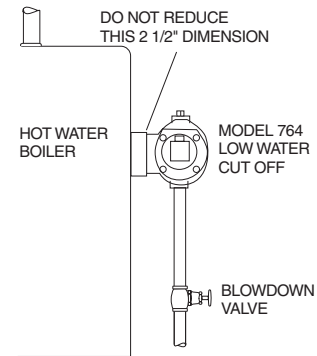

Figure 1

STEP 2 - For Hot Water Boilers where 2 1/2" (65mm) Tapping is not Provided

- a. See figure 2. If there are no 2 1/2" (65mm) tapings on a hot water boiler, the 764 control can be mounted on a 2 1/2" (65mm) tee on the riser going to the radiation or compression tank. **NOTE:** Do **not** reduce the 2 1/2" (65mm) tapping, as this would compromise low water protection.

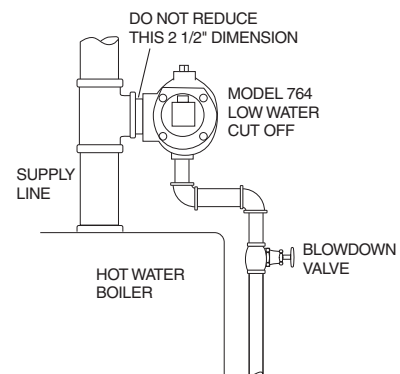

Figure 2

Test the Model 764 Before Leaving the Site

While the burner is operating open the blow-down valve, causing the water level to drop in the float chamber. As the float drops the alarm circuit (if used) closes first; then on further drop the cut-off circuit will open, shutting the burner off. **NOTE:** If no Test-N-Checks (TC-4) valves were used, do this test before filling the system completely.

IMPORTANT: Instruct boiler attendant to blow down the float chamber at least once a week during the heating season, if operating pressure is below 15 psi (1 kg/cm²). If above 15 psi blow down once a day.

NOTE: On a new boiler installation, leaky system, or where the quality of the water is poor, blow down the control more frequently.

CAUTION

Protect yourself when blowing down controls, hot water will flow out of the drain pipe attached to the blow-down valve. Failure to follow this caution may result in serious burns.

INSTALLATION –

Model 64-A – For Steam Boilers Using Quick Hook-up Fittings

TOOLS NEEDED:

One (1) flathead screwdriver, two (2) pipe wrenches, and an adjustable wrench.

STEP 1 - Preparing the Boiler

- a. Remove gauge glass and its trim from the boiler.

STEP 2 - Installation of the Model 64-A

- a. See figures 1 and 2. Install both brass Y fittings (A) into the boiler gauge glass tapings.

NOTE: If gauge glass tapings are spaced more than 10 1/8" (270mm) apart, invert the Black Y (B). See figure 2. If spaced greater than 13 3/8" (339mm), substitute a longer 1/2" (15mm) nipple for original (C).

- b. See figure 3. Install reducing bushing (D) and nipple (C) into top 1" (25mm) NPT tapping (E). Install reducing bushing (F), nipple (G), and blow down valve (H) into 1" (25mm) NPT (J).

- c. See figure 3. Slip union nut (K) over lower tail piece (L) and screw it into either 1/2" (15mm) tapping (M) or (N). Use the 1/2" (15mm) pipe plug to close unused tapping. Slip union nut (O) over union piece (P) and nipple (R) and install into black Y (B). Slide black Y (B) over nipple (C). Connect upper (O) and lower (K) unions to brass Y fitting (A, figure 1) and tighten. **NOTE:** the black Y (B) will have to be moved up or down to mate the union halves. Tighten compression nut (S).

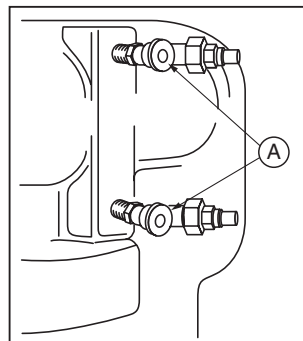

Figure 1

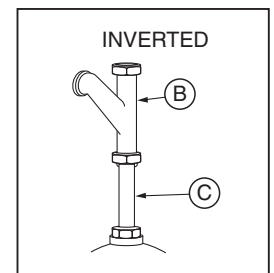

Figure 2

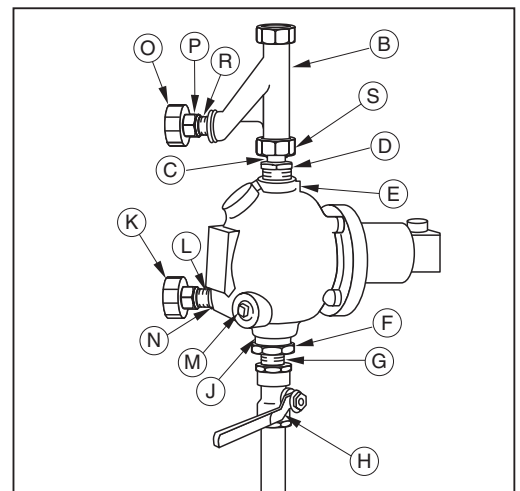

Figure 3

Test the Model 64-A Before Leaving the Site

While the burner is operating open the blow-down valve, causing the water level to drop in the float chamber. As the float drops the alarm circuit (if used) closes first; then on further drop the cut-off circuit will open, shutting the burner off. **NOTE:** If no Test-N-Checks (TC-4) valves were used, do this test before filling the system completely.

IMPORTANT: Instruct boiler attendant to blow down the float chamber at least once a week during the heating season, if operating pressure is below 15 psi (1 kg/cm²). If above 15 psi blow down once a day.

NOTE: On a new boiler installation, leaky system, or where the quality of the water is poor, blow down the control more frequently.

CAUTION

Protect yourself when blowing down controls, hot water will flow out of the drain pipe attached to the blow-down valve. Failure to follow this caution may result in serious burns.

Wiring Instructions

WARNING



- To prevent electrical shock, turn off the electrical power before making electrical connections.
- This low water cut-off must be installed in series with all other limit and operating controls installed on the boiler. After installation, check for proper operation of all of the limit and operating controls, before leaving the site.



Failure to follow this warning could cause electrical shock, an explosion and/or a fire, which could result in property damage, personal injury or death.

Using a flathead screwdriver, remove the one (1) screw that secures the switch cover.

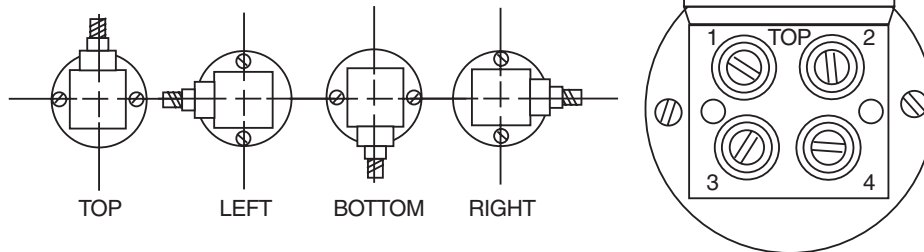
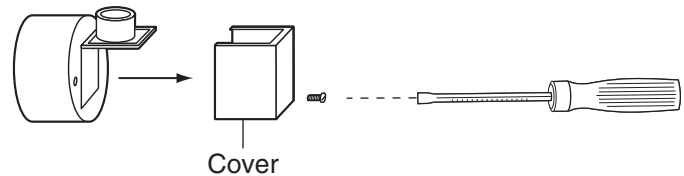

Electrical connector is movable into any one of four positions illustrated, by simply removing two black headed screws and rotating housing.

NOTE: This control should be wired with materials suitable for use at 75°C.

Switch Operation

The No. 11 switch can be identified by a black terminal panel. The switch contains two (2) single pole single throw switches to control the water feeder and the low water cut-off. The low water cut-off switch is between terminals marked "1" and "2". A second switch is located between terminals marked "3" and "4". This can be used to operate a low water alarm or a McDonnell & Miller electric water feeder.

NOTE: Connect hot wire to terminal marked (2) ahead of all controls. See diagram 1 on the following page (page 7) for control operation. See diagrams 2-4 on the following page (page 7) for proper application wiring.

Diagram 1

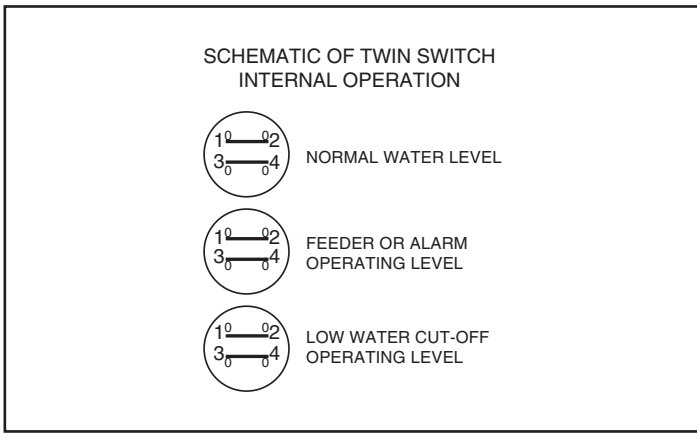

Diagram 2

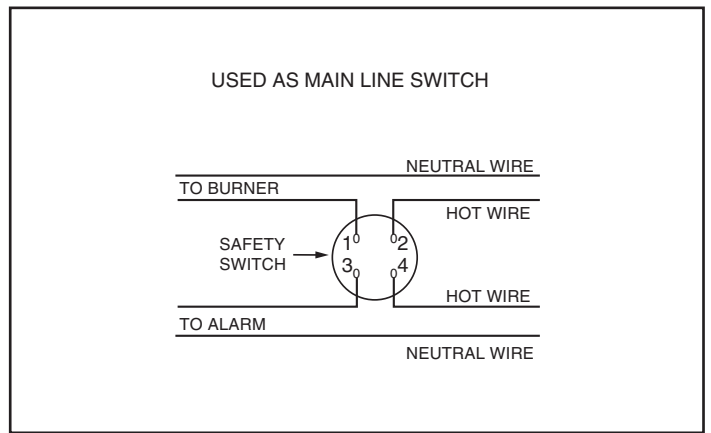
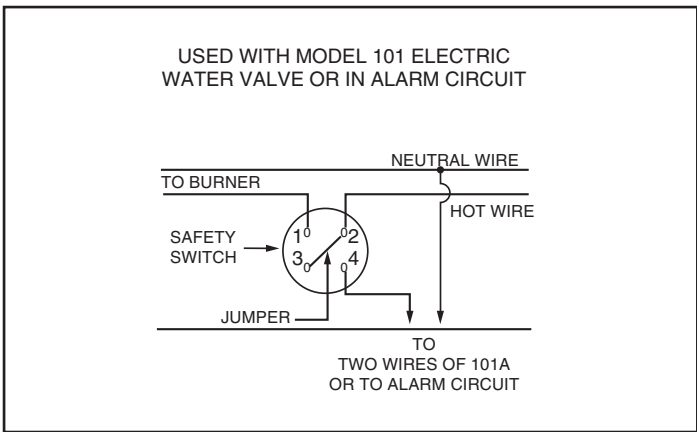

Diagram 3



IMPORTANT: Low water cut-off circuit of the 64 series must be electrically wired in series with all other boiler limit operating controls.

Model 64A-M For use on 24 or 120 VAC systems requiring manual reset on low water cut-off.

CAUTION

Do not electrically connect water feeder to Model 64A-M. This model includes a manual reset feature, failure to follow this caution could result in boiler flooding and property damage.

WIRING SCHEMATIC

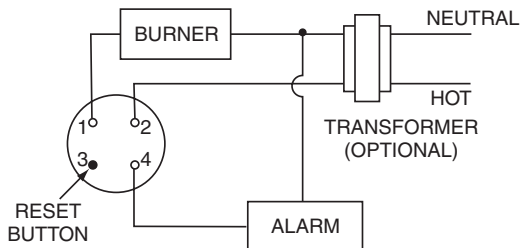

SWITCH SCHEMATIC

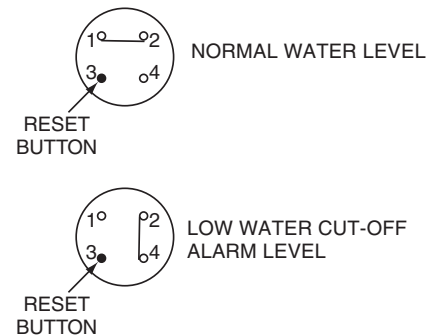

Place the cover on the switch housing and, using a flathead screwdriver, tighten the one (1) screw to approximately 2 ft•lb (2.6 N•m).

