

Series 67 and 767 Low Water Cut-Offs For Steam Boilers

Applications:

For residential and commercial boilers of any steaming capacity.

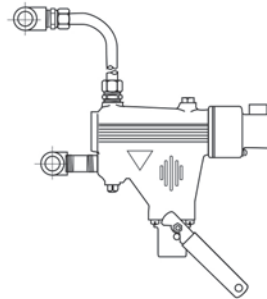



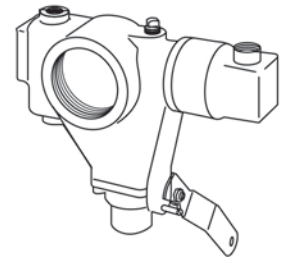

Series 67



Series 767



WARNING

	<ul style="list-style-type: none"> • Before using this product read and understand instructions. • Save these instructions for future reference.
	<ul style="list-style-type: none"> • All work must be performed by qualified personnel trained in the proper application, installation, and maintenance of plumbing, steam, and electrical and/or systems in accordance with all applicable codes and ordinances. • To prevent electrical shock, turn off the electrical power before making electrical connections.
	<ul style="list-style-type: none"> • This low water cut-off must be installed in series with all other limit and operating controls installed on the boiler. After installation, check for proper operation of all of the limit and operating controls, before leaving the site. • We recommend that secondary (redundant) Low Water Cut-Off controls be installed on all steam boilers with heat input greater than 400,000 BTU/hour or operating above 15 psi of steam pressure. At least two controls should be connected in series with the burner control circuit to provide safety redundancy protection should the boiler experience a low water condition. Moreover, at each annual outage, the low water cut-offs should be dismantled, inspected, cleaned, and checked for proper calibration and performance.
	<ul style="list-style-type: none"> • To prevent serious personal injury from steam and hot water make sure there is a discharge line from the blow down valve to a proper place of disposal. • To prevent a fire, do not use this low water cut-off to switch currents over 7.4A, 1/3 Hp at 120 VAC or 3.7A, 1/3 Hp at 240 VAC, unless a starter or relay is used in conjunction with it. • This product can expose you to chemicals including Lead, which is known to the State of California to cause cancer and birth defects or other reproductive harm. For more information go to: www.P65Warnings.ca.gov. • Previous controls should never be installed on a new system. Always install new controls on a new boiler or system.
	<p>Failure to follow this warning could cause property damage, personal injury or death.</p> <p>CAUTION:</p> <ul style="list-style-type: none"> • A more frequent replacement interval may be necessary based on the condition of the unit at time of inspection. McDonnell & Miller's warranty is one (1) year from date of installation or two (2) years from the date of manufacture.

OPERATION

Maximum Steam Pressure: 20 psi (1.4 kg/cm²)

Electrical Ratings

Voltage	Pump Circuit Rating (Amperes)		Pilot Duty
	Full Load	Locked Rotor	
120 VAC	7.4	44.4	125 VA at
240 VAC	3.7	22.2	120 or 240 VAC

Note: 11 MV is rated at 24 VA @ 24 VAC to 120 VAC

The Series 67 and Series 767 low water cut-offs are float-type boiler controls designed to interrupt current to the burner whenever the water drops to the cut-off level.

The Series 767 is identical to Series 67 in all respects except one. The Series 767 is equipped with

a 2-1/2" (63.5mm) pipe tap opening in the body, and does not require the quick hook-up fittings supplied with the Series 67. The pipe tapping allows for a direct connection to the side of the boiler.

INSTALLATION –

TOOLS NEEDED:

One (1) tube cutter, one (1) pencil, one (1) flathead screwdriver, one (1) adjustable wrench and two (2) pipe wrenches.

IMPORTANT: Follow the boiler manufacturer's instructions along with all applicable codes and ordinances for piping, blow down valve and water gauge glass installation.

STEP 1 - Determine the Elevation at Which the Low Water Cut-Off Controller Must be Installed

For Series 67 - The elevation of the control (A) is already determined by the location of the gauge glass tapplings (B,C) on the boiler. The horizontal cast line (D) should be located at or above the boiler manufacturer's minimum safe water level (E).

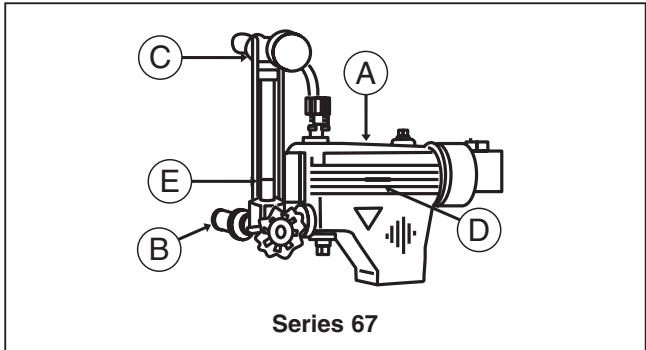

For Series 767 - The elevation of the control (A) is already determined by the location of the 2-1/2" (63.5mm) pipe tapping on the boiler. The horizontal cast line (D) of the body (A) should be located at or above the boiler manufacturer's minimum safe water level.

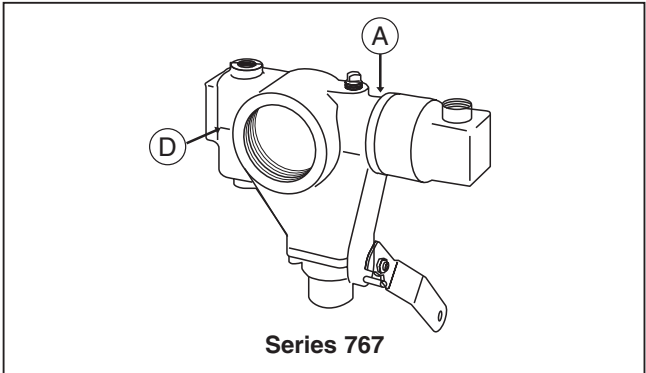

STEP 2 - Preparation

- a. Turn the boiler off.

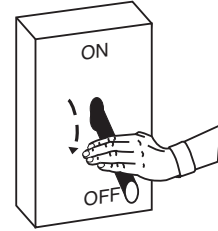

- b. Drain the water in the boiler to a level which is below the lower gauge glass tapping (B) of the control body (A). Allow the boiler to cool to 80°F (27°C) and allow the pressure to release to 0 psi (0 bar).

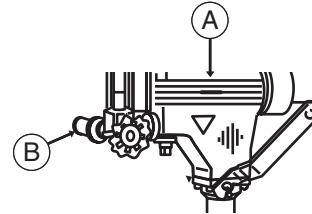

CAUTION



When using the tape sealant on the external threads of pipes or fittings, follow the manufacturers instructions. Use sparingly and do not place on the first thread.

STEP 3 - Installing the New Low Water Cut-Off

- a. Using a pipe wrench, remove the float blocking tube (F) from the new control and tighten a 1/2" (13mm) NPT pipe plug (G) (provided) into the tapping on the bottom of the control body (A). Tighten the pipe plug to 31 ft•lb (42 N•m).

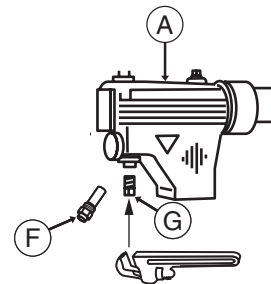

- b. Using a pipe wrench, install a 1/2" (13mm) nipple (H) into the lower gauge glass tapping (B) and pipe tee assembly (J). Tighten both connections to 31 ft•lb (42 N•m).

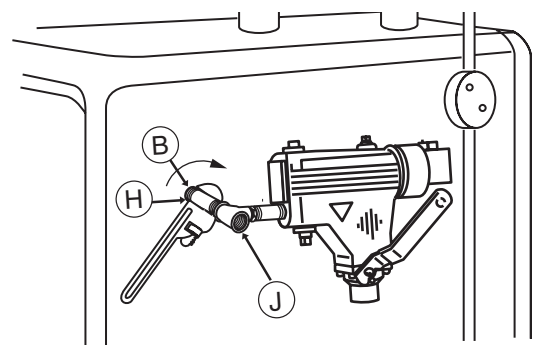

- c. Using an adjustable wrench, install a $\frac{3}{8}$ " (9.5mm) NPT compression fitting base (K) to the upper tapping (L) in the control (A). Tighten to 31 ft•lb (42 N•m).

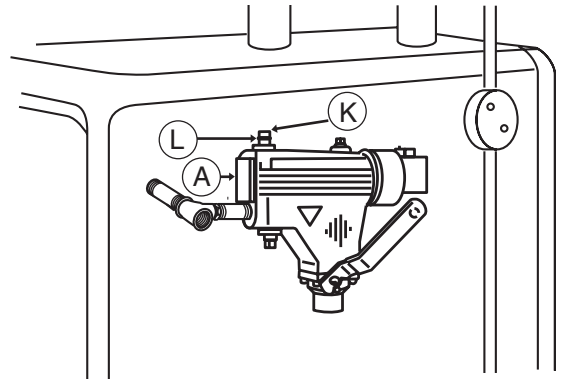

- d. Using a pipe wrench, install a $\frac{1}{2}$ " (13mm) nipple (M) into the upper tapping (N). Tighten to 31 ft•lb (42 N•m).

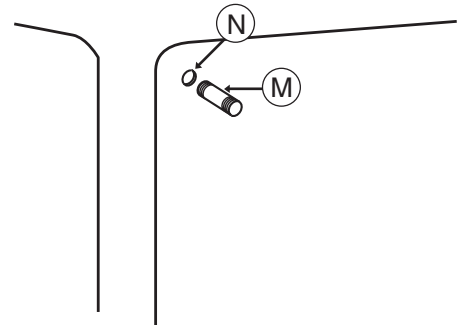

- e. Using a pipe wrench, install the pipe tee (P) onto the nipple (M) in the upper tapping (N). Tighten to 31 ft•lb (42 N•m).

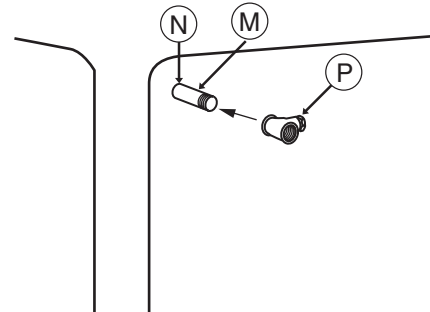

- f. Using an adjustable wrench, install $\frac{1}{2}$ (13mm) NPT compression fitting base (U) into the upper tee (P). Tighten to 31 ft•lb (42 N•m). Place the compression nut (R) and compression ring (S) over the top of tubing (Q). Insert tubing (Q) into compression base (U). Turn compression nut (R) hand tight. DO NOT TIGHTEN.

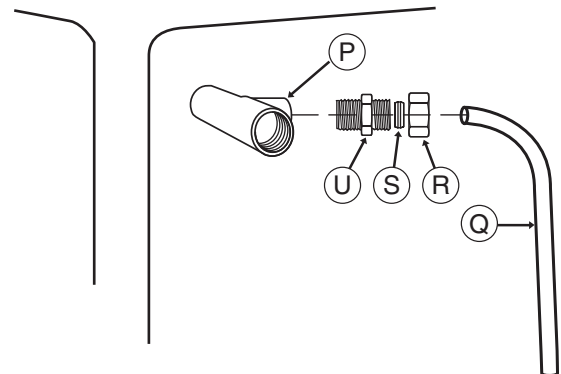

IMPORTANT: Do not use tape or pipe sealant on the compression fittings.

- g.** Position the tubing (Q) next to the compression fitting (K) and, using a pencil, mark the tubing (Q) for proper insertion into the compression fitting (K).

Remove the tubing (Q), and, using the tube cutter, cut the tubing to its proper length.

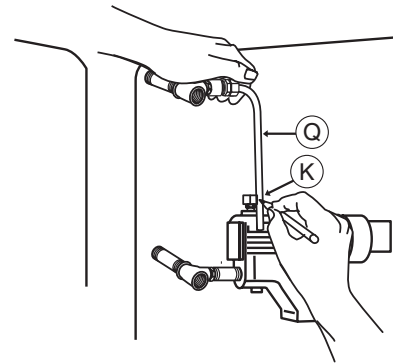

- h.** Insert the tubing (Q) into the upper compression fitting (U) and tighten the fitting to 31 ft•lb (42 N•m).

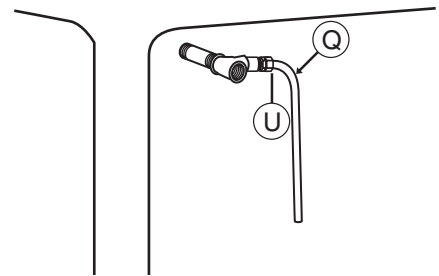

- i.** Using two (2) pipe wrenches, rotate the upper tee (P) counterclockwise and the lower tee (J) clockwise.

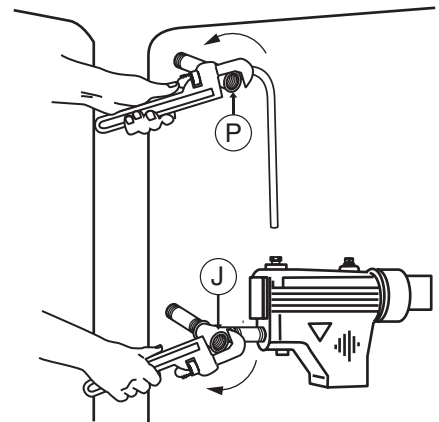

- j.** Place the compression nut (R) and the compression ring (S) over the bottom of the tubing (Q).

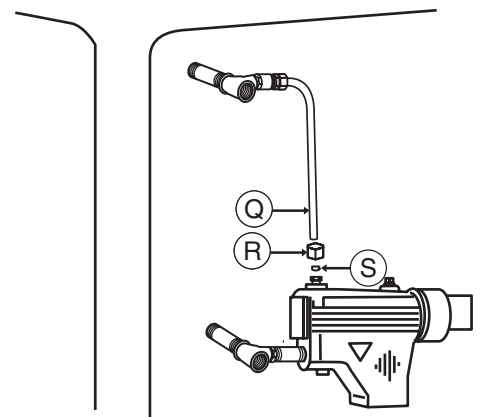

k. Using two (2) pipe wrenches, rotate the upper tee (P) clockwise and the lower tee (J) counter-clockwise so that the end of the tube can be inserted into the lower compression fitting (K). NOTE: Make sure that the control is in a horizontal position. Using an adjustable wrench, tighten the lower compression fitting (K) to 31 ft•lb (42 N•m).

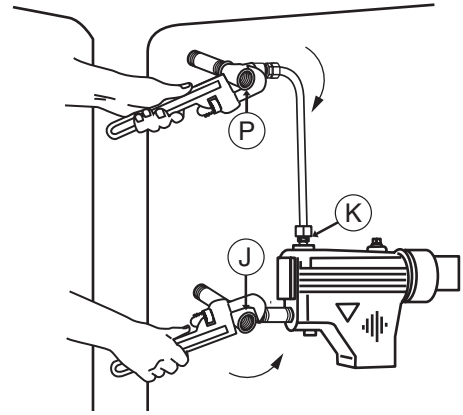

l. Using a pipe wrench, install a 3/4" (19mm) NPT pipe (T) into the opening of the blow down valve (U) and tighten to 47 ft•lb (64 N•m).

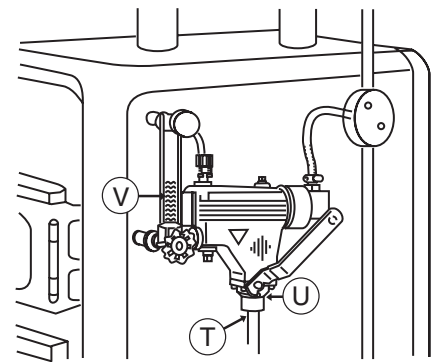

CAUTION



To prevent burning or scalding, pipe blow-off discharge from blow-down valve to floor – allowing enough height for a pail under discharge pipe to collect blow down discharge. This pipe must be same 3/4" size as blow-down connection; do not reduce. Do not thread end of pipe.

m. Hang the blow down card (W) (enclosed) as close to the control (A) as possible, or remove the protective backing and affix the card on the boiler jacket close to the control.

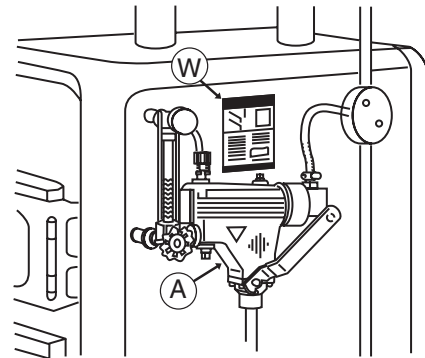

For Series 767

a. Using a pipe wrench, install a 2 1/2" (63.5mm) nipple (X) into the side of the boiler. Tighten to 109 ft•lb (148 N•m).

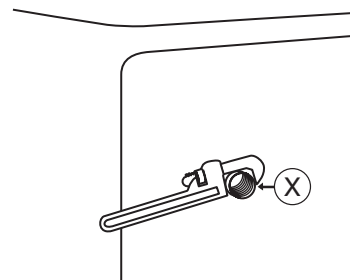

- b. Install the control (A) by rotating it onto the 2½" (63.5mm) nipple (X, as shown in Step a on previous page). Tighten to 109 ft•lb (148 N•m).

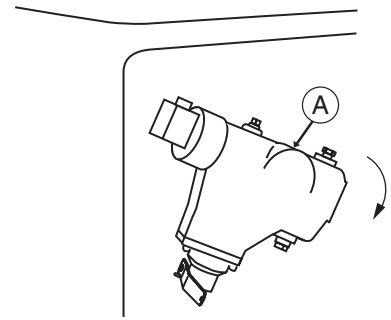

- c. Using a pipe wrench, install a ¾" (19mm) NPT pipe (T) into the opening of the blow down valve (U) and tighten to 47 ft•lb (64 N•m).

CAUTION



To prevent burning or scalding, pipe blow-off discharge from blow-down valve to floor – allowing enough height for a pail under discharge pipe to collect blow down discharge. This pipe must be same ¾" size as blow-down connection; do not reduce. Do not thread end of pipe.

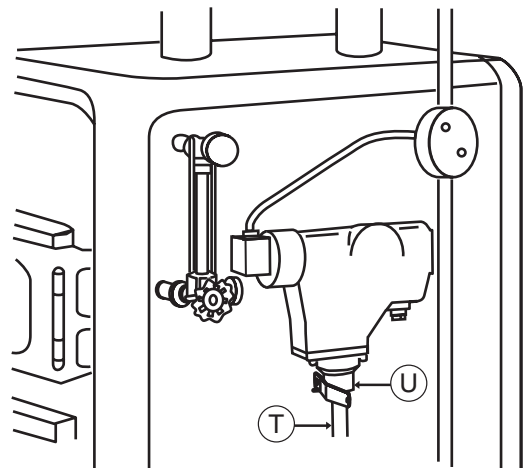

- d. Hang a blow down card (W) (enclosed) as close to the control (A) as possible, or remove the protective backing and affix the card on the boiler jacket close to the control.

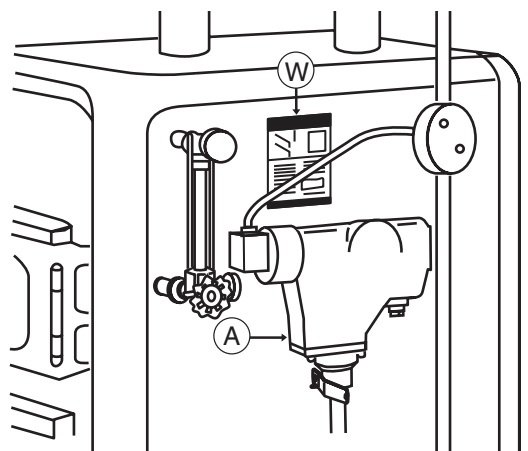

STEP 4 - Electrical Wiring

Directory: 67 Low Water Cut-Off and Uni-Match Water Feeder page 8 - 9
67 Low Water Cut-Off and 101 Water Feeder page 10 - 11

For 67 Low Water Cut-Off Installed with McDonnell & Miller Uni-Match Water-Feeder

WARNING



- To prevent electrical shock, turn off the electrical power before making electrical connections.
- This low water cut-off must be installed in series with all other limit and operating controls installed on the boiler. After installation, check for proper operation of all of the limit and operating controls, before leaving the site.



Failure to follow this warning could cause electrical shock, an explosion and/or a fire, which could result in property damage, personal injury or death.

- a. Using a flathead screwdriver, remove the one (1) screw that secures the low water cut-off switch cover (Y).

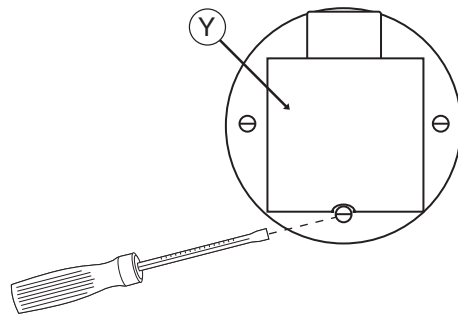

- b. Using a flathead screwdriver, loosen the two (2) screws and remove the feeder cover (Z).

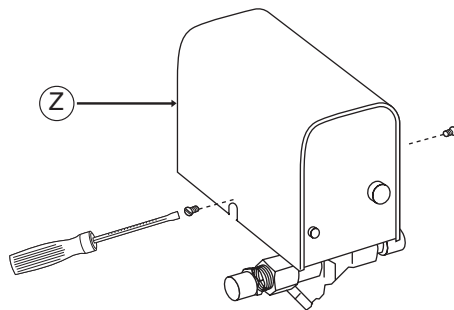

- c. Position the slide switch selector (AA) in the #1 position.

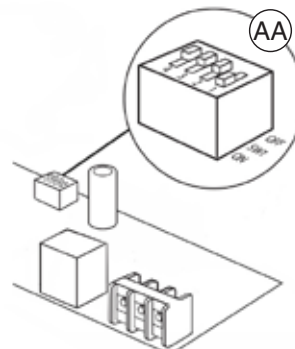

NOTE: To connect wires to the terminals on the water feeder, burner, or low water cut-off, place the bare end of the wire under the terminal screw and tighten the screw with a flathead screwdriver.



For the 120V Burner/120V Feeder or the 24V Burner/24V Feeder setups.

d. Connect a wire from the "hot" side of the power supply to the water feeder terminal #3, and low water cut-off terminal #2. Connect a wire from the neutral side of the power supply to the water feeder terminal #2, and to the neutral side of burner.

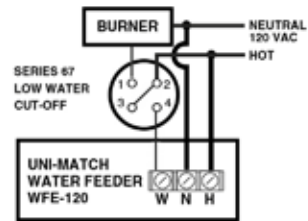

e. Connect the wire from the burner to terminal #1 of the low water cut-off. Connect a "jumper" from terminal #2 to terminal #3 of the low water cut-off. Connect a wire from terminal #4 of the low water cut-off to terminal #1 of the water feeder.

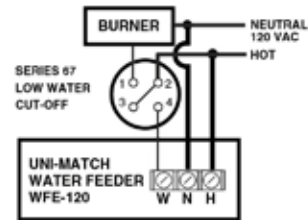

Wiring Alternative

For the 24V Burner/120V Feeder setups.

For the 120V Burner/24V Feeder setups.

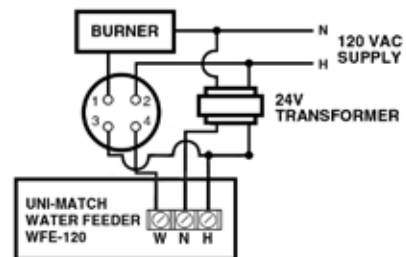
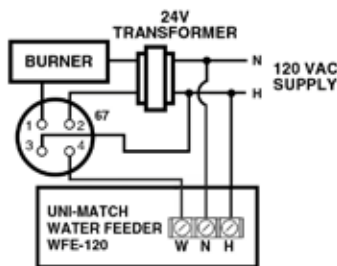

For 67 Low Water Cut-Off Installed with McDonnell & Miller Series 101-A Water-Feeder

- a. Using a flathead screwdriver, remove the one (1) screw that secures the low water cut-offs switch housing (Y).

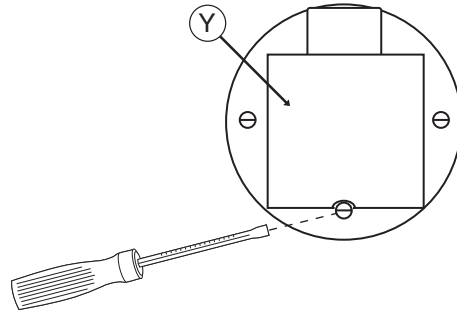

- b. Using a flathead screwdriver, remove the two (2) screws that secure the feeder cover (BB).

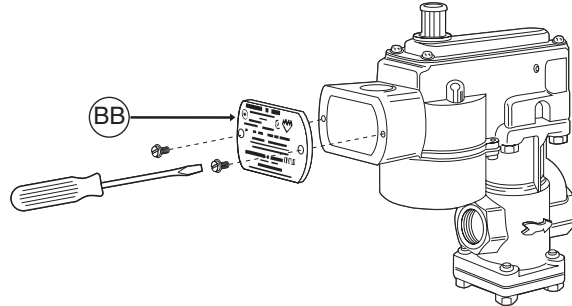

NOTE: To connect wires to the terminals on the burner, or low water cut-off, place the bare end of the wire under the terminal screw and tighten the screw with a flat-head screwdriver. On the 101-A water feeder use wire nuts.

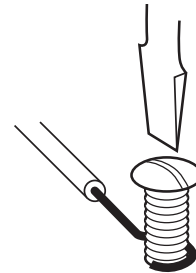

For the 120V Burner/120V Feeder setups.

- c. Using a wire nut, connect a wire from the neutral side of the power supply to one of the wires inside the feeders junction box. (Does not make a difference which one). Connect a wire from the "hot" side of the power supply to terminal #2 of the Series 67 junction box. Connect the neutral side of the power supply to the burner.

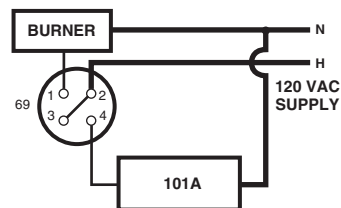

- d. Connect the wire from the burner to terminal #1 of the low water cut-off. Connect a "jumper" from terminal #2 to terminal #3 of the low water cut-off. Connect a wire from terminal #4 of the low water cut-off to the remaining wire in the 101A water feeder.

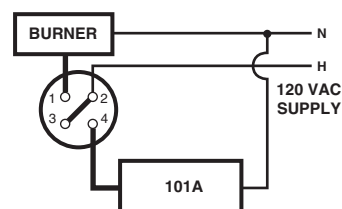

For the 24V Burner/24V Feeder setups.

- c. Connect the "hot" wire from the boiler transformer to terminal #2 of the low water cut-off. Connect the "hot" side of the water feeder transformer to terminal #3 of the low water cut-off. Connect the neutral side of the boiler transformer to the burner. Using a wire nut, connect the neutral side of the water feeder transformer to the water feeder.

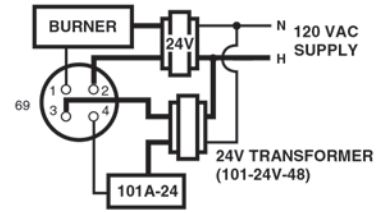

- d. Connect the wire from the burner to terminal #1 of the low water cut-off. Connect a wire from terminal #4 of the low water cut-off to the remaining wire in the water feeder. Wire nut together.

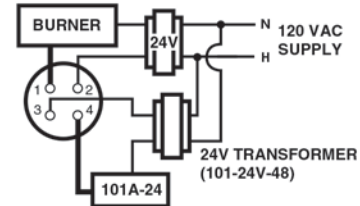

Wiring Alternative

For the 120V Burner/24V Feeder setups.

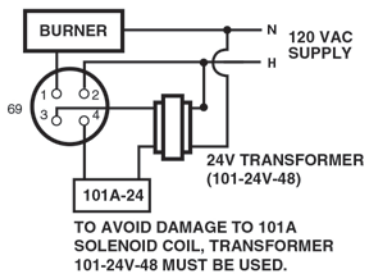

For the 24V Burner/120V Feeder setups.

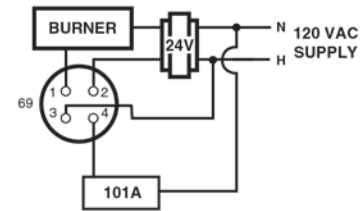

IMPORTANT: It is very important that you use the transformer supplied with the 101-A-24. The boiler transformer in most cases is not big enough to handle the current draw of the 101-A-24. Use the supplied transformer (101-24V-48). In most cases it will handle both the boiler and feeder. **Do not try to use two transformers in the same circuit.**

For All Installations

The BX outlet (GG) on the control is movable into any of the four positions by simply removing the two black-headed screws and rotating the housing.

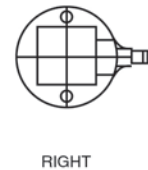
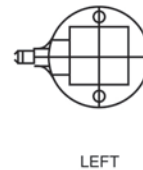
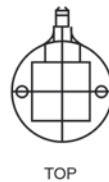
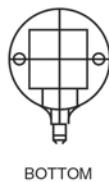
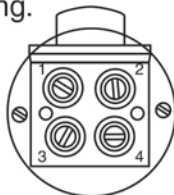

INSTALLATION COMPLETE