

## Series RS – Remote Sensors Series PA – Probe Assemblies & Probes for Liquid Level Controls

For use with all Electronic Level Controls  
Series 750, PCH/PCL, PS-800/850; LPC-2000,  
RB-120, RB-122

### Models RS-1-BR-1 & RS-1-HP

For High Pressure Steam & Conductive Liquid Systems

### Models RS-1-LP & RS-1-LPS

For Hydronic, Low Pressure Steam &  
Conductive Liquid Systems

### Series PA

For Hydronic, Low Pressure Steam &  
Conductive Liquid Systems

#### Applications:

- Primary conductance type control for commercial or industrial hot water boilers with remote or integral sensing provisions.
- Secondary control for commercial or industrial steam boilers.
- For tank, hydronic and general level sensing.

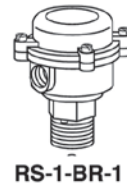

RS-1-BR-1

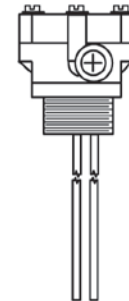

RS-2-BR-1

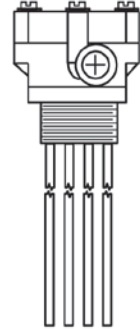

RS-4-BR-1

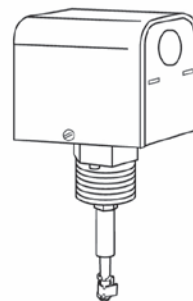

RS-1-LP

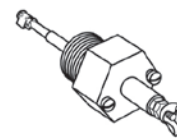

PA-800 &  
PA-RB-120

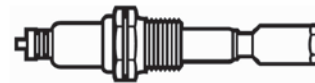

PA-750-HP



### **WARNING**



- Before using this product read and understand instructions.
  - Save these instructions for future reference.
  - All work must be performed by qualified personnel trained in the proper application, installation, and maintenance of plumbing, steam, and electrical and/or systems in accordance with all applicable codes and ordinances.
  - To prevent serious burns, the boiler must be cooled to 80°F (27°C) and the pressure must be 0 psi (0 bar) before servicing.
  - To prevent electrical shock, turn off the electrical power before making electrical connections.
  - This low water cut-off must be installed in series with all other limit and operating controls installed on the boiler. After installation, check for proper operation of all of the limit and operating controls, before leaving the site.
  - To prevent serious personal injury from steam blow down, connect a drain pipe to the control opening to avoid exposure to steam discharge.
  - To prevent a fire, do not exceed the switch contact rating.
  - This product can expose you to chemicals including Lead, which is known to the State of California to cause cancer and birth defects or other reproductive harm. For more information go to: [www.P65Warnings.ca.gov](http://www.P65Warnings.ca.gov).
  - Previous controls should never be installed on a new system. Always install new controls on a new boiler or system.
- Failure to follow this warning could cause property damage, personal injury or death.

#### **CAUTION:**

- A more frequent replacement interval may be necessary based on the condition of the unit at time of inspection. McDonnell & Miller's warranty is one (1) year from date of installation or two (2) years from the date of manufacture.

Sensor Model #	Connection / Material	Enclosure Type	Probe Rods Required	Spacer & Collar Required	Maximum Pressure	Maximum Temperature
All PA Series (ex. PA-750-HP)	3/4" NPT Brass Barstock (1/2" PA-800-RX2)	None	None	None	Steam: 15 PSIG (1kg/cm <sup>2</sup> ) Water 160 PSIG (11.2 kg/cm <sup>2</sup> )	250°F(121°C)
RS-1-LP RS-1-LPS	3/4" NPT Brass Barstock	NEMA 1				
PA-750-HP	3/8" NPTF Stainless Steel	None	1	None	Steam: 250 PSIG (17.6 kg/cm <sup>2</sup> ) or Water: 250 PSIG (17.6 kg/cm <sup>2</sup> )	406°F (208°C)
RS-1-HP	3/4" NPT Brass Barstock	NEMA 1	1	None		
RS-1-BR-1	1" NPT Brass Casting	NEMA 4X	1	None		
RS-2-BR-1 RS-3-BR-1	2" NPT Brass Casting	NEMA 4X	2 3	Yes if probes longer than 36" (909mm)		
RS-4-BR-1 RS-5-BR-1	2-1/2" NPT Brass Casting	NEMA 4X	4 5			

**SENSOR & PROBE ROD ASSEMBLY FOR RS-1-BR-1, RS-1-HP & PA-750-HP ONLY. FOR RS-1-LP AND SERIES PA ASSEMBLIES, PROCEED TO STEP 2 INSTALLATION**

Cut probes to desired length before assembly to the electrode. When trimming probe to desired length, place end to be cut off in a vise. If the cut is made in the black PTFE coated region of a 2 to 6 foot electrode, remove about 1/8 inch of black PTFE coating from the bottom of the electrode by scraping with a knife or file. Be careful not to damage the remaining black PTFE coating which serves as an insulation to prevent shorting between the probes.

If two or more probes are greater than 3 feet, a spacer must be used to keep adjacent probes separated. Slide a collar over the longest probe and position the set-screw so that it is inside the outside diameter of the spacer and securely tighten set-screw to lock collar in position about 3-1/2 feet from the remote sensor body. Then, slide the spacer over the probes separating the longer probes. Finally, on the same longest probe, slide another collar so that the set-screw is in the same direction as the first

collar to firmly position the spacer against the first collar so both collars and spacer are in a tight arrangement. Securely tighten set-screw of second collar.

After the above assemblies have been completed, mark the wire connectors on electrodes inside electrical enclosure appropriately so the correct length probe can be wired to the correct terminal in the control.

The material of the tank or vessel determines if an additional probe is required for grounding. Metal tanks do not require an additional probe because the tank can be used as the ground path needed to complete the current path. Plastic, concrete and lined metal tanks will require a ground probe for use to complete the current path. **It is highly recommended that a ground probe be added on all installations.** The less distance the current has to travel to complete the path the better the control operates, especially in liquids with high resistance.

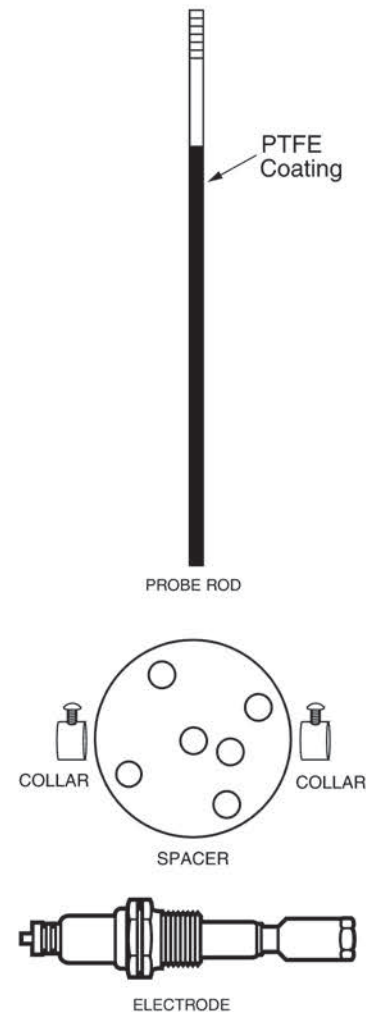

## STEP 1 - Where to Install the Remote Sensors

Determine where to install the remote sensor based on the following requirements:

- The tip of the probe or extension **must be installed above the minimum safe water level**, as determined by the boiler manufacturer.
- Probes must be installed vertically if they are more than 5" (127mm) long.
- Make sure that the ends and sides of the probe are at least 1/4" (6.4mm) from all internal metal surfaces. Make sure the probe is positioned to shut off the boiler before the water level falls below the lowest visible part of the gauge glass.

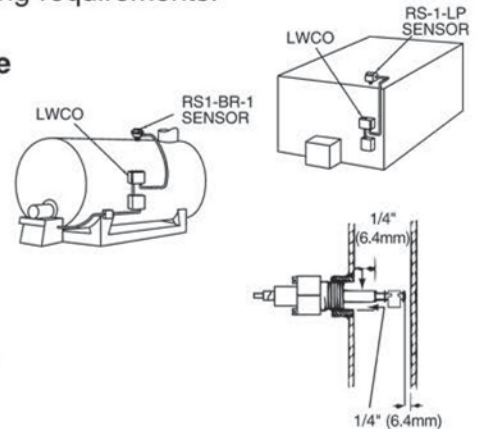

### For Hot Water Boilers

- Refer to the boiler manufacturer's instructions to determine suitable tapping for the probe.
- Locate probe in supply piping using tee fitting.

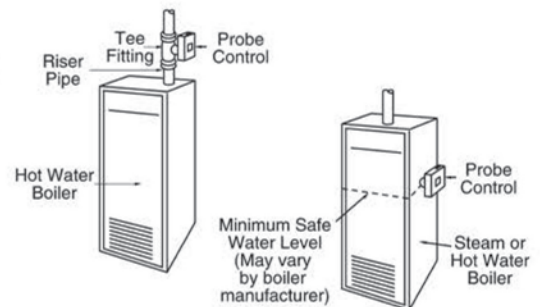

## STEP 2 - Installing the Remote Sensor

### For All Remote Sensors

- Apply a small amount of pipe dope to the first threads (A) of the remote sensor.

### **WARNING**

Do not use PTFE tape. Only use pipe sealant. Failure to follow these instructions will cause the probe not to function as intended and could cause property damage, personal injury or death.

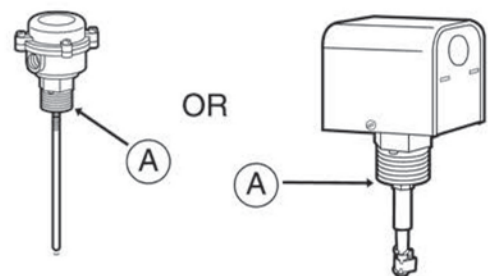

- Insert the sensor (B) into the boiler tapping (C) as determined in step 1.

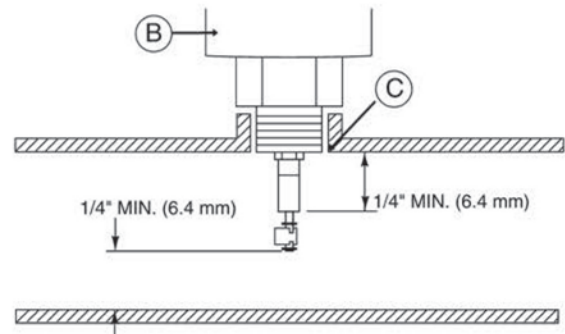

## STEP 2 - Installing the Remote Sensor (cont'd)

- c. Using a wrench (D), tighten the brass hex adapter (E) on the remote sensor (F) to approximately 63 ft•lb (85 N•m). **DO NOT TIGHTEN BY TURNING THE SENSOR HOUSING.**

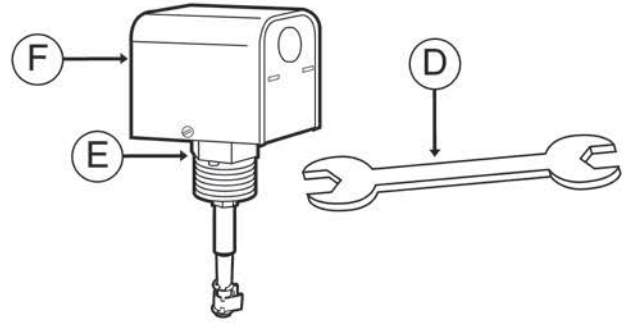

- d. Remove the sensor housing cover (K).

1. **For model RS-1-BR-1**, using a flatblade screwdriver (G), remove the four (4) screws and separate the housing cover (H) from the sensor (I).
2. **For model RS-1-LP**, using a flathead screwdriver or nut driver (J), loosen the two (2) screws and separate the housing cover (K) from the sensor (L).

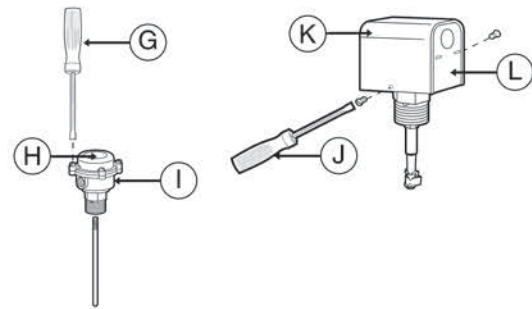

Model RS-1-BR-1

Model RS-1-LP

- Install electrical conduit between **Probe Housing** and **Control Box**.

### NOTE

Refer to and follow local codes and standards when selecting conduit and electrical fittings. Wires from Probe Housing and Control Box must be in their own conduit. If they are run in conduit with other wires, there may be interference that can affect the performance of the control.

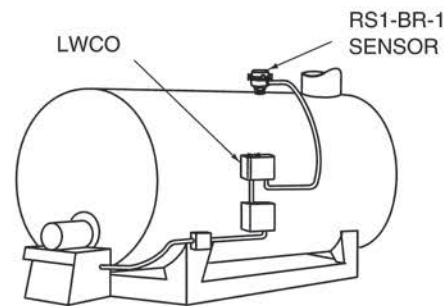

## STEP 3 - Electrical Wiring

### WARNING



#### USE COPPER WIRE ONLY

- To prevent electrical fire or equipment damage, electrical wiring must have a minimum rating of 167°F (75°C) if the fluid's temperature exceeds 180°F (82°C). When sensors are used in fluids above 250°F (121°C), wire must be 18 AWG stranded with glass braided silicone jacket (UL 3071) suitable for high temperature (200°C) service.

Failure to follow this warning could cause property damage, personal injury or death.

- Turn off all electrical power before making or breaking any electrical connections.
- For all wire connections to the terminal block.
  - Strip about 1/3" (8.5 mm) of insulation from the wire.
  - Loosen the terminal screw, **DO NOT REMOVE**.
  - Insert the stripped end of the wire under the terminal screw head, plate or clamp and securely tighten the terminal screw.

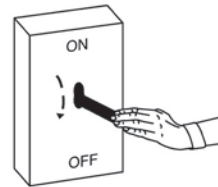

#### Remote Sensor Wiring:

- Connect each wire from probe end to its appropriate terminal in the control.
- Connect wire from remote sensor ground screw to low water cut-off controller chassis ground screw or ground terminal for non-metal connection.

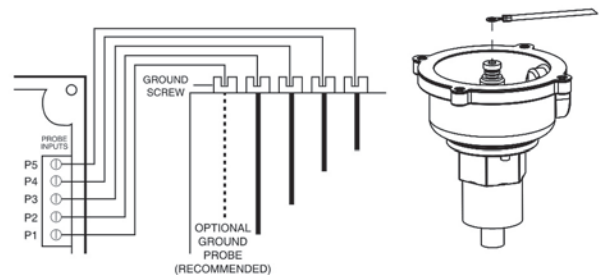

#### Unimount Sensor Wiring:

- Connect ring terminal of wire to probe end under wingnut (A). Do not attempt to loosen or tighten the factory installed hexnuts on the probe assembly. Place ring terminal on top of hexnuts and under the lockwasher and wingnut.
- Connect black wire from probe end to Terminal connection "PROBE" on PCB. Connect green wire from ground screw on the controller's metal chassis to Terminal connection "GND" on PCB.

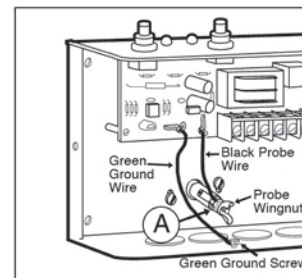

Replace cover (M) and secure screws on assembly to 1-3 ft•lb (1.3-4.0 N•m) to complete installation of the sensor (N). Refer to the corresponding control Installation & maintenance instructions for proper testing of the system.

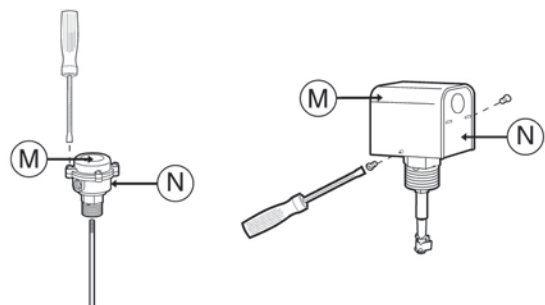

# Troubleshooting

If control fails to operate as required, perform the following diagnostic checks:

1. Check to be sure that the water level in the boiler is at or above the level of the probe.
2. Re-check all wiring to ensure proper connections as specified in boiler manufacturer's wiring diagrams or these instructions.
3. Check to ensure that PTFE tape has not been used on the threaded connection of the electrode to the boiler.
4. Re-check the electrical ground connection for the remote sensor and control unit.
5. Check the quality of the boiler water to ensure adequate conductance.

# MAINTENANCE

## SCHEDULE:

- **Inspect probe annually or more frequently for scale build-up and clean or replace if necessary.** Make certain there is no scale or build-up on the probe or its white PFA insulator. Be careful not to damage the PFA insulator.
- **Replace probe every 10 years.** More frequent replacement of the probe is required if it is used in locales where significant water treatment is required, or in applications with high make-up water requirements.

### NOTE

Clean probe by wiping with non-abrasive cloth and rinsing with clean water. DO NOT use sharp instruments to remove any accumulations of rust or scale.



### CAUTION

Replace Probe if:

- PFA insulator is cracked or worn.
- Probe is loose. Failure to follow this caution could cause property damage, personal injury or death.

- **Replace the low water cut-off every 15 years.**