

Model TC-4 Test-N-Check® Valves For Hot Water Boilers

Does in minutes what used to take hours.

Applications:

For isolation of equalizing lines during low water cut-off testing.

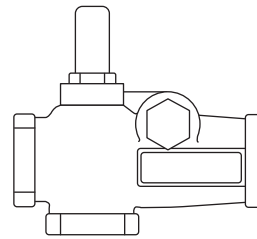

TC-U Upper Valve

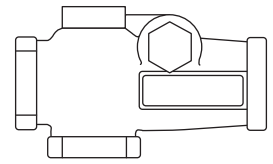

TC-L Lower Valve



OPERATION

Maximum Operating Pressure: 160 psi (11 kg/cm²)

Maximum Operating Temperature: 250°F (121°C)

WARNING



- Before using this product read and understand instructions.
- Save these instructions for future reference.



- All work must be performed by qualified personnel trained in the proper application, installation, and maintenance of plumbing, steam, and electrical equipment and/or systems in accordance with all applicable codes and ordinances.
- To prevent serious burns, the boiler must be cooled to 80°F (27°C) and the pressure must be 0 psi (0 bar) before servicing.
- To prevent serious personal injury from steam blow-down, connect a drain pipe to the control opening to avoid exposure to steam discharge.
- This product can expose you to chemicals including Lead, which is known to the State of California to cause cancer and birth defects or other reproductive harm. For more information go to: www.P65warnings.ca.gov.



- Previous controls should never be installed on a new system. Always install new controls on a new boiler or system.
- Failure to follow this warning could cause property damage, personal injury or death.

CAUTION:

- A more frequent replacement interval may be necessary based on the condition of the unit at time of inspection. McDonnell & Miller's warranty is one (1) year from date of installation or two (2) years from the date of manufacture.

TEST-N-CHECK® VALVES

Simplify Testing of Low Water Cut-offs on Hot Water Boilers

TEST-N-CHECK® VALVES

SIMPLIFY TESTING OF LOW WATER CUT-OFFS ON HOT WATER BOILERS

Good operating practice requires installation of a low water cut-off on a hot water boiler and that it be checked regularly to make certain the control will function properly in the event of a low water condition. Boiler owners and installers need a quick and efficient way to test a low water cut-off on a hot water boiler. Simply opening a blow-off valve below the float chamber may not serve as a valid test and is excessively wasteful of boiler water and fuel. The water level in the float chamber, and the float, must drop far enough to start the control through its cycle of operation. However, water flowing in through the equalizing piping may replenish the level in the float chamber fast enough to delay the necessary float drop, or prevent it altogether.

McDONNELL & MILLER Test-N-Check® Valves have been specially designed for such installations. In normal operation, they allow free circulation of water through the equalizing piping and float chamber. But any sudden onrush of water, such as caused by opening the blowoff, snaps shut a damper in each valve to restrict flow to the float chamber. Water level in the float chamber falls quickly to start the control through its operating cycle, with a minimum loss of boiler water. When blow-off is closed, dampers return to normally open position.

McDONNELL & MILLER Test-N-Check® Valves simply replace the crosses above and below the control in the equalizing lines. Valves have the same dimensions as standard crosses and nipple in the horizontal leg, and allow normal rod clean-out of pipe in both directions. Connections are 1" NPT female tappings. Upper and lower valves are identical, except that the upper valve has vacuum breaker built in to allow for rapid evacuation of the float chamber. They are furnished in sets-one upper and one lower valve, to equip one equalizing line. They can be used with all McDonnell & Miller Low Water Cut-Offs for hot water boilers.

OPERATION OF THE TC-4

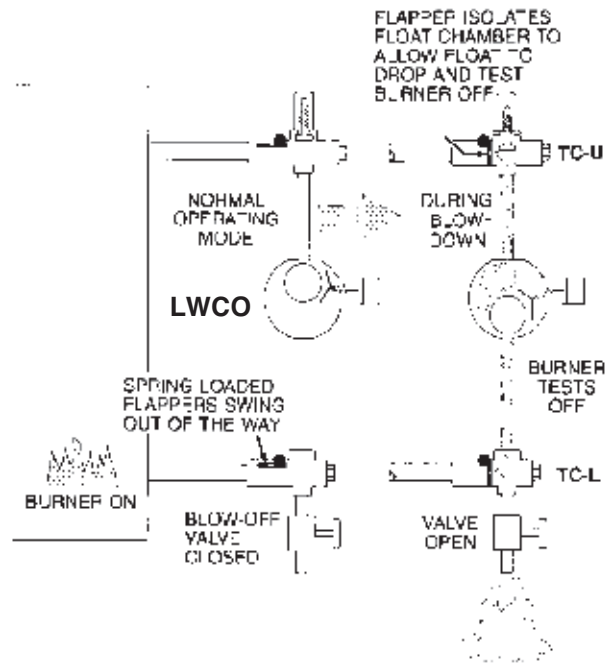

CAUTION



To prevent serious personal injury from steam pipe blow down, connect a drain pipe to the control opening to avoid exposure to steam discharge. If vacuum breaker stem is accidentally depressed, hot water could be discharged causing burns. Failure to follow this caution could cause personal injury.

IMPORTANT:

- When using tape sealant or thread joint compound on pipe or fittings with external threads follow manufacturer's instructions. Do not use tape sealant or thread joint compound on first thread.

TEST-N-CHECK® VALVES

Installation of the TC-4 Test-N-Check® Valve with an Existing Low Water Cut-off

1. Remove the existing low water cut-off by disconnecting the unions in the equalizing lines.
2. Remove the crosses from the upper and lower equalizing lines.
3. Assemble the TC-U (the upper Test-N-Check® valve, with the vacuum breaker) into the upper equalizing line replacing the cross. **NOTE:** The vacuum breaker must be on the top and the long leg must face the boiler.
4. Assemble the TC-L (the lower Test-N-Check® valve, without the vacuum breaker) into the lower equalizing line replacing the cross. **NOTE:** The brass cap must be located above the center of the lower equalizing line, and the long leg must face the boiler.
5. Assemble the blow-down valve into the bottom port of the TC-L.
6. Assemble 1" NPT pipe plugs into the remaining open port in both the TC-U and TC-L. **NOTE:** The addition of the Test-N-Check® valves in place of standard crosses will extend the low water cut-off approximately 2" farther from the boiler.
7. Reassemble the low water cut-off and vertical equalizing pipe to the upper and lower Test-N-Check® valves.
8. After all piping assembly has been completed, refill the system with water, turn on all electrical supply and bring system to operating conditions. After system reaches operating pressure, inspect to make sure no leaks exist at the threaded connections. Test valves by opening blow-down valve while burner is on to make sure valves operate correctly and low water cut-off shuts burner off.

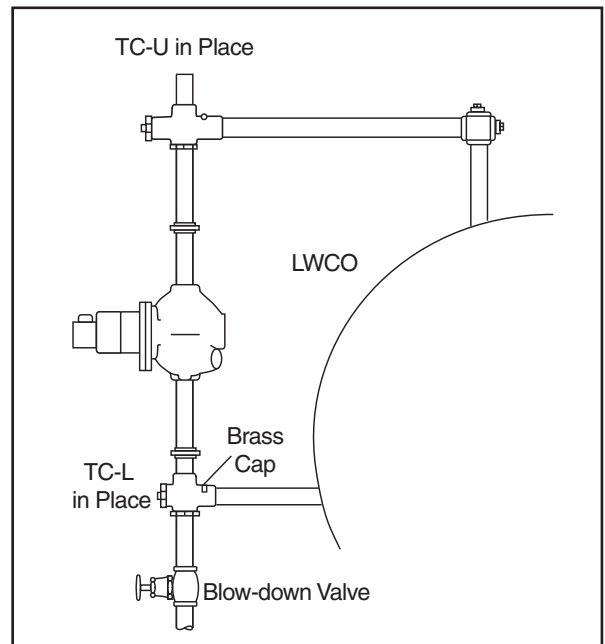
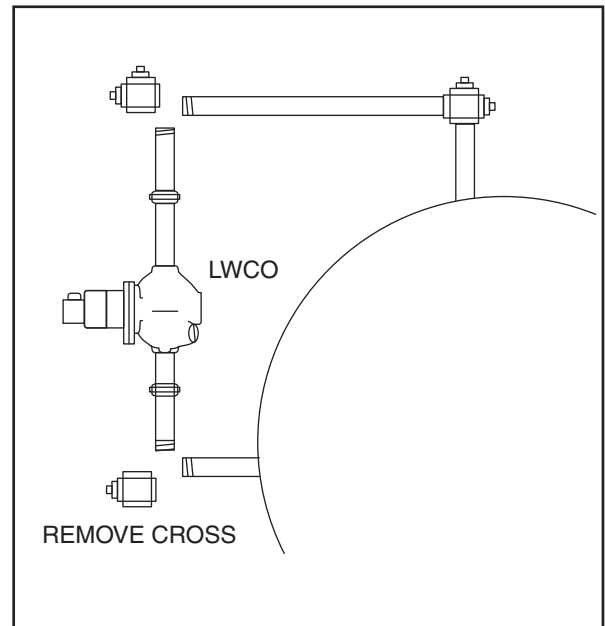

CAUTION



To prevent serious personal injury from steam pipe blow down, connect a drain pipe to the control opening to avoid exposure to steam discharge. If vacuum breaker stem is accidentally depressed, hot water could be discharged causing burns. Failure to follow this caution could cause personal injury.

IMPORTANT:

- When using tape sealant or thread joint compound on pipe or fittings with external threads follow manufacturer's instructions. Do not use tape sealant or thread joint compound on first thread.

TEST-N-CHECK® VALVES

Simplify Testing of Low Water Cut-offs on Hot Water Boilers

Installation of the TC-4 Test-N-Check® Valves with a New Low Water Cut-off

1. Assemble the TC-U (the upper Test-N-Check® valve, with the vacuum breaker) into the upper equalizing line in place of the cross described in the low water cut-off installation instructions.
NOTE: The vacuum breaker must be on the top and the long leg must face the boiler. **NOTE:** Make sure low water cut-off position is located in accordance with the boiler manufacturer's recommended cut-off level.
2. Assemble the TC-L (the lower Test-N-Check® valve, without the vacuum breaker) into the lower equalizing line in place of the cross described in the low water cut-off installation instructions.
NOTE: The brass cap must be located above the center of the lower equalizing line, and the long leg must face the boiler.
3. Assemble the blow-down valve into the bottom port of the TC-L.
4. Assemble 1" NPT pipe plugs into the remaining open port in both the TC-U and TC-L.
5. Complete the installation as described in the low water cut-off installation instructions.
6. After all piping assembly has been completed, refill the system with water, turn on all electrical supply and bring system to operating conditions. After system reaches operating pressure, inspect to make sure no leaks exist at the threaded connections. Test valves by opening blow-down valve while burner is on, to make sure valves operate correctly and low water cut-off shuts burner off.

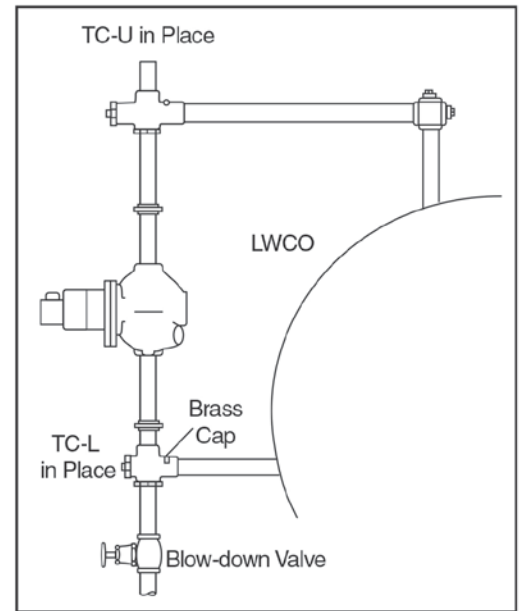

CAUTION



To prevent serious personal injury from steam pipe blow down, connect a drain pipe to the control opening to avoid exposure to steam discharge.

If vacuum breaker stem is accidentally depressed, hot water could be discharged causing burns.

Failure to follow this caution could cause personal injury.

IMPORTANT:

- When using tape sealant or thread joint compound on pipe or fittings with external threads follow manufacturer's instructions. Do not use tape sealant or thread joint compound on first thread.