

Pilot RMG 630a, RMG 640



PRODUCT INFORMATION

**Serving the Gas Industry
Worldwide**



CONTROLS SUPPLY CHAIN
VALVES ACTUATORS INSTRUMENTATIONS

Pilot RMG 630a, RMG 640

Application, characteristics, technical data

Application

- pilot for gas pressure regulators RMG 402, RMG 502, RMG 503, RMG 505
- suitable for natural gas and all non-corrosive gaseous media

Characteristics

- one-stage or two-stage pilot composed of interchangeable cartridge assemblies
- the two-stage version ensures a high regulating accuracy even under high inlet pressure changes
- equipped with inlet pressure (load limiting pressure) gauges, with or without outlet pressure gauge as an optional feature, and fine filter RMG 905
- can be provided with electric remote setpoint adjustment as an optional feature

TECHNICAL DATA				
max. inlet pressure p_{umax}		100 bar		
RMG 630a		<ul style="list-style-type: none"> • two-stage version • for high regulating accuracy • adjustment range (see page no. 3) 		
RMG 640		<ul style="list-style-type: none"> • one-stage version • application at inlet pressure changes: $p_U \leq 15$ bar • adjustment range (see page no. 3) 		
weights		Pilot		
		adjustment range W_n up to		
		1 bar	40 bar	90 bar
		RMG 630a	6.0 kg	5.0 kg
		RMG 640	4.0 kg	3.5 kg
materials		body internal parts diaphragms sealings	aluminium alloy aluminium alloy/steel rubber-like plastic material (NBR) rubber-like plastic material (NBR)	
accuracy class (AC) and lock-up pressure class (SG)		RMG 630a	AC ≥ 2.5	SG ≥ 10
		RMG 640	AC ≥ 5	SG ≥ 10
lock-up pressure zone class (SZ)		SZ 2.5		
temperature range		-20°C ... +60°C (class 2)		
function and strength		according to EN 334		
DIN-DVGW registration		the pilots are components of the regulators		
CE/PED		approved		

ADJUSTMENT RANGES				
Pilot RMG 630a				
adjustment range W_a control stage	setpoint spring			special feature
	No.:	colour	wire-dia. in mm	
0.15 ... 1 bar	1	black	4.5	larger measuring diaphragm
1.00 ... 5 bar	2	yellow	5.6	control stage with diaphragm assembly
2.00 ... 10 bar	3	brown	6.3	control stage with diaphragm assembly
5.00 ... 20 bar	4	red	7.0	control stage with diaphragm assembly
10.0 ... 40 bar	5	green	8.0	control stage with diaphragm assembly
20.0 ... 90 bar	6	white	9.0	control stage with metal harmonica type measuring unit
load limiting stage 5 ... 15 bar		green	5.0	automatically $> p_a$
pilot RMG 640 (one stage version, for inlet pressure $\Delta p \leq 15$ bar)				
adjustment range W_a control stage	setpoint spring			special feature
	No.:	colour	wire-dia. in mm	
0.15 ... 1 bar	1	black	4.5	larger measuring diaphragm
1.00 ... 5 bar	2	yellow	5.6	control stage with diaphragm assembly
2.00 ... 10 bar	3	brown	6.3	control stage with diaphragm assembly
5.00 ... 20 bar	4	red	7.0	control stage with diaphragm assembly
10.0 ... 40 bar	5	green	8.0	control stage with diaphragm assembly
20.0 ... 90 bar	6	white	9.0	control stage with metal harmonica type measuring unit

ACCURACY CLASS AC AND LOCK-UP PRESSURE CLASS SG			
	adjustment range	accuracy class AC	lock-up pressure class SG
RMG 630a	0.15 ... 1 bar	AC 20	SG 30
	> 1 ... 3 bar	AC 10	SG 30
	> 3 ... 5 bar	AC 5	SG 10
	> 5 ... 90 bar	AC 2,5	SG 10
RMG 640	0.15 ... 3 bar	AC 20	SG 30
	> 3 ... 5 bar	AC 10	SG 20
	> 5 ... 90 bar	AC 5	SG 10

Pilot RMG 630a, RMG 640

Design and operation

The gas pressure regulator is designed to keep the outlet pressure constant within given limits, independent of disturbing influences like inlet pressure and flow rate changes.

This regulating operation is controlled by the pilot which feeds loading pressure to the main diaphragm to change its opening position for a regulation of the gas flow within the main valve.

The amplifying valve in the double diaphragm system of the control unit is closed at zero flow. Due to the function of the throttling valve upstream of the pilot ensuring pressure compensation, inlet pressure will prevail in the loading pressure chamber above the main diaphragm. The closing spring gives the force to ensure tight shut-off on zero flow.

4

The valve in the control unit of the pilot reduces the loading pressure to open the regulator (when the two-stage pilot RMG 630a is used, an initial decrease of the load limiting pressure is followed by a reduction of the loading pressure within the loading pressure chamber). The inlet pressure prevailing at the lower side of the main diaphragm moves the diaphragm upwards to set free as much of the slotted valve part as is necessary for outlet pressure control.

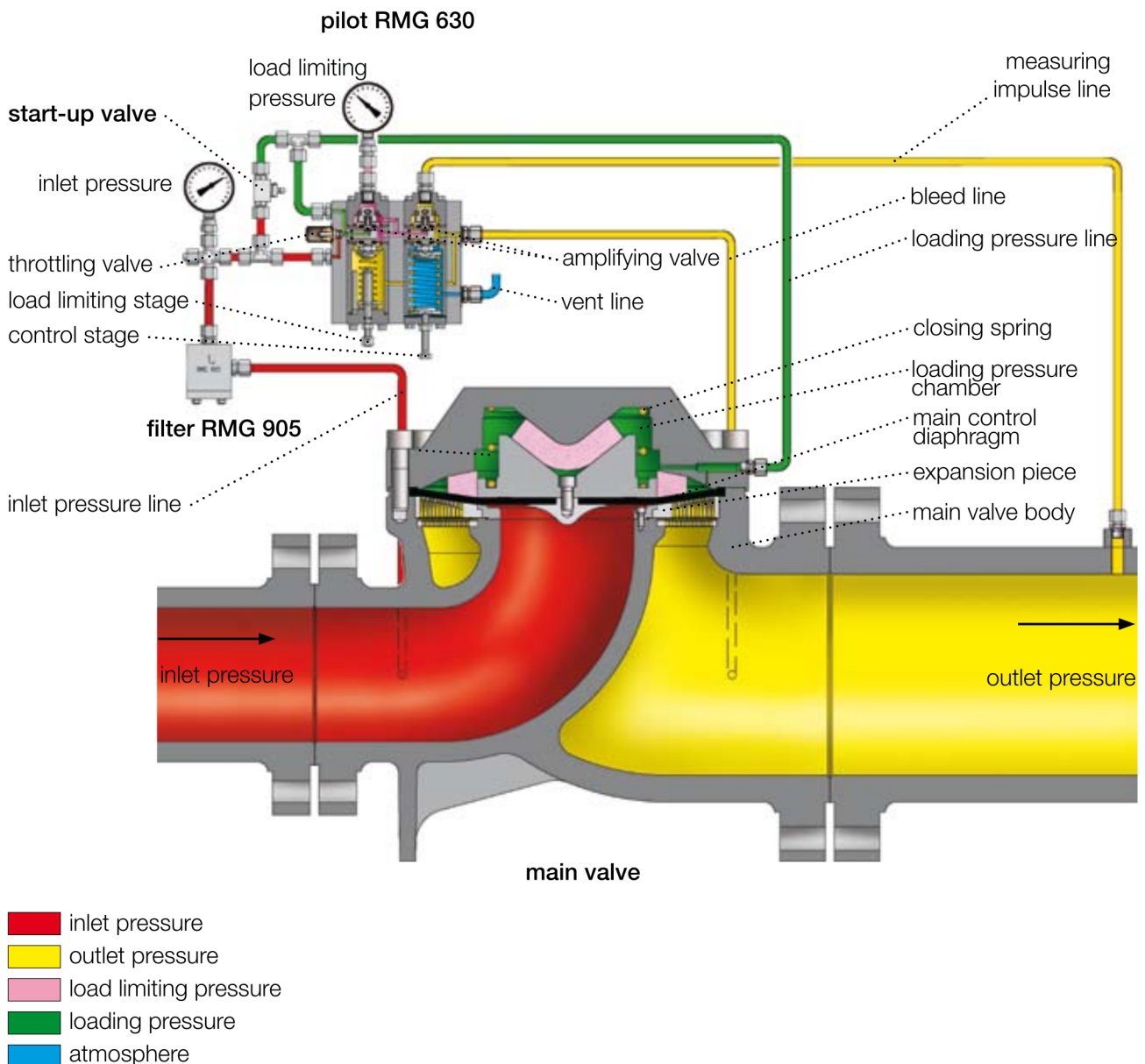

RMG 630a

adjustment range $W_a = (0.15 \dots 1)$ bar

connection for measuring line:

without pressure gauge p_a

with pressure gauge p_a

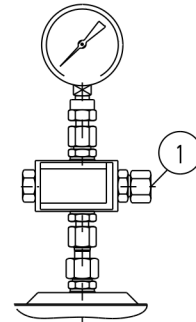
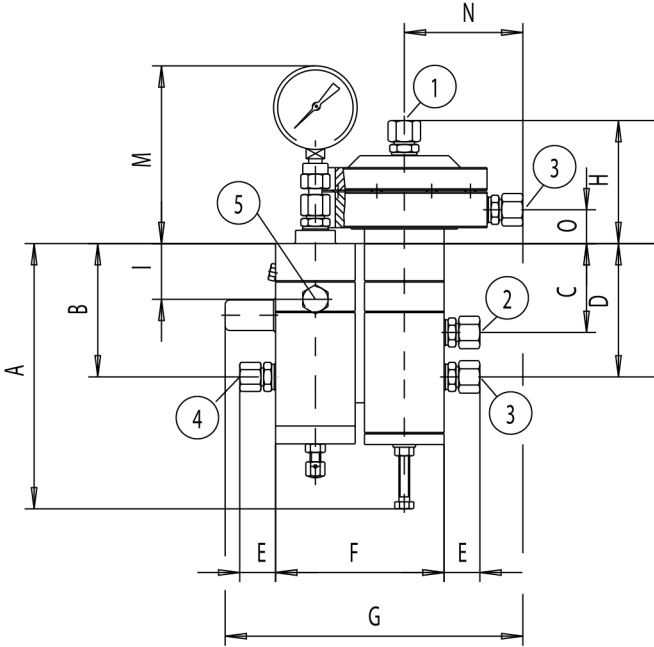

RMG 630a

adjustment range $W_a = (1 \dots 90)$ bar

connection for measuring line:

without pressure gauge p_a

$W_h = (1 \dots 90)$ bar

with pressure gauge p_a

$W_h = (1 \dots 20)$ bar

$W_a = (10 \dots 40)$ bar

$W_a = (20 \dots 90)$ bar

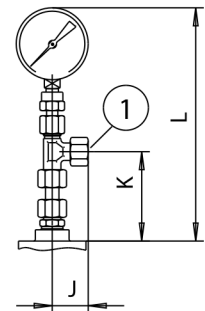
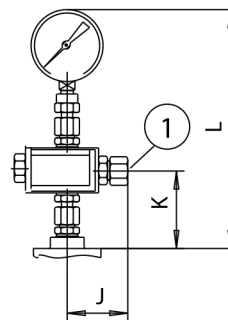
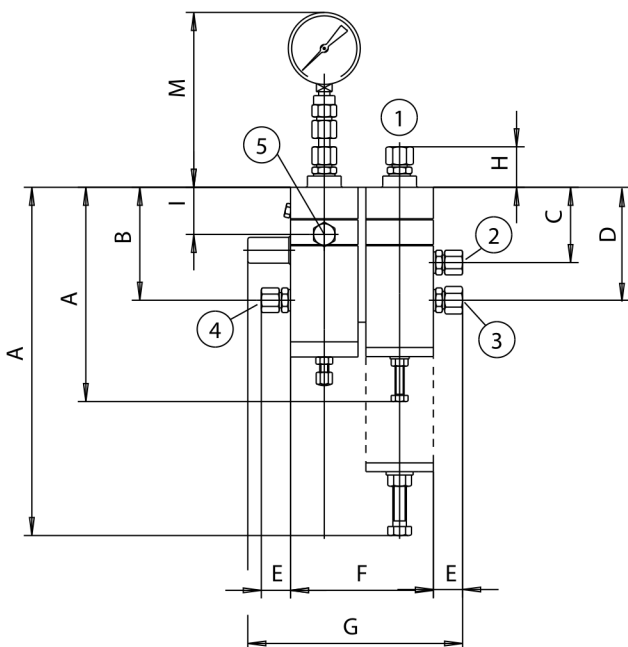

Pilot RMG 630a, RMG 640

Dimensions and connections

RMG 640

adjustment range $W_a = (1 \dots 90)$ bar

connection for measuring line:

without pressure gauge p_a

$W_h = (1 \dots 90)$ bar

with pressure gauge p_a

$W_h = (1 \dots 20)$ bar

$W_a = (10 \dots 40)$ bar

$W_a = (20 \dots 90)$ bar

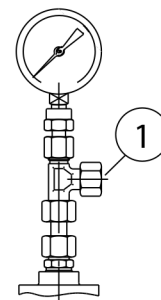
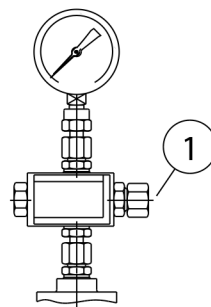
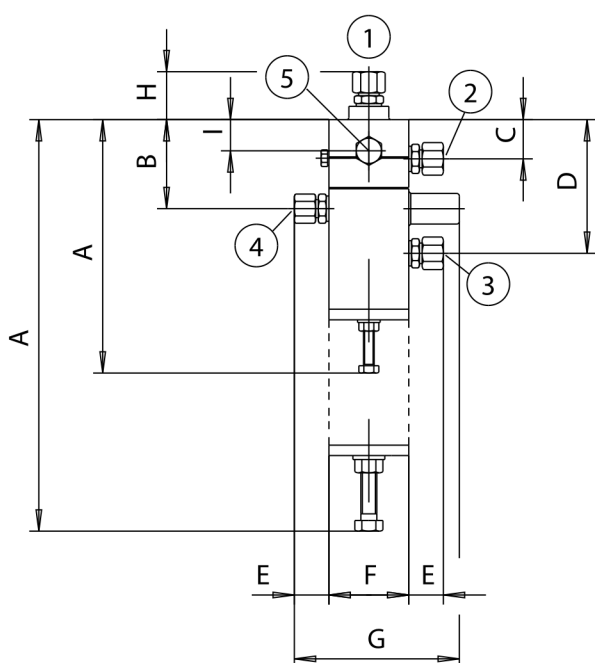

DIMENSIONS IN MM

Pilot	adjusting range	A	B	C	D	E	F	G	H	I	J	K	L	M	N	O
RMG 630a	$W_a = (0.15 \dots 1)$ bar	195	101	67	101	26	127	225	93	42	56	88	230	132	90	24
RMG 630a	$W_h = (1 \dots 40)$ bar	195	101	67	101	26	127	191	36	42	56	68	209	156	-	-
RMG 630a	$W_a = (20 \dots 90)$ bar	315									32	75	202			
RMG 640	$W_h = (1 \dots 40)$ bar	195	67	30	101	26	60	60	36	24	56	68	209	-	-	-
RMG 640	$W_a = (20 \dots 90)$ bar	315									32	75	202			

CONNECTIONS

① measuring line	at outlet pressure line	E 12, thread M 14 x 1.5
② bleed line	at main valve or outlet pressure line	E 12, thread M 14 x 1.5
③ vent line	to the open air	E 12, thread M 14 x 1.5
④ inlet pressure line	at inlet pressure line	E 10, thread M 14 x 1.5
⑤ loading pressure line	at main valve	E 10, thread M 14 x 1.5

RMG 630a - 2 - So

example:

PILOT		
pilot		RMG 630a RMG 640
SETPOINT SPRING OF PILOT CONTROL STAGE		
setpoint spring No.	setting range W_h in bar	
1	0.15 ... 1	1
2	1 ... 5	2
3	2 ... 10	3
4	5 ... 20	4
5	10 ... 40	5
6	20 ... 90	6
SPECIAL VERSION		
special version (is to be specified in detail)		So

