

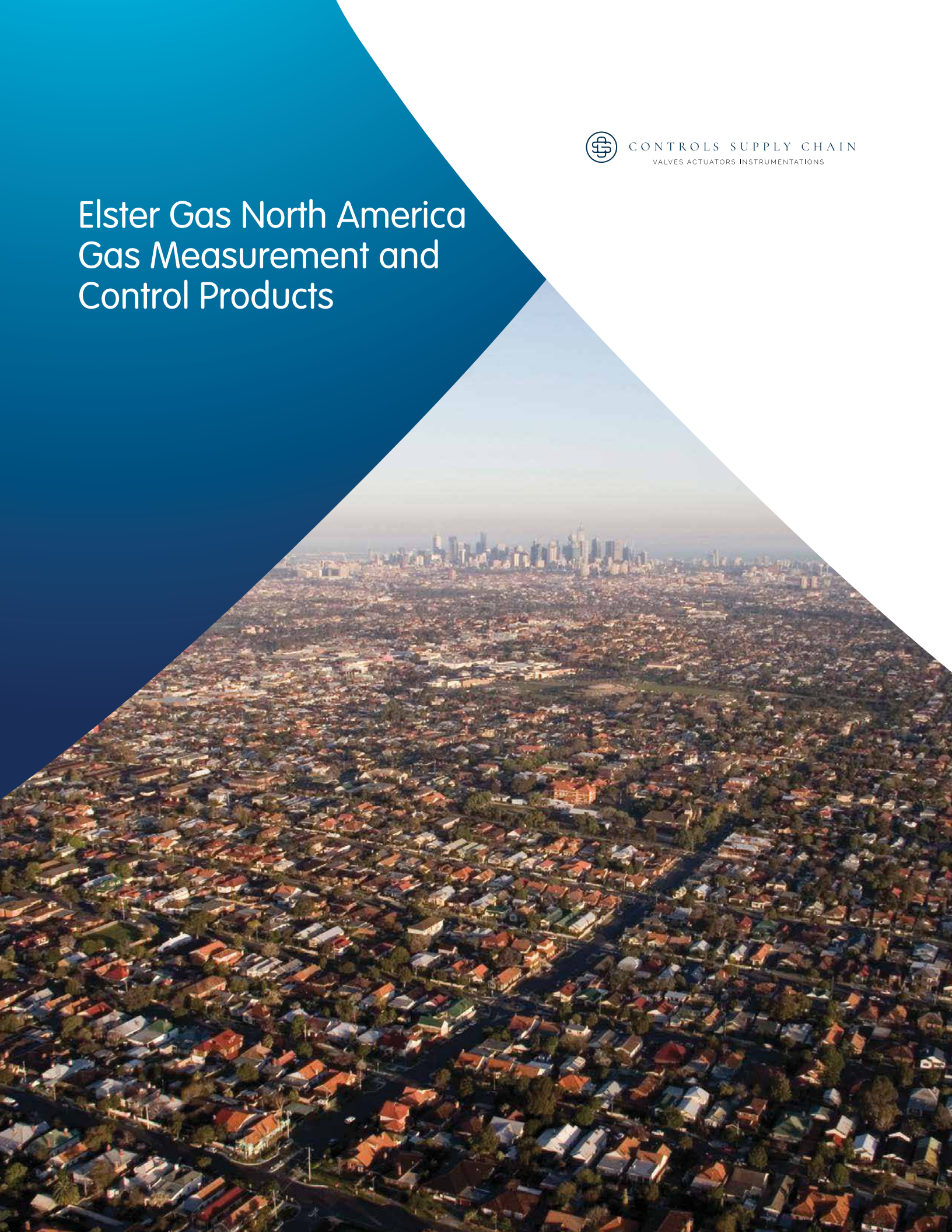

CONTROLS SUPPLY CHAIN
VALVES ACTUATORS INSTRUMENTATIONS

Elster Gas North America Gas Measurement and Control Products



Bring Upstream and Downstream Application Knowledge and Expertise Together

Table of Contents

- 03 Elster Gas North America
- 04 Selecting the Correct Meter
- 05 Solutions that Measure, Regulate and Manage
- 06/07 Diaphragm and Laboratory Meters
- 08/09 RPM Series Rotary Meters
- 10/11 Turbine Meters
- 12/13 Ultrasonic Meters
- 14 Pressure Regulators
- 15 Selecting the Correct Pressure Regulator
- 16/17 Low and Medium Pressure Regulators
- 18 High Pressure Regulators
- 19 Meter/Regulator Accessories
- 20 Safety Shutoff Devices and Filters
- 21 Prefabricated Meter Sets and Components
- 22 Repair & Refurbish Services
- 23 AMI/AMR Solutions



Elster Gas North America combines the products and resources of well-recognized and respected brands such as Elster American Meter, Elster Perfection, Elster Canadian Meter, Elster Instromet, and Elster Meter Services. Elster's aim is to help its customers increase their productivity and efficiency through our portfolio of measurement and distribution products for the gas industry. Hallmarks of our brands include long-term product reliability and performance, lowest total cost of ownership and installation, and outstanding technical training, field support and customer service.

Elster Gas North America supplies a comprehensive offering of Natural Gas and Propane products used for gas distribution in commercial, industrial and residential markets worldwide. The company's innovative products are used to improve the safety, integrity and speed of gas distribution.

Respected throughout the world as a technology leader, Elster Gas North America has always been at the forefront of innovation in the gas industry. The company's Research and Development centers in Cleveland, OH and Nebraska City, NE are exclusively dedicated to the art and science of gas distribution and measurement technology.

Elster Gas North America is a division of Elster, a world leader in advanced metering infrastructure, integrated metering, and utilization solutions to the gas industries. Elster's systems and solutions reflect over 170 years of knowledge and experience in measuring precious resources and energy. Elster's AMI solutions enable utilities to cost-effectively generate, deliver, manage, and conserve the life-essential resources of gas.

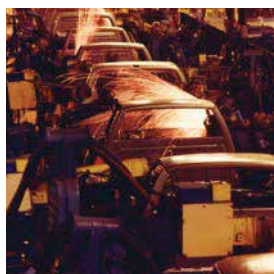



Elster American Meter

Elster American Meter is the world's leading manufacturer and supplier of measurement and control products for the natural gas industry. Elster American Meter's complete product and service portfolio includes long-term product reliability and performance, lowest total cost of ownership and outstanding technical training, field support and customer service.



Elster Perfection

Elster Perfection is the world's leading manufacturer of non-metallic mechanical joining products for natural gas and propane gas distribution systems. Elster Perfection's complete mechanical polyethylene gas distribution system allows installers to connect with integrity, safety, and speed without using special tools or expensive equipment.



Elster Instromet

Elster Instromet is a leading supplier of ultrasonic gas flow meters worldwide, and is also a developer and manufacturer of low and medium pressure turbine meters for both custody transfer and non-custody transfer applications. The firm operates in industrial, commercial, and residential markets throughout the world.



Elster Meter Services

Elster Meter Services offers services for all aspects of measurement; meter remanufacturing, various meter refurbishing programs, metrology services and measurement consulting services.

Elster AMCO de Mexico

Elster AMCO de Mexico is the leading supplier of gas measurement and control products as well as non-metallic mechanical joining products in Latin America. Elster AMCO de Mexico's complete product and service portfolio includes the brand names Elster American Meter, Elster Instromet and Elster Perfection.



Elster Canadian Meter

Elster Canadian Meter is dedicated to the sales and marketing of gas distribution, measurement and control products for the Canadian natural gas industry. Elster Canadian Meter's complete product and service portfolio includes: turbine meters, rotary meters, diaphragm meters, regulators, AMI/AMR solutions and Elster Perfection's line of products for gas distribution piping systems.

Elster Integrated Solutions

Elster Integrated Solutions delivers AMR and AMI systems that help utilities improve revenue cycle services, customer service, and delivery reliability as well as implement demand response and conservation programs. EIS delivers and integrates metering automation solutions for utility customers so that they can better manage their business in the area of electric, water, and gas usage as well as facilitate new end-customer programs. Experienced in field-proven AMR/AMI system deployment, EIS enables business and customer management from metering information. Core to EIS solutions is the use of intelligent standards-based communications.

Selecting the Correct Meter

Elster Gas North America supplies four types of meters - diaphragm, rotary, turbine and ultrasonic.

Diaphragm meters are positive displacement devices that have four-volume measurement compartments formed by a two separate convoluted diaphragms. A small pressure drop across the meter causes it to cycle so these compartments alternately fill with gas from the inlet, and then empty at the outlet. By counting the number of cycles, the meter provides a measure of gas volume.

Rotary meters are also positive-displacement measurement devices. In this case, a pair of hourglass-shaped impellers form the fixed-volume compartments. When downstream demand initiates the flow of gas, the impellers rotate to receive a fixed volume of gas at the inlet and then discharge it at the outlet.

In place of fixed-volume compartments, a turbine meter has a rotor in the gas stream. As gas flows through the meter, the rotor turns at a speed that is proportional to the rate of gas. This type of meter is termed an inferential meter.

The Ultrasonic flow meter is another type of inferential meter that determines the average velocity of the gas flow through the use of sonic pulses and is used in custody transfer applications. The patented single and dual reflection path technology used in the series continues to be a popular option in the marketplace. Available in sizes ranging from 4"-64", this flow meter line features a turndown

ratio as high as 150:1 and can be used in bi-directional applications.

Deciding which type of meter is the best choice for a particular application depends upon the following:

- The pressure of the gas being measured
- The maximum flow rate to be measured
- The minimum flow rate to be measured

Gas Pressure

The first consideration in selecting a gas meter is the pressure of the gas being measured. Depending on the specific model, diaphragm meters have pressure ratings up to 100 PSIG. Rotary meters can operate at pressures up to 285 PSIG. For applications above 285 PSIG, select a turbine meter or ultrasonic meter.

Maximum Capacity Ratings

Capacity ratings for the various types of meters overlap as shown in the chart below. With badge (line) pressures of 0.25 PSIG, the following meter choices are typical:

- Diaphragm Meter - capacities of 5,000 CFH or less
- Rotary Meter - capacities of 16,000 CFH or less
- Turbine Meter - capacities of 150,000 CFH or less
- Ultrasonic Meter - capacities of 3,531,600 CFH or less

The overlap in capacity ratings allows

for versatility when selecting the correct meter for differing applications. For example, an application's maximum flow rate may fit into the "typical" selection shown below for a diaphragm meter, but the pressure of the gas being measured may be above 100 PSIG. In this case, a small rotary meter would be considered.

Rangeability

Another consideration to keep in mind when selecting a gas meter is the rangeability of the meter. Rangeability is the ratio of maximum flow rate to minimum flow rate that can be measured with the specified accuracy of the meter.

Elster American Meter diaphragm meters provide an accuracy of +/- 1% of reading with a rangeability of greater than 100:1. Therefore, an AC-250 meter with a maximum rating of 250 SCFH will provide +/- 1% accuracy for flow rates from 2.5 to 250 SCFH.

For rotary meters, rangeability at +/- 1% accuracy ranges from 30:1 up to 120:1, depending on the specific meter size. For applications where +/- 2% accuracy is sufficient, rotary meters will provide rangeabilities up to 225:1.

A distinct feature of turbine meters is that the rangeability increases as the measuring pressure increases, providing a wider operating range at higher pressures. For example, a 3" GTS turbine meter operating at a line pressure of 0.25 PSIG has a rangeability of 12:1. The maximum rated capacity at this pressure is 10,000 SCFH, providing an operating range of 833 to 10,000 SCFH within the accuracy limitation of +/- 1%. The same meter in an application with a line pressure of 100 PSIG has a rangeability of 33:1 and a maximum rated capacity of 79,000 SCFH. Given this, the meter has a measuring range of 2,360 to 79,000 SCFH within the accuracy limitation of +/- 1%. Ultrasonic meters typically have a rangeability as high as 100:1.

Meter Selection by Capacity and Pressure

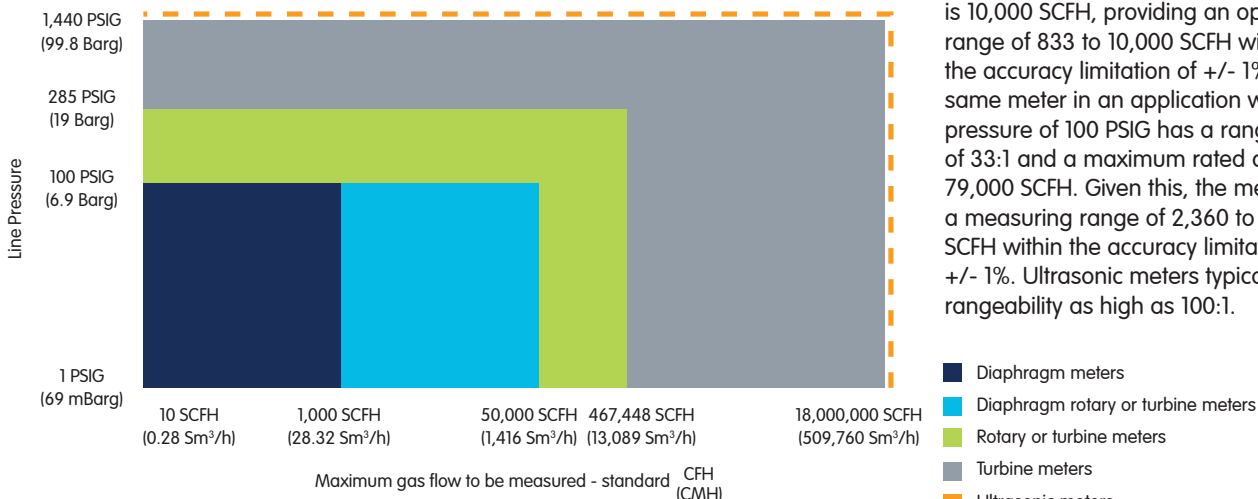

Solutions that Measure, Regulate, and Manage

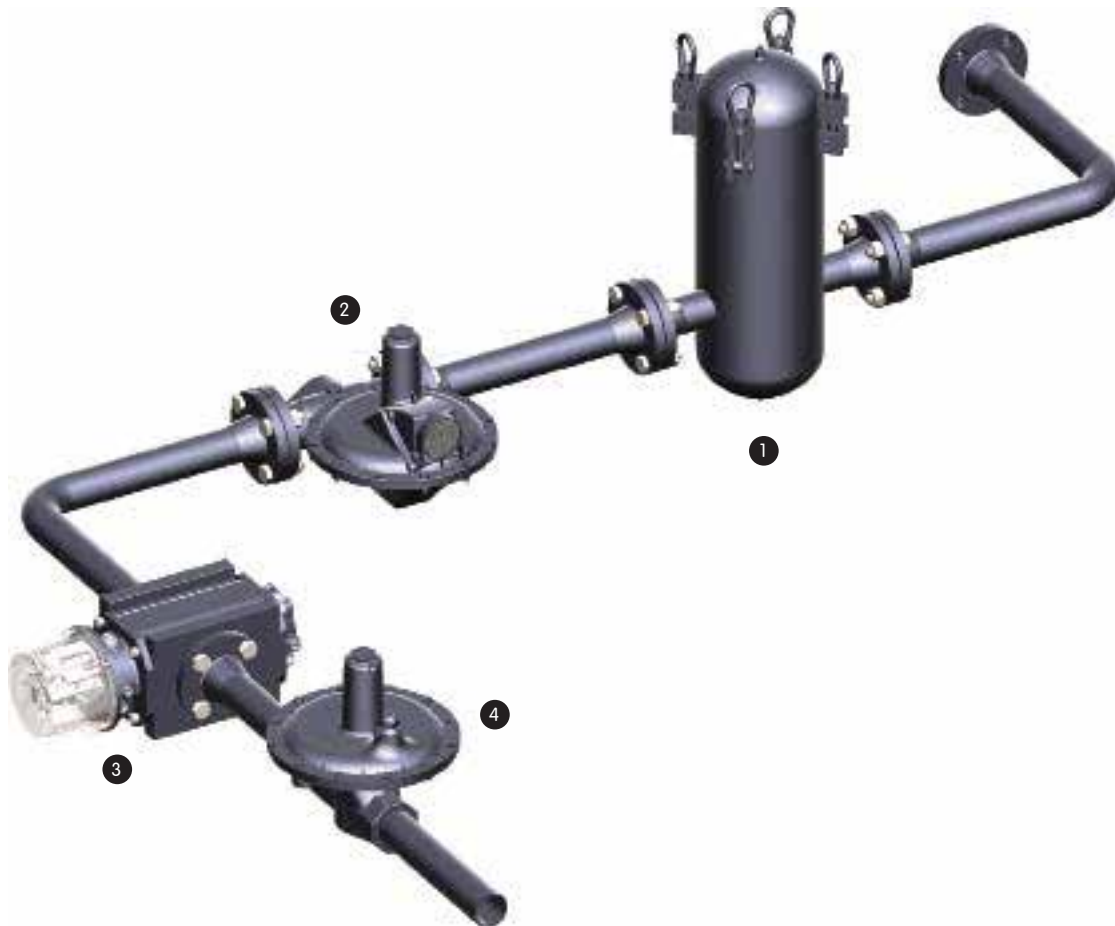

Elster American Meter supplies the industry's broadest line of equipment and services for the measurement, regulation, and management of energy flow (natural gas, propane or other industrial gases) from the well head to the burner tip, over a wide variety of applications, and always with a goal of maximizing the efficient, cost-effective use of resources.

- 1 Kleanline Filters or gasket strainers remove dust, dirt, and debris from the gas stream thereby extending downstream equipment life, improving safety, and reducing maintenance.
- 2 A full line of regulators; axial flow valves, the 1800 Series Industrial, the 2000 Series Industrial, the 1800 PFM, the 1800 CPB2 along with a complete line of Service Regulators are available that can reduce the pressure and maintain a stable

downstream pressure. Options including Full Relief, Partial Relief, Overpressure Shutoff, Underpressure Shutoff, along with various combinations insure a safety operating environment for the downstream piping system and equipment

- 3 Four types of meters are available depending on the pressure and flow rates required to meet the demand. Diaphragm meters can handle flows from a pilot light up to 5000 actual cubic feet per hour at pressures up to 100 PSIG. Rotary meters handle pressures up to 285 PSIG and flows up to 16,000 actual cubic feet per hour. Turbine meters operate at pressures up to 1480 PSIG and flow rates up to 150,000 actual cubic feet per hour. Finally, ultrasonic meters that provide a very high degree of accuracy ranging in

sizes from 4" up to 64" can handle very large load requirements for large industrial customers and gas transmission applications.

- 4 Downstream regulators such as the 3000 Series, the J48, and the J78RS can further reduce the pressure to serve the individual appliances or building equipment.

Elster American Meter also provides accessory equipment and services such as Needle Valves, Safety Shutoff Devices, Splashguards, Straightening Vanes, Restrictor Plates, Remote Volume Pulsers, SNAP provers, metrology services, along with a complete line of AMI/AMR systems through Elster Integrated Solutions. Elster Gas North America's *Solutions that Measure, Regulate, and Manage*.

Diaphragm Meters

Elster American Meter diaphragm meters have an outstanding record for durability and reliability.

Features

- Light, compact profiles
- Durable valve material to minimize wear
- One piece body design to eliminate the need for machined joints and gaskets, and the possibility of internal leakage
- Molded, convoluted diaphragms for smooth operation and long life
- Low-friction seals
- Adjustable tangents
- Rugged flag rods for positive alignment and sustained accuracy
- Large, self-lubricating bearings
- Single-coat polyester primer and high solids polyurethane top coat



Diaphragm Meters

Elster American Meter is the industry's leading supplier of diaphragm meters with models for applications ranging from domestic service to large industrial users. The housing consists of a one-piece cast aluminum alloy body and aluminum alloy top and covers. Elster American Meter diaphragm meters have an outstanding record for durability and reliability.

Options

Temperature Compensation

All diaphragm meters can be supplied with temperature compensation. This feature converts the volume of gas measured at actual (line) temperatures from -30° to +140° F (-34° to 60° C) to the equivalent volume at standard 60° F (15.5° C).

Types of Indexes

Meters can also be supplied with your choice of a circle-type, odometer, or pressure-compensating index.

Connections

Various types of connections including swivels, caps, washers, flanges, curb meter style, or pipe nipples can be supplied.

An ultra-tough polyurethane coating can be applied to the outside of the meter for the ultimate in corrosion protection.





AC-250/AM-250

- Nominal capacity = 250 CFH (7.1 m³/h)
- Maximum pressure rating = 5 PSIG or 10 PSIG (345 or 690 mBarg)
- AC-250 - Top connections
- AM-250 - Side connections



AT-210/AT-250

- Nominal capacity 210 CFH (5.9 Sm³/h) 250 CFH (7.1 m³/h)
- Maximum pressure rating = 5 PSIG or 10 PSIG (345 or 690 mBarg)
- Connections suited for tin case meter replacement



AL-425

- Nominal capacity = 425 CFH (12.0 m³/h)
- Maximum pressure rating = 10 PSIG or 25 PSIG (690 mBarg or 1.7 Barg)
- Top connections



AC-630

- Nominal capacity = 630 CFH (17.8 m³/h)
- Maximum pressure rating = 25 PSIG (1.7 Barg)
- Top connections



AL-800/AL-1000

- Nominal capacity
AL-800: 800 CFH (22.6 or m³/h)
AL-1000: 1,000 CFH (28.3 or m³/h)
- Maximum pressure rating
AL-800: 20 PSIG or 100 PSIG (1.4 or 6.9 Barg)
AL-1000: 25 PSIG or 100 PSIG (1.7 or 6.9 Barg)
- Top connections



AL-1400/AL-2300/AL-5000

- Nominal capacity
1,400 CFH (39.6 m³/h)
2,300 CFH (65.1 m³/h)
5,000 CFH (141.6 m³/h)
- Maximum pressure rating = 100 PSIG (6.9 Barg)
- Side connections
- Available as remanufactured meters only



BK-G4 Diaphragm Meters

- Nominal capacity = 200 CFH (5.7 m³/h)
- Maximum pressure rating = 5 PSIG
- Top connections



Dry-Test Meter

These meters are used for extremely accurate measurement of low volumes of any gas that is unsaturated with water vapor. Volume is read on a large, 6" circular dial with sweep hand and four totalizing hands. Units are available with dial subdivisions as small as 0.001 CF for very low-volume measurement.



Wet-Test Meter

These laboratory instruments are extremely precise positive displacement meters which are individually calibrated under controlled conditions. Using a liquid-sealed rotating drum as the measuring element, these meters provide large, easy-to-read dials with subdivisions as low as 0.0005 CF. Models are available calibrated in CF or liters.

RPM Rotary Gas Meters

Elster American Meter's RPM rotary meters are a positive displacement meter used to measure natural gas and other various non-corrosive industrial gases (air, nitrogen, carbon dioxide) over a wide range of flow rates and operating pressures.

Features and Advantages

- ANSI B 109.3 compliant
- 7 meter sizes ranging from 1500 - 16,000 CFH, connections from 2"-4"
- Heavy duty design of the body resists bending to prevent "lock ups"
- High rangeability from low flow to high flows insures accuracy
- Low pressure drop across meter even at high flows
- Reverse flow capability standard on all models
- Flanged to meet ANSI 125/150 specifications
- Differential pressures taps on inlet and outlet flanges
- Non-lubricating indexes reduce maintenance
- Vented index cover reduces condensation
- High impact resistant, UV stabilized index covers
- Anodized extruded aluminum body and impellers
- Splash lubrication for main bearings
- AMR/AMI Compatible



RPM Rotary Gas Meters

Elster American Meter's RPM series rotary meters provide accurate measurement and outstanding long-term performance for critical custody transfer applications. The positive displacement rotary design has a proven track record of long-term accuracy and reliability, thus, earning its position as a leading metering technology in the natural gas utility industry worldwide.

The unparalleled performance of the RPM meter is further enhanced by its versatility. All models are available with a variety of instrumentation accessories commonly used in utility and industrial applications for interfacing with data acquisition and meter reading systems. All models have the highest pressure rating of any standard line of rotary meters on the market allowing the RPM application flexibility. All meters can easily be configured for reverse flow installations which can reduce installation costs and mitigate unsightly and undesirable piping configurations.

With over 170 years of metering history and innovation, Elster American Meter RPM meters provide measurement experts the security of knowing their measurement is uncompromised. When it comes to accuracy, reliability, and versatility, choose the most trusted name in measurement – Elster American Meter.

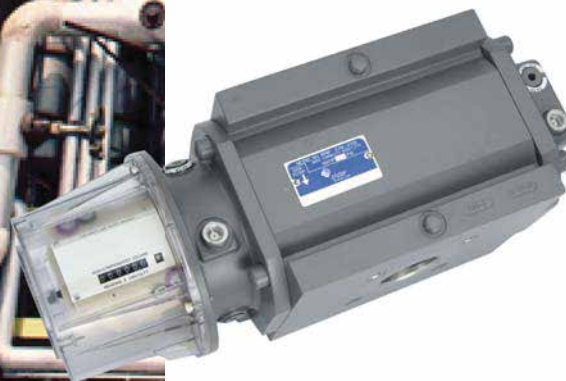

Standard models and optional accessories provide versatility and flexibility to fit the most demanding applications.



RPM Series Rotary Meters meet the following:

- ASME Boiler & Pressure Vessel Code; Section VIII
- ANSI B16.5 Flanged Pipe & Fittings
- ANSI B31.8 Gas Piping
- ANSI B109.3 Rotary Gas Meters (2000)
- 49 CFR 192 Min. Federal Safety Standards
- National Safe Transit Association (NSTA-1A-Packaging)
- Measurement Canada approval AG-0420 REV 4

Standard Models

CTR - Uncorrected Mechanical Totalizer

CID - CTR with Instrument Drive

CRVP - CTR with Remote Volume Pulsar (RVP)

CMTC - Continuous Mechanical Temperature Compensator

TCID - CMTC with Instrument Drive

TRVP - CMTC with Remote Volume Pulsar (RVP)



Optional Accessories

Other options include

- Reverse Flow
- Thermowell
- RVP Mounting Kit
- Instrument Drive Kit
- Pete's Plugs II®
- Mounting bolts and flange gaskets
- Gasket Strainers
- Pressure Compensating Indexes
- Restricting Orifice Plate
- Differential Pressure Gauge Kit
- 1-1/2" NPT Mounting Kit for 2" flanged meters
- Proving Clamp
- Factory AMR/AMI Installation

Available Register Masking & Multipliers

RPM register masking & multipliers are available in both English and Metric units.

English Units (FT³)

- 4 x 1000 ^{1,3}
- 5 x 100 ^{1,2,3}
- 5 x 1000 ^{2,3}
- 6 x 10 ¹
- 6 x 100 ^{1,2,3}
- 6 x 1000 ⁴

Metric Units (m³)

- 5 x 0.1 ¹
- 6 x 0.1 ¹
- 6 x 1 ^{1,2,3}
- 6 x 10 ^{2,4}



¹ 1.5M-11M CTR, ² 16M CTR, ³ 1.5M-11M CMTC, ⁴ 16M CMTC

Turbine Meters

These compact, high-performance turbine meters are designed for reliable long-term service.

Features

- Flush-type bearing lubrication system (GTS and AccuTest)
- Aluminum rotors for high pressure models or meters with high-frequency pulse output (GTS and AccuTest)
- High-frequency RF pulser that monitors rotor condition (GTS and AccuTest)
- One output gear train for 3" to 8" meters reduces spare parts inventory
- High efficiency inlet flow conditioners
- Interchangeable pre-calibrated cartridges for easy maintenance/change out



Turbine Meters

Elster supplies several variations of compact, high-performance turbine meters. Each variation is designed to provide accurate totalization of high volume gas flows.

Turbine meters are designed to accurately measure natural gas, air, nitrogen, carbon dioxide, propane vapor, and other non-corrosive gases for large volume commercial and industrial uses. Meters are available in sizes ranging from 3" up to 12", pressure ratings up to 1480 PSIG, operating temperature range of -40°F to 140°F (-40°C to 60°C), and maximum flow rates at 7" W.C. pressure (.60 Specific Gravity Gas) of:

3"	–	10,000 CFH
4"	–	18,000 CFH
6"	–	35,000 CFH
8"	–	60,000 CFH
12"	–	150,000 CFH

Meters meet manufacturing standards as specified in ANSI/ASME/AGA Report Number 7.

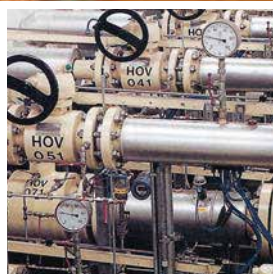



AccuTest Transfer Proving Turbine Meters

These innovative units combine all the features and benefits of Elster American Meter's GTS turbine meters with an additional integral reference meter that provides on-site, in-line testing under actual operating conditions.

An AccuTest meter, with your laptop computer and supplied software, becomes an in-field transfer proving system without removing the cartridge from the meter. AccuTest meters are available in 4", 6" and 8" sizes with standard (45°) or extended (30°) capacity aluminum rotors.

AccuTest meters combined with Mercury Instruments PTA correctors will result in a high-performance turbine meter along with pressure, temperature and accuracy correction.



3" GT Meter

GT meters are available in either 3" or 12" pipe sizes and pressure ratings up to 1,480 PSIG.



GTS Meter

GTS Meters are basic turbine meters available in 4", 6" and 8" sizes, and come standard with: pre-machined housings to allow upgrade to AccuTest self-test model; flush-type lubrication system to clean main bearings while meter is in operation; both inlet and outlet Flo-Guides®.



GTX Meter

GTX meters are available in line sizes from 4" to 8" and a pressure rating of 175 PSIG. These meters are a cost-reduced version of the GTS meter, specifically designed for in-plant measurement or where reduced maintenance is a requirement.

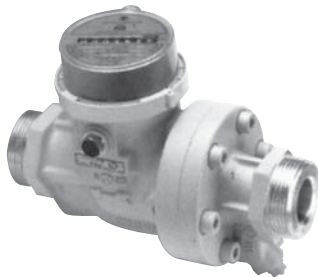

QA Turbine Meters

- Nominal capacities up to 14,000 SCFH (396 Sm³/h)
- Maximum pressure rating = 175 PSIG (12.1 Barg)
- Connections: 1" and 1-1/2" NPT, 2", 3", 4" flanged (wafer-style)

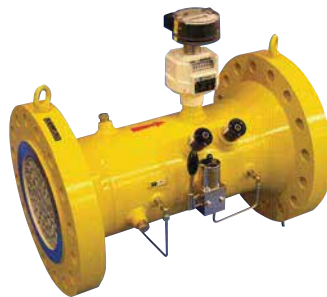

Turbine Gas Meters X & XIC

- Suitable for all non-corrosive gases
- Standard with LF & HF outputs
- X turbine meter incorporates the patented X4X® flow conditioner

Ultrasonic Meters

The Q.Sonic series meters are the most accurate and flexible ultrasonic meters for natural gas custody transfer applications in the world.

Advantages

- Large turn down ratio
- Bi-directional
- Flow profile detection
- CMB signal processing
- Swirl and asymmetry detection
- Reflective technology
- TwinSonic, a Q.Sonic with redundant electronics
- Uniguard™ diagnostic software
- Flow conditioner and adjacent spool pieces assure measurement and operational integrity
- Advanced path configuration
- Dynamic flow profile correction
- Extended diagnostic functions
- Ultrasonic noise suppression
- Application Related Path Substitution (ARPS)
- High-pressure calibration
- Material certificates: EN 10204 - 3.2, NACE MR-01-75
- No moving parts
- No pressure drop
- ISO CD17089 compliant
- AGA-9 compliant
- Highest noise immunity
- Highest repeatability



Theory of Operation

An ultrasonic flow meter takes advantage of the principle that an ultrasonic pulse travels faster with the gas flow than against the flow. The larger the difference between the upstream travel time versus the downstream, the more gas has passed through the meter. The advent of high speed computer processors has made it possible to detect very small time differences between the upstream and the downstream travel times. Because ultrasonic meters do not depend on the kinetic energy from the field, very low flows can be detected.

Ultrasonic Flow Meters

Based on performance, reliability and availability the patented single and double reflection paths have proven to be the standard in custody transfer gas measurement systems. The Q.Sonic series meters are the most accurate and flexible ultrasonic meters for natural gas custody transfer applications, and our single and double reflective path technology delivers unparalleled flow velocity recognition and range. Q.Sonic meters are available in sizes ranging from 4" to 64" with a turndown ratio as high as 100:1 and can be used in bi-directional applications.



Elster Instromet Bounce Technology

Elster Instromet uses a combination of two distinct path configurations to make it possible to not only measure the gas flow, but also the swirl angle. The unique network of single bounce and double bounce paths provides analysis of the flow profile and swirl components of the gas. The measurement of the flow is insensitive to the orientation of the meter with respect to the pipe. Due to the nearly six times longer path length, the Elster Instromet multi-path meter provides a much more accurate flow velocity measurement.

Along with improved flow profile and swirl information, the reflective path matrix provides diagnostic information about the inside pipe diameter condition. Changes in the path length caused by contamination build-up inside the pipe can be reported and alarmed by the diagnostics in the Elster Instromet meter.

Maintenance Savings:

Ultrasonic Meters have no moving parts, reducing their need for maintenance. Utilizing our state of the art diagnostic software, UNIFORM, the meter performance can be checked with limited user interface. UNIFORM automatically produces detailed test reports that ascertain the health of the meter.



Swirl Paths



Diagonal Paths

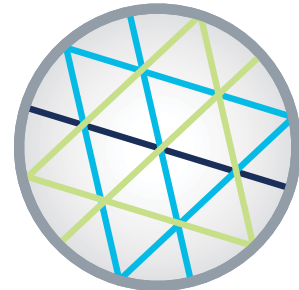

Cross-sectional Paths



Q.Sonic 3 Path



Q.Sonic 4 Path



Q.Sonic 5 Path

Pressure Regulators

Designed to control natural gas, air, nitrogen, carbon dioxide, propane vapor and other non-corrosive gases.

Features (Low and Medium)

- Variety of interchangeable orifices
- Various connections sizes available in either 90° (right angle) or 180° (straight-flow) configurations
- Outlet pressures up to 30 PSIG

Features (High Pressure)

- Streamline Flow Path for quiet operation
- Sizes from 2" through 12"
- Compact Size and Light Weight
- Reversible sleeve
- Stainless Steel Valve Cages

Advantages

- Pressure reduction
- Relief valve
- Pressure reduction/monitor combination
- Two stage pressure reduction with monitor override
- Differential pressure drops up to 1000 PSID
- On/Off control of flow
- Underpressure shutoff
- Flow Control
- Check Valve



Low, Medium and High Pressure Regulators

Elster American Meter pressure regulators are used either upstream of a gas meter to reduce inlet pressure to the meter thereby eliminating fluctuations which can affect meter accuracy, or downstream of the gas meter to provide reduced pressure for gas-operated equipment.

Elster American Meter offers different regulator models that include options for protection against over and underpressure conditions. The most common of these options include:

- Internal relief (partial or full) - the ability to vent excess gas to atmosphere in the event the outlet pressure rises above a predetermined value.
- Overpressure shut-off (OPSO) - the ability to shutoff the gas supply if outlet pressure exceeds a predetermined value.
- Under pressure shut-off (UPSO) - the ability to shutoff the gas flow if the inlet pressure is disrupted.
- Remote sensing - the ability to control/monitor pressure at a specified location downstream of the regulator.
- Universal Safety Shutoff Assembly (USSA) - the ability to shutoff the gas flow if the outlet pressure exceeds or falls below a predetermined value.



Selecting the Correct Pressure Regulator

The three major factors that determine the selection of a pressure regulator are as follows:

- Inlet pressure to the regulator (minimum and maximum)
- Outlet pressure that the regulator must maintain
- Required capacity of the regulator in SCFH (Sm^3/h)

Elster American Meter offers a wide variety of regulators to meet almost any application as shown in the charts to the right.

Maximum Inlet Pressure Ratings

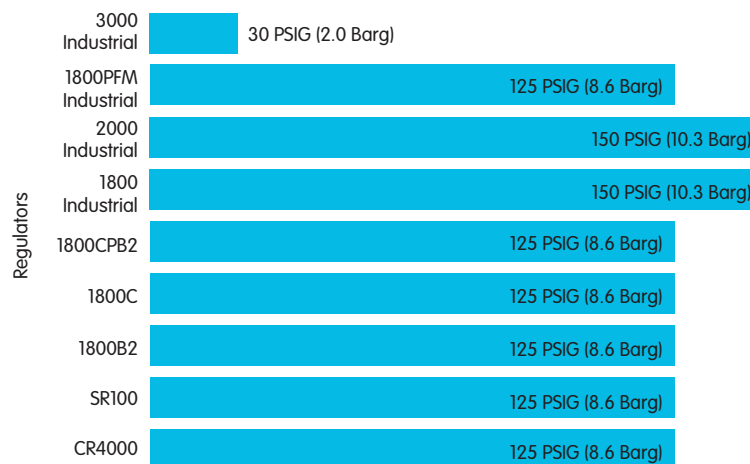

Maximum Rated Capacities

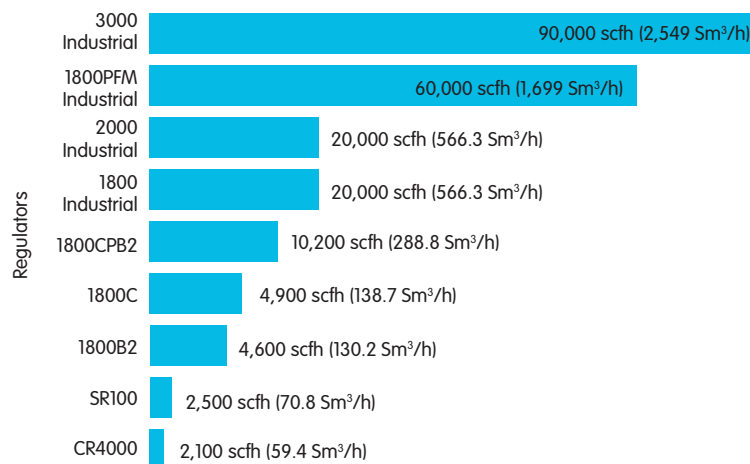

Outlet Pressure Range

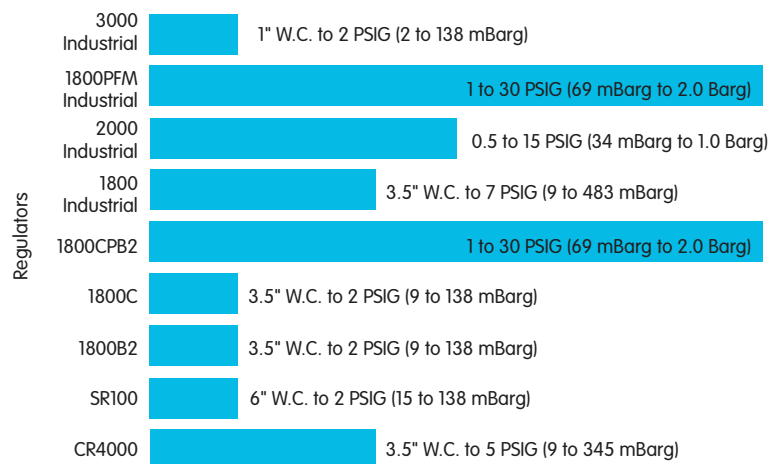

Low and Medium Pressure Regulators

Each series of low and medium pressure regulators offer various combinations of inlet/outlet pressure ranges and maximum capacities. Elster American Meter has various medium-pressure regulators to fit your need.



J48 Series Regulators

- Type: direct-acting, spring-loaded
- Maximum rated capacity: 28040 SCFH (800 Sm³/h)
- Maximum inlet pressure: 5 PSIG (350 mBarg)
- Outlet pressure range: 2" to 64" W.C. (5 to 160 mBarg)
- Connection sizes: 3/4", 1", 1-1/4", 1-1/2", 2" & 3" NPT
- Available options: Vent restrictor



J78RS Series Regulators

- Type: direct-acting, spring-loaded
- Maximum rated capacity: 2400 SCFH (68 Sm³/h)
- Maximum inlet pressure: 5 PSIG (350 mBarg)
- Outlet pressure range: .8" to 19.3" W.C. (2 to 48 mBarg)
- Connection sizes: 1/2", 3/4" and 1" NPT
- Available options: Vent restrictor



Series CR4000 Regulators

- Type: lever-type, spring-loaded
- Maximum rated capacity: 2,100 SCFH (59.4 Sm³/h)
- Maximum inlet pressure: 125 PSIG (8.6 Barg)
- Outlet pressure range: 3.5" W.C. to 5 PSIG (9 to 345 mBarg)
- Connection sizes: 3/4" and 1" NPT or BSP-TR
- Available options: full internal relief



SR100 Series Regulators

- Type: lever-type, spring-loaded
- Maximum rated capacity: 2500 SCFH (71 Sm³/h)
- Maximum inlet pressure: 125 PSIG (8.6 Barg)
- Outlet pressure range: 2 PSIG (138 mbar)
- Connection sizes: 3/4", 1" NPT or BSP-TR

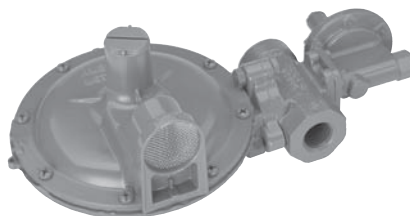

1800B2/1800B2-HC Series Regulators

- Type: lever-type, spring-loaded
- Maximum rated capacity: 4600 SCFH (130 Sm³/h)
- Maximum inlet pressure: 125 PSIG (8.6 Barg)
- Outlet pressure range: 3.5" W.C. to 2 PSIG (9 to 138 mBarg)
- Connection sizes: 3/4", 1" or 1-1/4" NPT or BSP-TR
- Available options: full internal relief, partial internal relief, OPSO, UPSO, USSA



1800C/1800C-HC Series Regulators

- Type: lever-type, spring-loaded
- Maximum rated capacity: 4,900 SCFH (139 Sm³/h)
- Maximum inlet pressure: 125 PSIG (8.6 Barg)
- Outlet pressure range: 3.5" W.C. to 2 PSIG (9 to 138 mBarg)
- Connection sizes: 3/4", 1" or 1-1/4" NPT or BSP-TR
- Available options: full internal relief, OPSO, UPSO, USSA



1800CPB2 Series Pilot-Loaded Regulators

- Type: lever-type, pilot-loaded
- Maximum rated capacity: 10,200 SCFH (289 Sm³/h)
- Maximum inlet pressure: 125 PSIG (8.6 Barg)
- Outlet pressure range: 1 to 30 PSIG (69 mBarg to 2.0 Barg)
- Connection sizes: 3/4", 1" or 1-1/4" NPT or BSP-TR
- Available options: OPSO



1800 Series Industrial Regulators

- Type: lever-type, spring-loaded
- Maximum rated capacity: 20,000 SCFH (566 Sm³/h)
- Maximum inlet pressure: 150 PSIG (10.3 Barg)
- Outlet pressure range: 3.5" W.C. to 7 PSIG (9 to 483 mBarg)
- Connection sizes: 1-1/2" or 2" NPT/BSP-TR, 2" flanged
- Available options: full internal relief, partial internal relief, OPSO, UPSO, USSA, external sensing



1800PFM Series Industrial Regulators

- Type: lever-type, pilot-loaded
- Maximum rated capacity: 60,000 SCFH (1,699 Sm³/h)
- Maximum inlet pressure: 125 PSIG (10.3 Barg)
- Outlet pressure range: 1 to 30 PSIG (69 mBarg to 2.0 Barg)
- Connection sizes: 1-1/2" to 2" NPT/BSP-TR, 2" flanged
- Available options: OPSO, USSA, external sensing



2000 Series Industrial Regulators

- Type: lever-type, spring-loaded
- Maximum rated capacity: 20,000 SCFH (566 Sm³/h)
- Maximum inlet pressure: 150 PSIG (10.3 Barg)
- Outlet pressure range: 0.5 to 15 PSIG (34 mBarg to 1.0 Barg)
- Connection sizes: 1-1/2" or 2" NPT/BSP-TR, 2" flanged
- Available options: OPSO, UPSO, USSA, external sensing



Series 3000 Industrial Regulators

- Type: direct-acting, spring-loaded
- Maximum rated capacity: 90,000 SCFH (2,549 Sm³/h)
- Maximum inlet pressure: 30 PSIG (2.0 Barg)
- Outlet pressure range 1" W.C. to 2 PSIG (2 to 138 mBarg)
- Connection sizes: 1-1/4", 1-1/2" or 2" NPT/BSP-TR, 2", 3" or 4" flanged
- Available options: external sensing

High Pressure Regulators

Axial Flow Valves

The Axial Flow Valve (AFV) utilizes a durable flexible element that opens or closes the valve dependent upon the differential pressure across it. Integral to the main valve is a pilot that controls the differential pressure across the flexible element by sensing downstream demand (or upstream pressure in relief/backpressure mode). This unique design allows the AFV to be extremely versatile and work in a variety of applications. The most common applications are:

- Pressure regulation
 - Single-stage pressure reduction
 - Two-stage pressure reduction
 - Pressure reduction with monitor used for overpressure protection
 - Two-stage pressure reduction with monitor override (working monitor)
- Overpressure relief/backpressure
- Underpressure shutoff
- Flow control
- On/off valve

Principle of Operation

The Axial Flow Valve is unique in that there is no mechanical connection to the control element. Instead, the valve uses an elastomer sleeve or diaphragm, which expands or contracts depending on the pressure differential across the valve. This principle provides a valve that is extremely compact and lightweight with a streamlined flow path for quiet operation.

Standard flexible element materials provide a wide working temperature range and excellent resistance to abrasion and swelling. Specialized materials are also available for applications involving extreme temperatures, where additional chemical resistance is required, and for specialized services such as water scarfing.

Control Pilots

Various spring-loaded pilot regulators can be utilized to balance the pressure applied to the control port of the Axial Flow Valve. It is actually the choice of pilot that determines the function (pressure reduction or backpressure) and outlet pressure or relief setting.



Axial Flow Valve with 60 Series Pilot



Z Pilot

- Z – Low pressure, (1 - 325 PSIG) pressure reducing
- Z-138 – High pressure, (150 - 600 PSIG) pressure reducing
- ZSC-100 – Low pressure, (1 - 325 PSIG) pressure reducing, secondary sense port
- ZSC-320-100 – High pressure, (150 - 600 PSIG) pressure reducing, secondary sense port
- ZSC-150 – Low pressure, (1 - 325 PSIG) relief service, secondary sense port
- ZSC-320-150 – High pressure, (150 - 600 PSIG) relief service, secondary sense port



60 Series Pilot

- 60L-PR – Low pressure (3 – 325 PSIG) pressure reducing
- 60L-RV – Low pressure (3 – 325 PSIG) relief service
- 60H-PR – High pressure (250-900 PSIG) pressure reducing
- 60H-RV – High pressure (250 – 900 PSIG) relief service



1203 Pilot

- 1203 – Low pressure, (6" W.C. – 6 PSIG) pressure reducing

Meter and Regulator Accessories

Elster Gas Depot™ offers various meter and regulator accessories for use in a wide variety of gas measurement and control applications.



Needle Valves

Needle valves are used for applications such as orifice meter gauge line connections, shut-off valves for pressure gauges, odorizers, sampling devices and other high-pressure control applications. Elster American Meter needle-valve bodies are constructed of stainless steel (with electro-polish finish) or carbon steel (with nickel-plated finish) bar stock. These high-pressure valves are rated for 10,000 PSIG at 200°F and utilize a chemical resistant viton o-ring and Teflon back-up ring.



Lubrication

Meters require routine maintenance, including lubrication, to insure measurement accuracy and enhance the service life of the meter. Two types of lubrication pump kits are available depending on the working pressure of the meter. For meters operating up to 500 PSIG, a plunger-type pump is available (Part Number 93723K002). For meters operating over 500 PSIG, use the single speed hydraulic hand pump (Part Number 93723K001).



Regulator Vent Splashguards

When regulator vents freeze over, the top diaphragm chamber may be prevented from breathing resulting in high fluctuations in outlet pressures. The use of Elster American Meter splashguards is a quick and simple solution to this problem and assures constant and reliable gas service.



Straightening Vanes

Swirl is a condition where the gas velocity is not totally parallel to the axis of the pipe but has a spiral component. It may be caused by complex piping, control and/or shutoff valves, elbows or other fittings in the meter/regulator station.

Swirl in the direction of the rotor rotation will cause a turbine meter to over-register and vice-versa for swirl in the opposite direction of the rotor. Elster American Meter Straightening Vanes straighten the gas flow to a normal pattern, enabling accurate measurement by the downstream turbine meter.

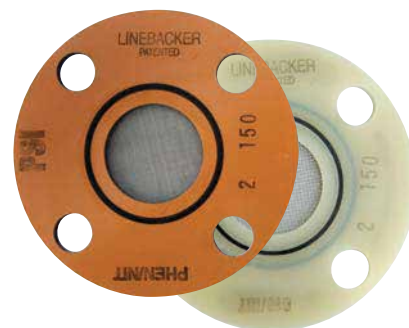

Gasket Strainers

Gasket Strainers are an effective way to protect downstream metering and regulation equipment from weld slag and other debris in the gas stream.



Remote Volume Pulsers

The RVP pulser provides a dry-contact switch closure from a magnetic reed switch during each revolution of the meter index drive. The RVP-FI Pulser is installed over the meter index drive using the holes in the meter body used for the index box. The existing index and index box become part of the Pulser Assembly during installation. Contact closure is supplied by normally open Form A switch. The output of the switch is available through an integral 12-foot cable. The cable also includes access to a loop for floating tamper detection circuits as well as a connection to the common when needed for tamper detection.

Safety Shutoff Devices

Overpressure shutoff valves are typically placed upstream of a pressure regulator. In the event of a regulator failure, these units provide rapid automatic and positive shutoff of gas service, protecting the regulator, meter and other downstream equipment.

- 1 Overpressure shutoff valve
- 2 Sensing line
- 3 Regulator

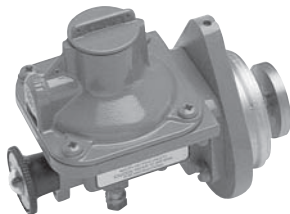
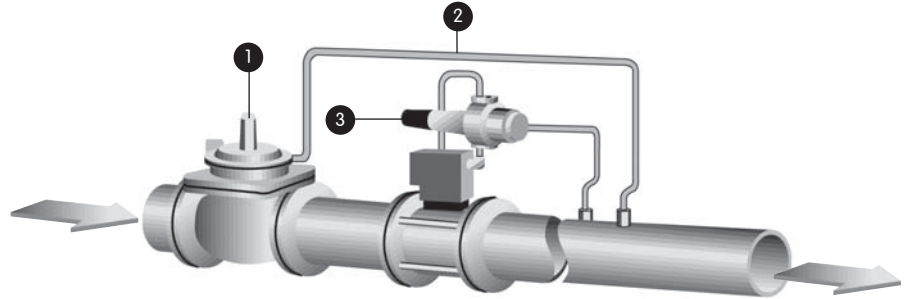

Universal Safety Shutoff Assembly (USSA)

- Maximum inlet pressure: 150 PSIG (10.3 Barg)
- OPSO shutoff pressure range: 7.5" W.C. to 58 PSIG (19 mBarg to 4 Barg)
- UPSO shutoff pressure range: 3" to 60" W.C. (7 mBarg to 149 mBarg)
- Connection sizes: 1-1/2" or 2" NPT/BSP-TR; 2" flanged
- Available options: overpressure shutoff (OPSO), underpressure shutoff (UPSS), Over/underpressure shutoff (OUPS). External sensing optional.



Series 100 Slam Shut

- Maximum inlet pressure: 235 PSIG (16.2 Barg)
- OPSO shutoff pressure range: 14" W.C. to 87 PSIG (35 mBarg to 6.0 Barg)
- Connection sizes: 2", 3" or 4" flanged

Filters

Elster American Meter filters effectively remove dirt, pipe scale and other particulate from gas lines, protecting meters, regulators and downstream gas equipment. Filters with either screwed or flanged connections for medium to high flow rates are available to meet nearly any gas filtrating application. In addition, pilot-type filters are available for protection of pilot-loaded regulators where particulate can cause variances in system pressures.



Screwed Filters

- Maximum inlet pressure: 160 PSIG (11 Barg)
- Filter element: 5 micron
- Connection sizes: 3/4", 1", 1-1/2" or 2" NPT/BSP-TR



Pilot-Type Filters

- Maximum inlet pressure: 1,000 PSIG (69 Barg)
- Filter element: 5 micron
- Connection sizes: 1/4" x 90° or 1/4" x 180°



Flanged Filters

- Maximum inlet pressure: 1,480 PSIG (99.2 Barg)
- Filter element: 10 (standard) or 25 micron
- Connection sizes: 2" NPT, 2", 3", 4", 6", 8", 10" or 12" flanged
- Special designs available upon request

Prefabricated Meter Set Assemblies

Elster Perfection's prefabricated products allow utilities to implement more uniform standards for all their meter set installations.

For years, installation crews have invested significant time fabricating meter sets in the field. Today, more and more utilities recognize they can improve the productivity of their field crews and the appearance of the finished product by using Elster Perfection prefabricated meter sets.

Our precision fabricated products allow you to simplify meter set installations, saving time and money. Elster Perfection prefabricated meter sets reduce the number of threaded joints required to complete an installation... saving time, improving safety, and prolonging service life by eliminating potential leak points.

Standard Meter Set Configurations and Installation Components

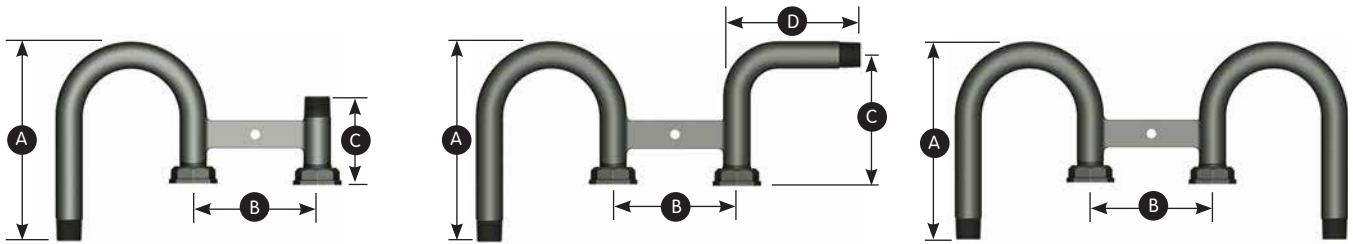

Style "A" - Straight Outlet

Inlet A	Flange B	Flange C	Outlet D	Part #
3/4" NPT	10 LT	10 LT	3/4" NPT	34584
3/4" NPT	Spr 1A	Spr 1A	1" NPT	34585
3/4" NPT	1" 20 LT	1" 20 LT	1" NPT	34586
1" NPT	20 LT	20 LT	1" NPT	34587
3/4" NPT	Spr 1A	Spr 1A	1" NPT	34588
1" NPT	1-1/4 Pitts	1-1/4 Pitts	1" NPT	34589

A	B	C
9"	6"	5"
228.6 mm	152.4 mm	127.0 mm

Style "B" - 90° Outlet

Inlet A	Flange B	Flange C	Outlet D	Part #
3/4" NPT	10 LT	10 LT	3/4" NPT	34590
3/4" NPT	Spr 1A	Spr 1A	1" NPT	34591
3/4" NPT	1" 20 LT	1" 20 LT	1" NPT	34592
1" NPT	20 LT	20 LT	1" NPT	34593
1" NPT	Spr 1A	Spr 1A	1" NPT	34594
1" NPT	1-1/4 Pitts	1-1/4 Pitts	1" NPT	34595

A	B	C	D
9"	6"	5-1/2"	5-1/2"
228.6 mm	152.4 mm	139.7 mm	139.7 mm

Style "C" - 180° Outlet

Inlet A	Flange B	Flange C	Outlet D	Part #
3/4" NPT	10 LT	10 LT	3/4" NPT	34610
3/4" NPT	Spr 1A	Spr 1A	1" NPT	34611
3/4" NPT	1" 20 LT	1" 20 LT	1" NPT	34612
1" NPT	20 LT	20 LT	1" NPT	34613
1" NPT	Spr 1A	Spr 1A	1" NPT	34614
1" NPT	1-1/4 Pitts	1-1/4 Pitts	1" NPT	34615

A	B
9"	6"
228.6 mm	152.4 mm

E-coat/Polyester is standard coating. Specifications available upon request. For styles B and C, offset outlets can be specified.



Meter Ells and Loops

Elster Perfection's prebent meter loop potentially eliminates four joints and our meter ell eliminates two joints. These products can be supplied threaded or with formed-end swivels and swivel nuts to match up perfectly to your meter.



Multiple-Meter Manifolds

Elster Perfection's prefabricated multiple-meter manifold makes installation easy and greatly reduces the number of threaded joints. From two drops (meters) up to 10 drops, we have the product to meet your requirements.

Elster Perfection Coating Options

Elster Perfection's standard coating is polyester over E-coat paint. This superior coating combination provides not only UV protection but impact protection as well. Meter sets and manifolds can also be shipped coated with epoxy powder, zinc plating or painted coatings to your specifications.

Repair & Refurbish and Metrology Services

Refurbishing

The Refurbishing program refers to all brands of meters that are less than 20 years old and includes various processes like the Internal Leak Test, Pressure Wash, General "Above the Table" Clean Up, Index Test, Inspection and Lubrication, Proving, Prime and Finish Paint and more.

Refurbish Plus

The Refurbish Plus program refers to all brands of meters that are less than 30 years old. The program contains all services included in Refurbish, plus additional replacement parts and services such as Pressure Testing at Badged Maximum Pressure.

Reverify/Adjust

The Reverify/Adjust program provides the customer with a standard process similar to "Pass Thru" utility processes that confirms the measurement and pressure integrity of the meter.

Meters qualify for Reverify only if intest results are within +/- 1.0% with a spread not to exceed 1%. Meters with intest results within +/- 2.0% with a spread not to exceed 1% are candidates for Reverify and Adjust.

Metrology Services

When sufficient vacuum is applied to a sonic nozzle it creates a constant flow rate. Bernoulli's principle is applied to calculate various flow rates chosen by the user, and the metrology process is automated by a computer or PAC system. Our sonic nozzle provers are capable of displaying not only meter proofs to a user, but are also capable of transmitting proofs as well as other important data to database systems across a computer network.

Our Metrology Group also designs and provides new SNAP provers, upgrades and large Universal customer designed sonic nozzle provers and test equipment. Elster SNAP provers have become the North American standard for the accurate and reliable proving of natural gas meters.

Field Services and Training

Elster Meter Services offers an extensive field service and training portfolio for both the Upstream and Downstream markets.

Through our programs and in conjunction with our strategic partners Elster services includes on site verification of metering and regulation systems, AMR / AMI installs, meter change-outs, system start ups, measurement upgrades and related services.

In addition, Elster can offer training programs tailored to customer-specific needs. Programs can be delivered at site or at Elster facilities and can range from fundamentals to advanced measurement and regulation needs.

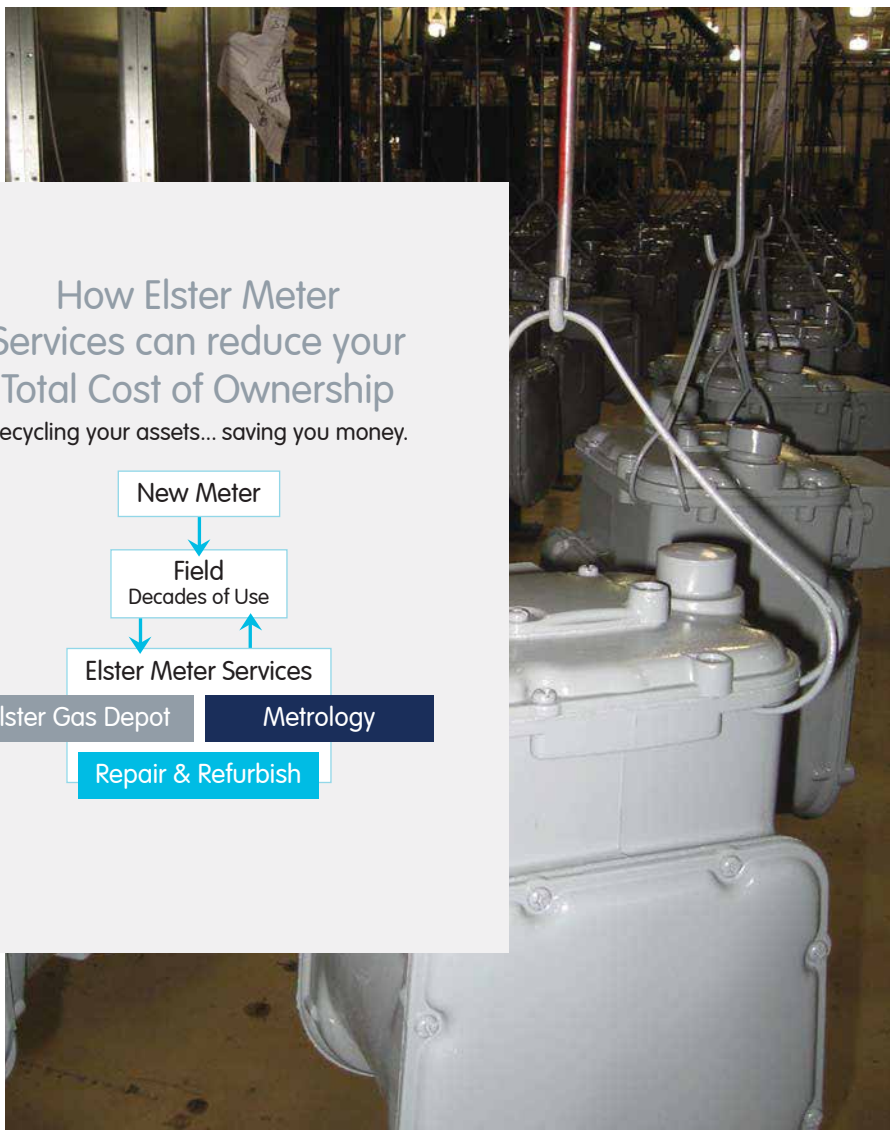

How Elster Meter Services can reduce your Total Cost of Ownership

Recycling your assets... saving you money.

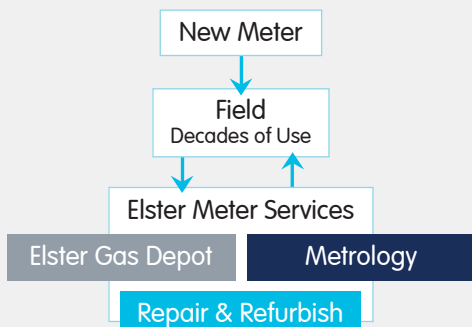

Automated Meter Reading/Advanced Metering Infrastructure

At Elster we understand that choosing an AMR/AMI communications solutions partner is an important decision for you and your utility, and that it is critical for you to work with a company that doesn't just pursue excellence, but delivers it. Every day.

That is why electric, gas and water utilities worldwide trust Elster to analyze, design, engineer, deploy and support their AMI systems. Elster delivers proven single and multi-utility solutions that automatically satisfy utility needs today and are future-proofed for tomorrow.

When you partner with Elster, we ensure AMI success through our unique abilities:

- Assemble a comprehensive end-to-end solution to meet your AMR/AMI project objectives.
- Integrate our proven RF communications systems with any legacy and enterprise platform.
- Partner with third party software and hardware companies to bring best in class solutions to our utility customers.
- Deliver turnkey services and solutions.
- Mitigate risk throughout the entire process.

When it comes to smart meters, advanced meter reading, demand response, outage management, in-home solutions or any other component critical to your ultimate solution, Elster - with our global experience and solid financial power - is the only choice you can trust to bring together the best of the best.

EnergyAxis®

The Most Widely Deployed Multi-Utility or Single Utility Solution Available

EnergyAxis is an advanced metering infrastructure (AMI) solution that provides utilities with the tools and information needed to improve business operations and customer service, lower operating costs, and increase revenue and profits. Our sophisticated communication network is an intelligent, self-registering, self-healing, two-way controlled mesh solution for electric utilities, and also supports standalone gas and water utility applications. Our use of industry standards enables EnergyAxis to integrate seamlessly with your legacy or enterprise systems to provide unrivaled return on investment.

Elster's next generation of EnergyAxis gas and water modules will support migration from mobile to fixed network topologies, assuring that your AMR investment will be protected should you decide to implement a fixed network later.

This powerful solution offers the features you require including demand response, in-home solutions, remote connect/disconnect, outage detection and restoration notification, theft and leak detection, time-of-use metering, prepayment options, and many more functions.

EnergyAxis is the most widely deployed, two-way RF mesh network in the world. It has been proven effective in the most

densely populated cities and rural mountains, in extremes of heat, cold and humidity, and even when meters are deployed in basements and metal enclosures.

TRACE®

Cost Effective Gas-Only Solution

Elster's TRACE is an automated meter reading (AMR) system that uses two-way, RF communications to specify and collect gas meter data. The system includes transponders that process individual meter data and mobile interrogators that communicate with transponders to identify the required data, collect it from the transponder, and provide it to the route management software. TRACE efficiently processes and transfers meter data to your utility's customer information system (CIS) providing accurate billing information. Two-way communications enable TRACE to deliver more data more efficiently than typical AMR systems. Benefits include more detailed data and faster route completion.





About Elster Group

A world leader in advanced metering infrastructure, integrated metering, and utilization solutions to the gas, electricity and water industries. Elster's metering and system solutions reflect over 170 years of knowledge and experience in measuring precious resources and energy.

Elster provides solutions and advanced technologies to help utilities more easily, efficiently and reliably obtain and use advanced metering intelligence to improve customer service, enhance operational efficiency, and increase revenues. Elster's AMI solutions enable utilities to cost-effectively generate, deliver, manage, and conserve the life-essential resources of gas, electricity, and water.

Elster has a staff of over 7,500 serving customers globally in North America, Central America, South America, Europe, Asia, Africa and the Middle East.

Elster American Meter
2221 Industrial Road
Nebraska City, NE 68410
USA

T +1 402 873 8200
F +1 402 873 7616

www.elster-americanmeter.com

Elster Canadian Meter

T +1 905 634 4895
F +1 905 634 6705

www.elster-canadianmeter.com

© 2009 Elster American Meter. All rights reserved.

EnergyAxis®, Trace®, Gas Depot™ Trademarks of Elster

Petes Plug II® A trademark of the Peterson Equipment Company, Inc.

Information contained herein is subject to change without notice. Product specifications may change. Contact your Elster American Meter representative for the most current product information. Printed in the United States.

EAM-BR2100.4-EN-P - September 2009
Supersedes GPC 2100.3