



Operating and Maintenance Manual

IPS-H SERIES AUTOMATIC SHUT-OFF VALVE

Covering the 3/4", 1" and 2" Models

SS100 Book 1 Revision 3 04/03/1999





Operating and Maintenance Manual

Subject

IPS-H Series Automatic Shut-Off Valve

Manual Number	SS100 Book 1	Issue Date	04/03/1999
Revision	3	Page Number	1

Operating and Maintenance Manual IPS-H Series Automatic Shut-Off Valves

Visual Inspection

1. Make sure that the unit specified for the installation agrees with the actual product about to be installed.
2. Before installing the Security Valve, be certain that all applicable standards and codes have been reviewed and recommendations and requirements considered. The following instructions are given as the manufacturers recommended procedures for installation. Also, follow good accepted industry procedures for Security Valve installation and performance. Any conflicts with the procedure should be verified before changes are made.

Installation

1. Thoroughly purge the inlet piping to remove dirt and debris that could damage the Security Valve or impair its operation. If the installation is in a location where continual dirt problems are encountered a filter or strainer should be installed ahead of the Security Valve.

It is recommended that inlet and outlet Shut Off Valves be installed. It is also recommended that a Bypass Line with a Shut-Off Valve be installed to permit repair or replacement of the product.

2. Remove the shipping covers or screens from the connections, inlet and outlet etc., and make sure that the Security Valve is free of foreign matter or debris.
3. Install the Security Valve making sure that the body flow arrow is in the correct direction. High pressure connects to the inlet side. Apply thread sealing compound to the male pipe threads only.

On flanged connections make sure that the inlet and outlet piping flanges are properly aligned prior to installing the Regulator.

Tighten the flanges evenly and firmly and torque to British Standard recommendations.

4. The 1" screwed and 2" IPS-H flanged Security Valves may be installed in any position.

Start Up

1. All Shut Off Valves should be closed, (inlet, outlet and bypass).
2. Slowly open the Inlet Valve until the Security Valve is pressurised to the specified normal line pressure. Remove the latch lever shaft's cover cap and rotate the shaft anti-clockwise until re-latch occurs.

Note: In cases where the line pressure within the Valve Body equals or exceeds that in the following table, a piped bypass, with a normally closed manual Shut Off Valve, is necessary. This should be located between the up stream and down stream side of the Valve Disc to permit equalisation of pressure so that re-latching can be accomplished.

No bypass is necessary for operating pressures less than shown below

SIZE	OPERATING PRESSURE	RESET TORQUE
1" Screwed	10.3 Barg (150 psig)	4.3 Nm (3.2 ft/lbs)
2" Flanged	1.25 Barg (25 psig)	8.1 Nm (6.0 ft/lbs)

3. Check all connections for leakage.



Operating and Maintenance Manual

Subject

IPS-H Series Automatic Shut-Off Valve

Manual Number	SS100 Book 1	Issue Date	04/03/1999
Revision	3	Page Number	2

4. Make all necessary adjustments. The Security Valve adjustments are outlined in the Adjustments section below.
5. After the adjustments are completed check the unit's latch lever is still in the latched position. The arrow on the end of the latch lever indicates valve position. If the arrow is pointing perpendicular to the body flow arrow line the valve is closed. If the arrow is pointing parallel to the body flow arrow, then the valve is latched.
6. Put the IPS-H Series Security valve into service by opening the downstream valve and initiating operation of the receiving equipment.

Adjustments

1. The Security Valve is factory adjusted as specified by the order for set point. However, in the event that changes are necessary or desired the following procedure should be employed.
2. A pressure bypass may be required as noted by Procedure 3 Section (b) above to facilitate re-latching.
3. Set point
 - (a) If the new set point is higher than the pressure specified by the order, turn the adjustment clockwise until latching can be achieved by turning the latch lever shaft anti-clockwise. Increase the line pressure to achieve shut off noting the pressure. Decrease the inlet pressure to normal line pressure and re-latch the valve by turning the latch lever shaft anti-clockwise.
 - (b) If the new set point is lower than the pressure specified by the order, turn the adjustment anti-clockwise until shut off occurs noting the pressure. Decrease the inlet pressure to normal line pressure and re-latch the valve by turning the latch lever shaft anti-clockwise.

Shutdown

Prior to any repair or removal of the Security Valve, open the outlet valve, close the inlet valve and open the bypass valve and allow the system pressure to equalise. If a bypass valve is not fitted, make sure that the inlet pressure is equalise by removing the latch lever shaft's cover cap and turning the shaft anti-clockwise to an open position. The line should then be de-pressurised through an appropriate vent and the gas safely disposed of.

Information

1. These instructions are important to the operation of the Security Valve. They should be retained for future reference.
2. For additional information on spare parts and service do not hesitate to contact our service department on 01664 567797.

WARNING

If the IPS Series Security Valve activates (shuts off) while in service, then search out, locate and correct any system fault prior to re-activation



Subject

IPS-H Series Automatic Shut-Off Valve

Manual Number	SS100 Book 1	Issue Date	04/03/1999
Revision	3	Page Number	3

Materials of construction

Body:	Cast Steel or 2" only Ductile Iron	BS1504-161-480 GGG40
Diaphragm Case:	Machined Steel	BS970 Pt.3

Overhaul Instructions

- Make sure that the IPS Series security Valve is entirely depressurised before disassembling.
- In general it is not necessary to remove the security valve body from the pipeline, unless it is suspected that damage has occurred to the orifice. Otherwise all other maintenance can be undertaken with the body in-situ.
- To service the Security Valve, first turn the adjustment screw (2) anticlockwise to release the spring tension. Remove the eight bolts (27) to separate the diaphragm case from the Security Valve body. Care should be taken during the separation process to disengage the bobbin (17) from the actuator arm mechanism (37). A slight tilting of the assembly towards the inlet is required to disengage the bobbin from the actuator fork. The diaphragm chamber/spring housing assembly may now be disassembled.
- Carefully note the location of each part during disassembly to ensure accurate re-assembly. Replace all worn damaged or otherwise unsatisfactory parts.
- To simply change a spring (8) in-situ, remove the cover cap (1) and back-off the adjustment spring adjuster (2) to release the spring tension. Remove the threaded housing cover (6) and remove the upper spring button (10) and spring (8). When replacing the spring ensure that the lower spring button (11) is the correct way up and properly located. All other items should be re-assembled in the reverse order.
- To exchange the diaphragm (12) remove the diaphragm case assembly as described above. Unscrew the bobbin (17) and slide the diaphragm assembly through the stem gland (15). Separate the diaphragm assembly by unscrewing the bobbin shaft (14) from the nut (11). Replace the diaphragm as necessary and re-assemble.

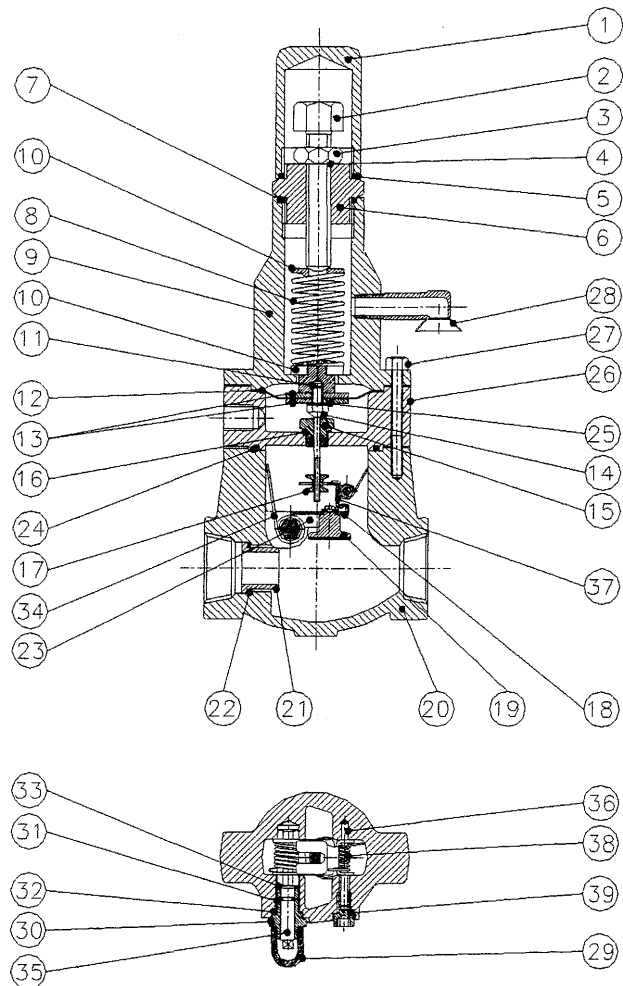

1" IPS-H Security Shut-Off Valve FIG 1

Use FIG 1 to identify recommended spare parts for 2" Models



Subject

IPS-H Series Automatic Shut-Off Valve

Manual Number	SS100 Book 1	Issue Date	04/03/1999
Revision	3	Page Number	4

- Before replacing the completed diaphragm case / Spring housing ensure that the bobbin is screwed onto the shaft so that the end of the shaft and base of the bobbin are flush. Replace the completed assembly being careful to capture the bobbin within the actuator arm fork. Line up the eight bolt holes, by inserting two bolts, and rotate the diaphragm clockwise, whilst attempting to re-latch the mechanism by operating the reset shaft (35). Once the mechanism re-latches solidly, line up the diaphragm holes with the nearest case holes and retest. Once successful, replace the spring chamber and secure as previously described.
- To replace the flap valve assembly (19 & 23) Remove the spring chamber / diaphragm case assemblies as previously described. Remove the plastic reset shaft cover (29) and unscrew the reset shaft gland (30) Pull the reset shaft through the body opening. The spring (34) and flap valve assembly will fall into the body cavity.
 - Replace parts as necessary. However it is highly recommended that both the Tetraseal (32) and thrust washer (31) are changed at every service. To re-assemble the new flap valve and spring a special tool may be purchased as an optional spare part. The spring is pre-tensioned on the tool whilst the reset shaft is replaced through the centre of the thrust washer, spring and flap valve arm. This operation should be undertaken with the flap valve in the closed position, i.e. covering the orifice and the shaft position indicator (on the end of the reset shaft) in a closed, vertical, position. The diaphragm case / spring housing assembly may then be re-fitted and the bobbin adjusted as previously described.
 - Should the orifice (21), or orifice seal (20), need replacement this is removed, by unscrewing through the Security Valve outlet pipeline connection. A new seal should always be fitted.

Recommended Spare Parts

Recommended Spare Parts Kit – use FIG 1 (for identification)

Suitable for ¾" & 1" IPS-H and DPS-H Security Valves

Kit No. RPP60 Comprising;

Item No.	Description.	Part No.	Quantity
4	Thread seal	999-100-001-506	1
5	O ring	BS/USA/025	1
7	O ring	BS/USA/123	1
12	Diaphragm	213-019-150-004	1
15	Stem gland & seal	NFC1001/10	1
16	Gasket	213-019-179-16	1
19	Valve & Disc arm assembly	210-019-411-006	1
22	Gasket	NFC1015/04	1
24	O ring	BS/USA/138	1
25	Gasket	NFC1015/05	1
31	O ring	BS/USA/010	1
32	Gasket	213-019-179-16	1
33	Teflon bearing	213-019-178-006	1
39	Gasket	NFC1015/05	1



Operating and Maintenance Manual

Subject

IPS-H Series Automatic Shut-Off Valve

Manual Number	SS100 Book 1	Issue Date	04/03/1999
Revision	3	Page Number	5

Recommended Spare Parts Kit – use FIG 1 (for identification)

For 2" IPS-H and DPS-H Security Valves

Kit No. RPP62 Comprising;

Item No.	Description.	Part No.	Quantity
4	Thread seal	999-100-001-506	1
5	O ring	BS/USA/025	1
7	O ring	BS/USA/123	1
12	Diaphragm	213-019-150-004	1
15	Stem gland & seal	NFC1001/10	1
16	Gasket	213-019-179-06V	1
19	Valve & Disc arm assembly	213-050-411-006	1
22	Gasket	NFC1014/02	1
24	O ring	BS/USA/138	1
25	Gasket	NFC1015/05	1
31	O ring	BS/USA/010	1
32	Gasket	213-019-179-16	1
33	Teflon bearing	213-019-178-006	1
39	Gasket	NFC1015/05	1