



SECURITY SHUT-OFF VALVES



INSTROMET SECURITY SHUT-OFF VALVES

GENERAL

The Instromet security shut-off valves are shut-off valves for the control of liquid or gases. Thousands of security shut-off valves have already been installed in gas distribution systems, factories, hospitals and public buildings, where they have served years with complete satisfaction and safety. The present line is the most precise and complete type that is available to industry today. In contrast to the great majority of shut-off valves currently on the market, the Instromet security shut-off valves are designed for application as an independent unit. They are engineered to perform a vital task in gas distribution. Standard models in a variety of types and designs are available, in sizes from $\frac{3}{4}$ " through 3", with shut-off ranges from just a few mbar up to 12.5 bar. Valves with even higher shut-off ranges, up to 50 bar, are also available on special request. Instromet security shut-off valves can be installed either upstream or downstream of a regulator or meter. They can be controlled directly or from a remote pressure source by means of an external control line. Instromet security shut-off valves are designed in strict accordance with the DIN or ANSI standards.

DESIGN

Dependability has been engineered into the complete line of Instromet security shut-off valves. The present design has evolved over many years of experience and guarantees long life and trouble-free operation. The resilience of the seating surface of the valve disc provides an optimized shut-off. The "O"-ring seal on the resetting shaft is incorporated to provide ease of resetting and a positive seal to

atmosphere. The "thru-flow" design permits installation of these valves in existing pipelines with negligible pressure drop. The latching mechanism is positive and floats with minor variations, preventing premature shut-off due to minor pressure fluctuations.

CONSTRUCTION

Instromet security shut-off valves are constructed of the finest materials available for each component. In standard models the

body is made of ductile iron. All internal components are made from aluminium, brass or stainless steel to minimize the effect of corrosion.

The seating surface of the valve disc is poly-U. The diaphragm is made from Buna-N.

The springs are either stainless steel or spring steel, heat treated. Valve bodies made from steel can be supplied on request. Special internal trims for chemical or corrosive gas service will also be quoted on request.

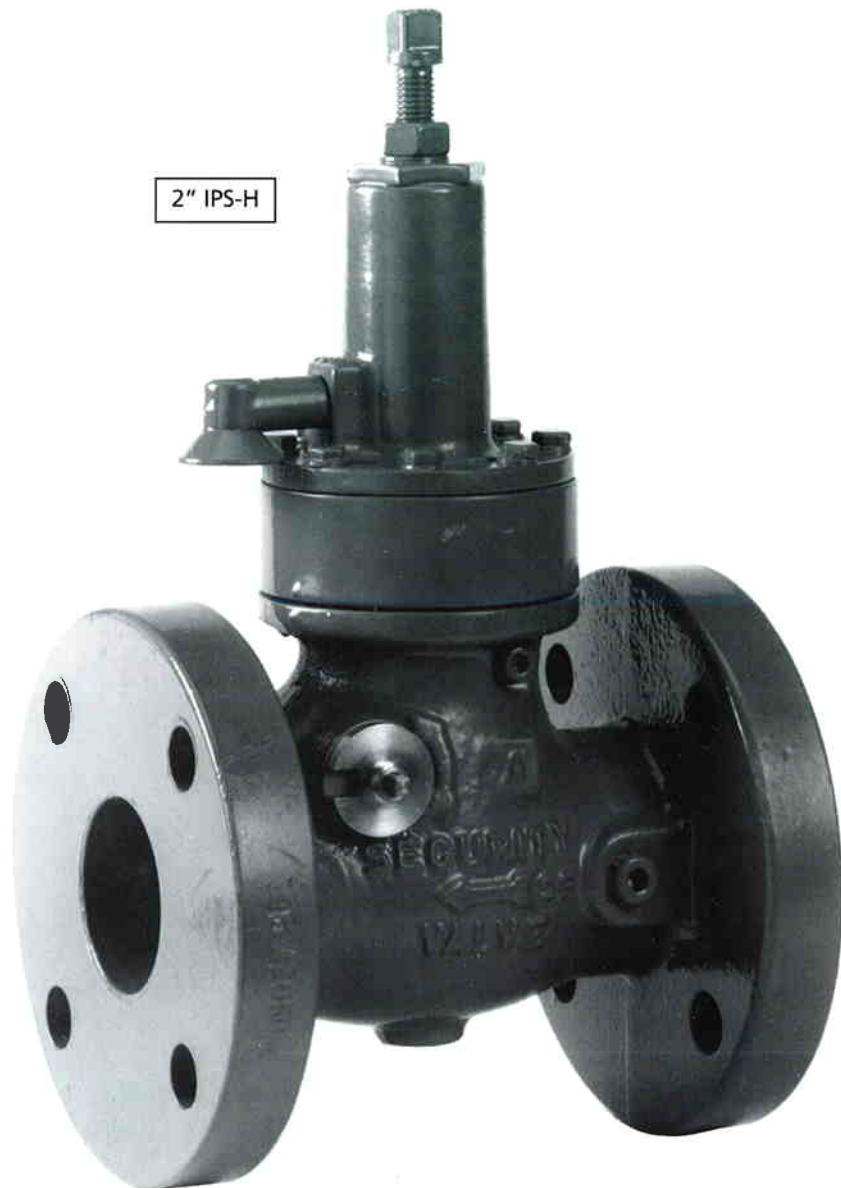

FUNCTION

Instromet security shut-off valves are either internally controlled or are controlled from an external control line. In the event of an increase or decrease in pressure, they will automatically shut-off at a specified preset value. This shut-off value, which should be specified with your order, is normally set at the manufacturer's but it can easily be readjusted in the field. If the pressure increases or decreases to the preset shut-off pressure - depending on the model of valve - the latch lever attached to the spring loaded diaphragm linkage assembly disengages from the valve disc arm. The spring loaded valve disc snaps automatically, and can only be reset manually.

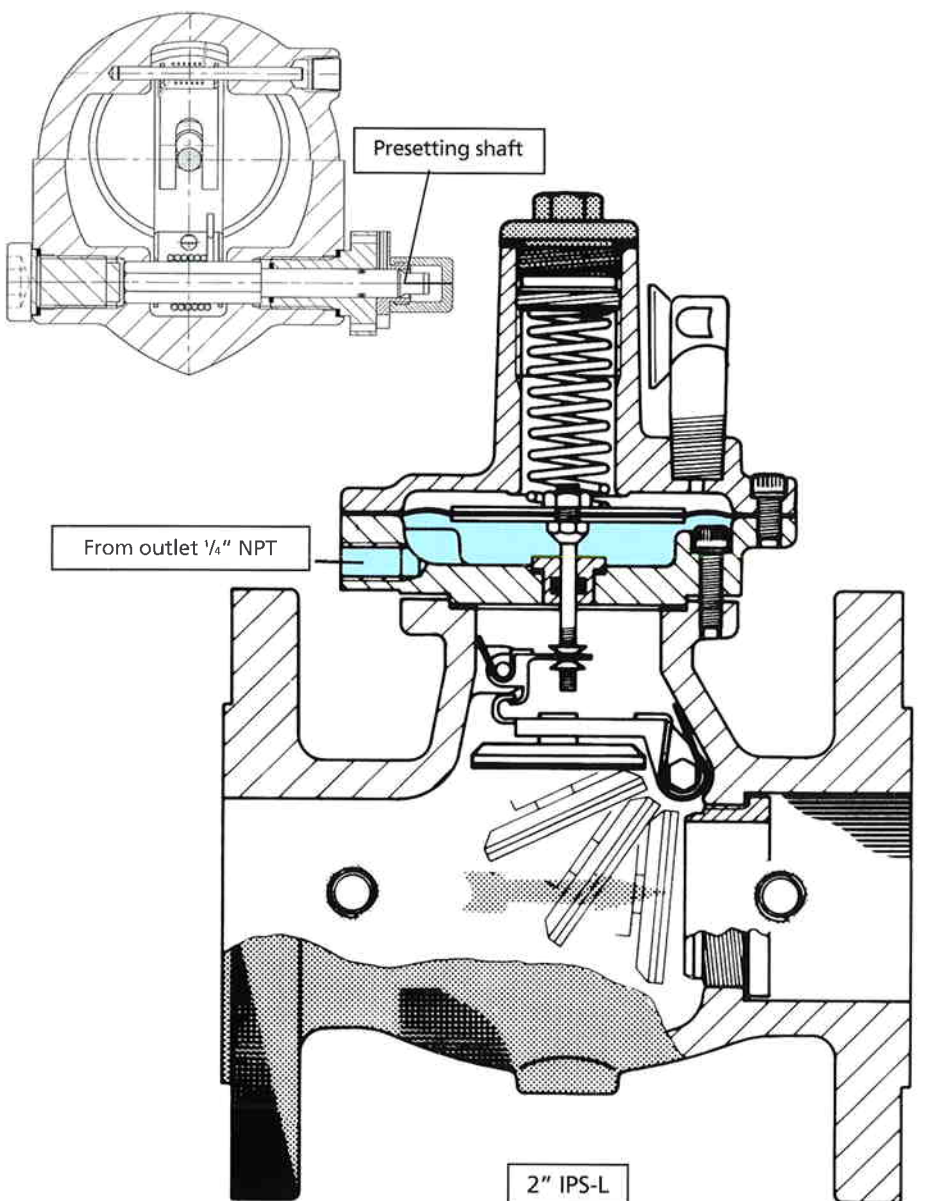

APPLICATIONS

OVERPRESSURE PROTECTION

For many years gas distribution companies have studied various means of controlling overpressure.

Three approved methods are:

1. shut-off valves;
2. monitoring regulators;
3. relief valves.

UNDERPRESSURE PROTECTION

Safety engineers are aware of the hazards which can occur in the case of fractured or leaking gas lines in factories and building. In many plants, we see that lines run overhead, underground and through walls. In case of break or failure, it may not be possible to trace the line to the manual shut-off valve, or its location may not be accessible to the person discovering the leak.

The pressure drop caused by leakage may be caused by leakage, line break, freezing or breakdown of regulator or other equipment.

ADVANTAGES OF THE SHUT-OFF VALVE

1. Shut-off valves are relatively small and therefore require little space.
2. Shut-off valves are simple to install and can easily be fitted into existing facilities.
3. Complete shut-off avoids the problem of escaping gas released by relief devices.
4. Maintenance cost of shut-off valves is considerably lower than on comparable monitoring regulators or relief valves.

SPECIAL TYPES

HIGH PRESSURE PISTON ACTUATED VALVES

Many applications require the use of shut-off valves for shut-off ranges which cannot normally be standard models with a spring loaded diaphragm assembly. In order to meet this demand, Instromet security shut-off valves are available with a piston actuated assembly instead of the standard diaphragm assembly, thereby extending the shut-off range to 50 bar. The piston actuating assembly can be incorporated into overpressure or underpressure shut-off models. The operation of the piston actuated valve is the same as the standard model.

- shut-off valves with remote signalling
- shut-off valves with stainless steel internal trims.

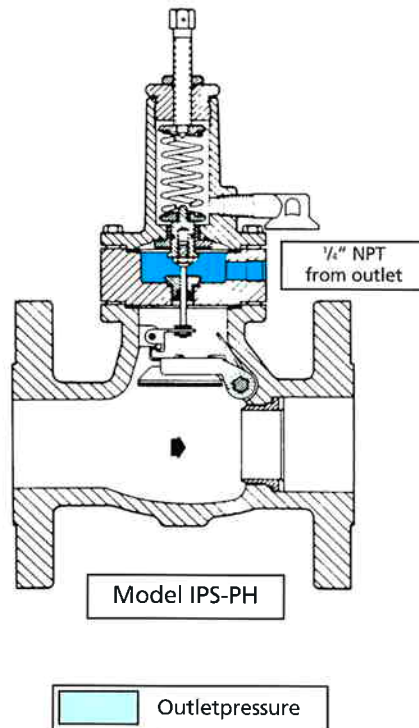

FEATURES

1. COMPLETE LINE

Many possibilities as to sizes, working pressures or shut-off ranges.

- sizes 1" to 3" (larger sizes on request);
- working pressures up to 100 bar;
- shut-off ranges up to 50 bar.

2. INSTALLATION

They may be installed at any point in the line.

3. POSITIVE ACTION

Specially designed to perform a single task, not a remodelled version of a regulator or a valve.

- does not vent to atmosphere;
- bubble tight shut-off;
- no border-line leakage;
- will not fluctuate on and off.

4. NO MAGNETS

Shut-off valves contain no magnets or other parts which may collect material thereby obstructing flow or affecting operation.

MODEL NUMBER INDEX

APPLICATION	MODEL	SHUT-OFF FUNCTION	MEANS OF ACTUATION	SIZE AND CONNECTIONS	SHUT-OFF RANGE
INCREASED PRESSURE CLOSING VALVE	IP-L	Increase pressure internal control	Diaphragm and spring	1" screwed	5 - 750 mbar
	IPS-L	Increase pressure external control	Diaphragm and spring	2"-3" flanged	5-750 mbar
	IP-H	Increase pressure internal control	Diaphragm and spring	1" screwed	0.42 - 12.5 bar
	IPS-H	increase pressure external control	Diaphragm and spring	2"-3" flanged	0.42 -12.5 bar
	IPS-PH	increase pressure external control	Piston and spring	1" screwed 2" flanged	max. 50 bar
DECREASED PRESSURE CLOSING VALVE	DP-L	Decrease pressure internal control	Diaphragm and spring	1" screwed	5-750 mbar
	DPS-L	Decrease pressure external control	Diaphragm and spring	2"-3" flanged	5-750 mbar
	DP-H	Decrease pressure internal control	Diaphragm and spring	1" screwed	0.42 - 12.5 bar
	DPS-H	Decrease pressure external control	Diaphragm and spring	2"-3" flanged	0.42-12.5 bar

DIMENSIONS AND WEIGHTS

CONNECTION	A	B
1" screwed NPT	108	35
2" flanged ANSI 150	178	84
2" flanged ANSI 250	190	84
2" flanged ANSI 300	190	84
2" flanged PN 10/16	188	84
2" flanged PN 25	190	84
3" flanged ANSI 150	241	98
3" flanged PN 16/25	254	98

Model		WEIGHTS IN KG		
		Screwed	Flanged	
		1"	2"	3"
IP-L	DP-L	2.5	9.5	19
IPS-L	DPS-L	2.5	9.5	19
IP-H	DP-H	2.5	9.5	19
IPS-H	DPS-H	2.5	9.5	19

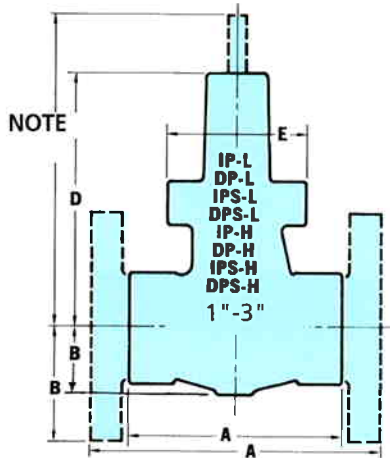

CONNECTION	D	D	D	D	E	E
	IP-L DP-L	IPS-L DPS-L	IP-H DP-H	IPS-H DPS-H -L(diam.)	All models -H(diam.)	All models
1"	135	135	195	195	122	92
2"	185	185	260	260	122	92
3"	235	235	289	290	122	92

Note: If the adjusting screw is removed, for dimension D 38 mm must be added for models IP-H, DP-H, IPS-H and DPS-H.

SHUT-OFF RANGES

MODELS IPS-L, IP-L, DPS-L, DP-L

Shut-off ranges	Colour	Part No.
15 - 15 mbar	Brown	210-019-021-304
15 - 35 mbar	Red	210-019-021-314
18 - 50 mbar	Green	210-019-021-324
33 - 75 mbar	Yellow	210-019-021-334
50 - 110 mbar	Grey-Black	210-019-021-364
85 - 240 mbar	Blue	210-019-021-344
185 - 600 mbar	Green-black	210-019-021-394
375 - 750 mbar	White-black	210-019-021-404

MODELS IPS-H, IP-H, DPS-H, DP-H

Shut-off ranges	Colour	Part No.
0.42 - 1.20 bar	Red-black	210-019-021-384
0.91 - 2.11 bar	Green-black	210-019-021-394
1.78 - 3.52 bar	White-black	210-019-021-404
2.46 - 4.22 bar	Orange-black	210-019-021-414
3.16 - 4.57 bar	Yellow-black	210-019-021-424
4.57 - 7.03 bar	Blue-black	210-019-021-434
6.33 - 12.50 bar	Brown-black	210-019-021-444

NOTES:

- switching time after pressure exceedance < 2 sec.
- shut-off pressures up to 50 bar available (see page 4).
- the control pressure of internally controlled valves (DP-L, DP-H, IP-L and IP-H) is equal to the pressure in the valve casing (line pressure).
- standard temperature range from -20° to +60° C.
- maximum allowed velocity in the valve casing not higher than 60 m/sec.

FORMULAE FOR CALCULATING FLOW RATE AND PRESSURE LOSS

1" SCREWED CONNECTIONS

DIAMETER	ORIFICE	K-FACTOR
1"	16.76 mm	490

2"-3" FLANGED CONNECTIONS

DIAMETER	ORIFICE	K-FACTOR
2"	40.64 mm	2850
3"	65.78 mm	8820

The following formulae can be used for:

a. calculating the capacity

$$Q = K \sqrt{P_u (P_l - P_u)}$$

b. pressure loss

$$P_l - P_u = \left(\frac{Q}{K}\right)^2 \times \frac{1}{P_u}$$

Q = capacity in m³/h

P_l = inlet pressure in bar absolute

P_u = outlet pressure in bar absolute

K = flow constant (see table opposite)

PRESSURE LOSS CURVE

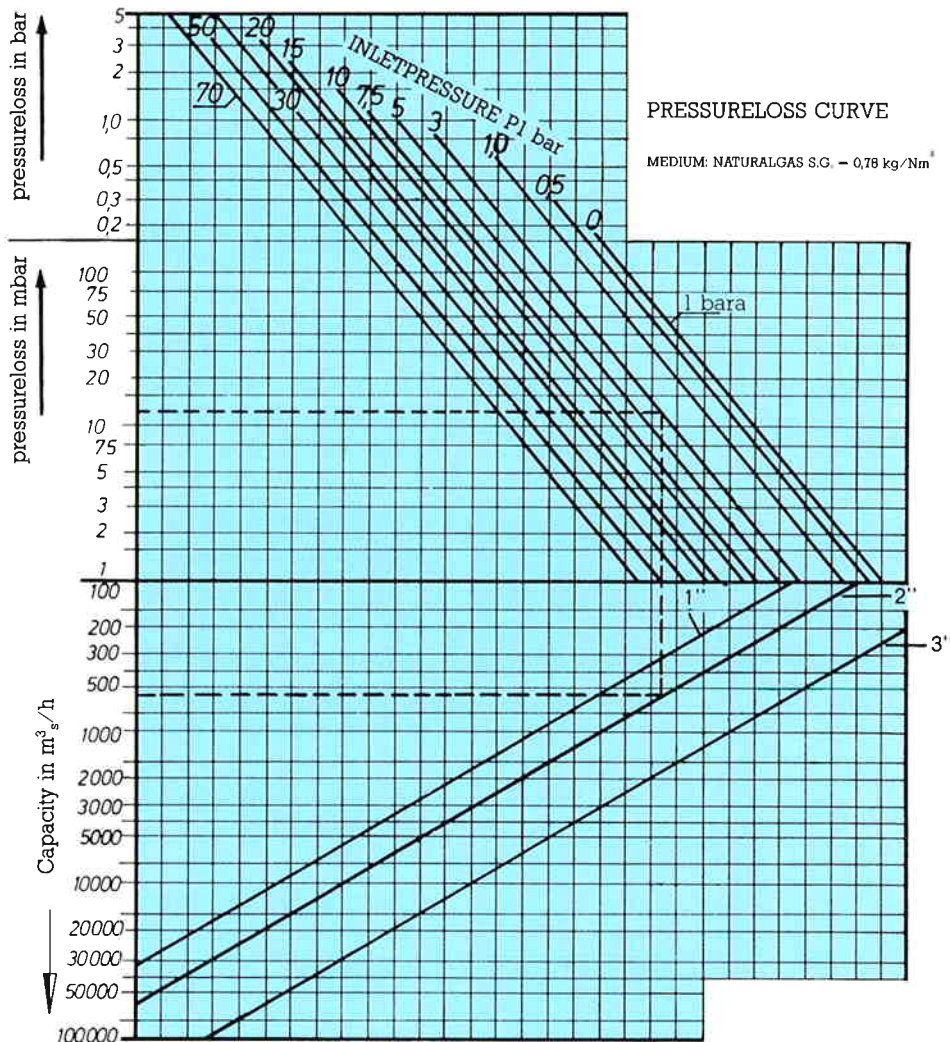

EXAMPLE:

Capacity Q = 600 m³/h of natural gas

Working pressure: 3 bar

Shut-off valve used: 2"

From the table there follows a pressure loss of 12 mbar (see dotted line)

CONVERSION FOR OTHER GASES

The capacity Q (taken from the table for natural gas) is adjusted by a factor K.

$$Q_{kor} = \frac{Q}{K}$$

$$K = \sqrt{\frac{0.78}{SG}}$$

SG = specific gravity of the flowing gas under atmospheric conditions.

INSTALLATION

The diagram alongside shows an installation example of an Instromet security shut-off valve IPS-L complete with external control line and bypasses. In this configuration the IPS-L model protects the outlet pressure of the regulator against overpressure.

The types 1" to 3" can be assembled in any position in both horizontal and vertical lines.

BYPASS

In the event that the shut-off valve has closed, the upstream and downstream pressure must first be

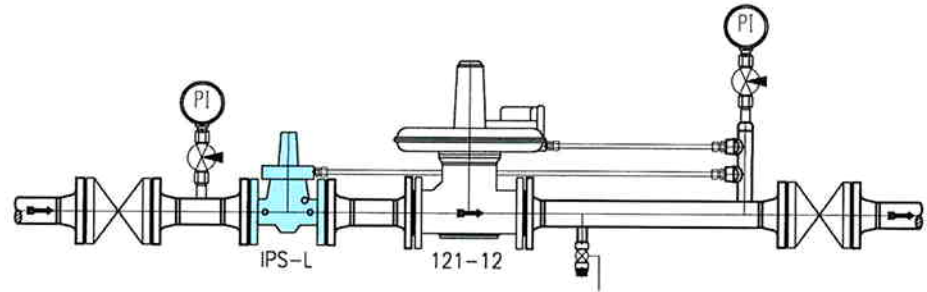

equalized before opening the valve manually. By installing a bypass with push button valve between the inlet and outlet side of the shut-off valve, by opening the push button valve, the upstream and downstream pressure can be equalized. The valve can be opened by means of the resetting shaft using a standard spanner or key which is supplied

with each security valve. In the case of small pressure differences, a bypass is not necessary (max. 0.5 bar). 2" and 3" connections are fitted standard with connecting points (1/4" NPT) and at extra charge can be provided with a bypass. 1" connections can be fitted with connection points on special request.

MATERIALS SPECIFICATION

Valve Body*	Ductile	Cast Steel
Upper Diaphragm Case 1" Screwed and 2" - 3" flanged Low Pressure Models-L High Pressure Models-H	Aluminum / CI Ductile	Aluminum / CI Ductile
Chamber Adaptor 3" flanged Model	Steel	Steel
Control Chamber External Control Models A Screwed- Low Pressure-L Screwed-High-pressure-H B 2" - 3" Flanged-Low Pressure-L 2" - 3" Flanged-High Pressure-H	Aluminum / CI Ductile Aluminum / CI Ductile	Not available Ductile Not available Ductile
Valve disc** A 1" Screwed B 2" - 3" Flanged	Aluminum / CI Aluminum / CI	Aluminum / CI Aluminum / CI
Diaphragm	Buna-N with nylon re-enforcement	Buna-N with nylon re-enforcement
Orifice	Brass	Brass
Disc Arm A 1" Screwed B 2" - 3" Flanged	Steel Steel	Steel Steel
Latch Lever A 1" Screwed B 2" - 3" Flanged	Steel Steel	Steel Steel
Resetting Shaft	Steel	18-8 SS Steel
O-Rings***	Buna-N	Buna-N

* The valve bodies of the 1" screwed models are only available in cast steel.

** The poly-U red on the valve discs has a strength of 70 -80° shore or higher, when depends on the pressure.

*** On request available in viton.

**INSTROMET
SECURITY
SHUT-OFF
VALVES
ARE NOT
SUITABLE FOR
OXYGEN DUTY.**

HOW TO ORDER

In order to supply the best security shut-off valve for your application, please provide the following information:

1. Type of shut-off valve
2. Dimensions and connections
3. Working pressure and temperature
4. Shut-off pressure required
5. Flow rate
6. Liquid or gas
7. Flow direction (left-right is standard)
8. Options required