

Technical Specifications

Libra 350 i Smart Gas Meters

Parameter	Characteristics
Applicable Metering Standards	BS EN 1359, EN14236
Maximum Operating Pressure	100 mbar
Maximum Flow Rate (Qmax)	6.00m ³ / Hr
Maximum Flow Rate (Qmin)	0.04m ³ / Hr
Pressure drop (max)	<2mB
Accuracy	Class 1.5 (0.04m ³ – 6m ³ /Hr)
Gas Type	Second Family gases
Case Construction	Deep drawn coated steel
Gas Connections	1" BSP to BS746 ¾" to ISO228-1 Class B ¾" to NEN 3084 1¼" to ISO228-1 Class B DN25 to DIN3376-2
Measurement Technology	Time of Flight
Shut off Valve	Internal electrically operated
Display	2 line by 16 character dot matrix with backlight
Battery Type	Lithium thionyl chloride 3.6v 'D' cell
Shock and Vibration (transit)	BS EN 1359:1999
Operation Temperature	-10°C to 40°C
Water Resistance	IP54
Humidity	95% non condensing
ESD	BS EN 61000-4-2 Level 3
RF Susceptibility	BS EN 61000-4-2 Level 3
RF Emissions	BS EN 61000-6-3
Metrology Approvals	MID
Weight	≈ 2.7 Kg
Battery Life	>10 years normal operation

Dimensions (mm)

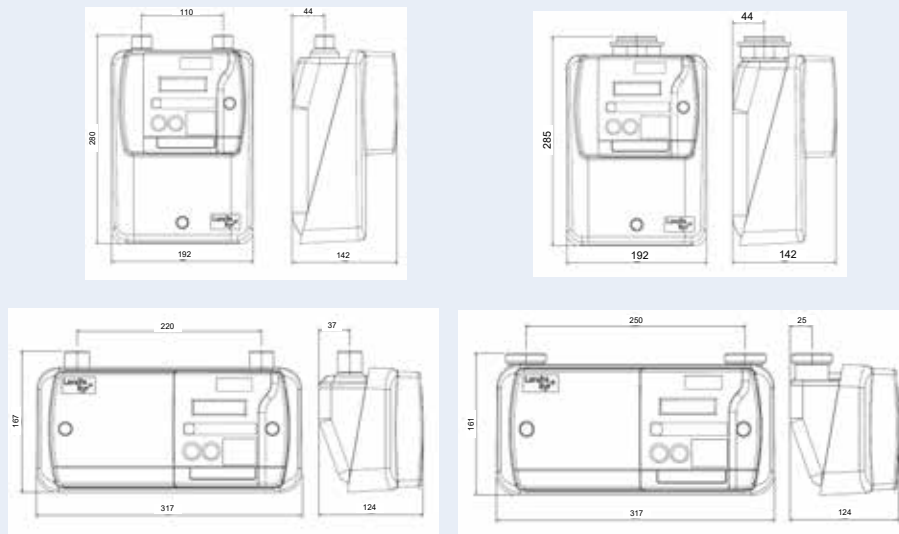

Landis+Gyr Libra350i Gas Meters



Benefits

Libra 350 i Gas Meter

Remote Communication and Configuration

+ The Libra 350 i provides 2 variants of communications module, wired and wireless M Bus, which provides Smart Metering functionality to the Landis+Gyr E6V Electronic Domestic Gas Meter.

+ Used as part of the Landis+Gyr dual fuel solution the module provides the consumer with consumption information on current and historic usage values and associated costs via the ecoMeter Home Energy Monitor.

+ Data is transferred from the module to the Landis+Gyr 5236 electricity meter via Low Power Radio or Wired M Bus communication, sending the latest gas consumption readings to the electricity meter at hourly intervals. The 5236 electricity meter then passes the data to the ecoMeter Home Energy Monitor using (LPR) communications.

+ The data sent from the gas module to the electricity meter can also be sent back to the utility software via the P3 GPRS Port.

+ The consumer can view the consumption and cost information associated with the gas usage via the ecoMeter displays.

+ The electricity meter will return the data to the back office either by a scheduled read or ad-hoc request for consumption data.

+ The two way communication medium between the back office and the electricity meter enables configuration for the gas meter can be sent remotely from the back office via the SMS messaging facility. Once the configuration details have been received by the electricity meter, the details are then sent to the gas meter via LPR when the next half hour communication window is attained.

Key Features

Libra 350 i Gas Meter

Remote Valve Operation

The remote functionality of the gas module and back office system enables the operation of remote disconnect or enabling of the gas meter valve, user intervention is required to open the valve. The valve can be opened or closed by performing a simple operational command using the back office software, the command is sent via SMS to the 5236 electricity meter which in turn sends the command to the gas meter via the M Bus link (wired or wireless).

Remote Meter Reading

Gas usage data can be sent to the back office system using M Bus commands. The user can define a scheduled period where the values can be returned to the system, or an ad-hoc request can be performed to return the latest data readings. The meter readings can also be used to record hourly profiling.

Tamper Alerts

In event of a tamper being detected at the gas meter communication with the 5236 electricity meter allows alerts to be sent to the back office system to indicate when a tamper has been detected at the gas meter.

Temperature Compensation

The gas meter is fitted with a temperature measuring device and maintains both an unconverted and a temperature converted register.

Installation

The installation process and association with the electricity meter follow the standard M Bus discovery process. Other installation functions are available in a service menu controlled by PIN entry. The wireless gas meter is bound to the M Bus to M Bus wireless convertor via the service menu. The installation can be prepared using the purge function to enable priming of the network.

Service Functions

The Libra 350 i has all necessary service functions included in the product in an engineering menu that is protected by a pin code.



The Libra 350 i Gas Module works in conjunction with the Landis+Gyr 5236 electricity meter and ecoMeter Home Energy Monitor via Low Power Radio communications providing the complete Dual Fuel system

