



Note: In the following text, the term meter refers to both the cold-water meter and the hot water meter.

1. General information



The meter left the factory in a faultless condition where safety and hygiene are concerned.



Calibration relevant security seals on the meter must not be damaged or removed. Otherwise, the guarantee and calibration validity of the meter will lapse.



Further technical support will be provided by the manufacturer on request.

2. Safety information



The meter may only be used in building service engineering systems and only for the applications described.



The local regulations (installation etc.) must be adhered to.



Adhere to the operating conditions according to the dial plate during use. Non-adherence can cause hazards and the guarantee will lapse.



In no case do any welding, drilling, or soldering near the meter.



Do not lift the meter by the electronic unit.



Protect the meter against damage from shocks or vibrations at the mounting place.



Only personnel trained in the installation and operation of meters in building service engineering systems, may install or remove the meter.



The meter is suitable for drinking water. Take necessary hygiene measures during installation:

Only remove the meter from its individual packaging at the mounting place.

Wear disposable gloves.

Clean and sanitize the relevant tools before installing the meter.

Protect the measuring tube and thread surfaces from dirt and contact.



Be aware of sharp edges on the thread, flange and measuring tube.



After installing the meter, check the leak-tightness of the system.



As far as disposal is concerned, the meter is a waste electronic appliance in the sense of European Directive 2012/19/EU (WEEE) and it must not be disposed of as domestic waste. The relevant national, legal regulations must be observed as the appliance must be disposed of via the channels provided for this purpose. The local and currently valid legislation must be observed.



You can return the lithium batteries to the manufacturer for appropriate disposal following use. When shipping please observe legal regulations, in particular, those governing the labelling and packaging of hazardous goods.



Do not open the batteries. Do not bring batteries into contact with water or expose them to temperatures above 80 °C.



The meter does not have any lightning protection. Ensure lightning protection via in-house installation.

3. Scope of delivery

Water meter
Operating and Installation Instructions
2 flat seals
Optional backflow preventer

4. Additional elements

Sealing clamp DN15
Sealing clamp DN20
Backflow preventer DN15
Backflow preventer DN20
Flat seal DN15
Flat seal DN 20
Meter bolting DN 15 lead-free
Meter bolting DN 20 lead-free

5. Installation conditions

Installation conditions

Pressure class	MAP 16 (up to 16 bar)
Installation position	Optional, horizontal, or vertical
Inlet and outlet section	U0D0 (not necessary)
Water temperature	0.1...50 °C
Cold water meter	
T50	
Water temperature	30...70 °C
Hot water meter	
T30/70	

Environmental conditions

Environmental class	O (OIML R49) for outdoor installation
Mechanical class	M2 (MID)
Electromagnetic class	E1 (MID)
Protection class	IP68
Max. height	2000 m above NN
Operating temperature	-10 ... 65 °C (with flow)
Storage temperature	-20 ... +70 °C
UV protection	Stabilized

6. Installation

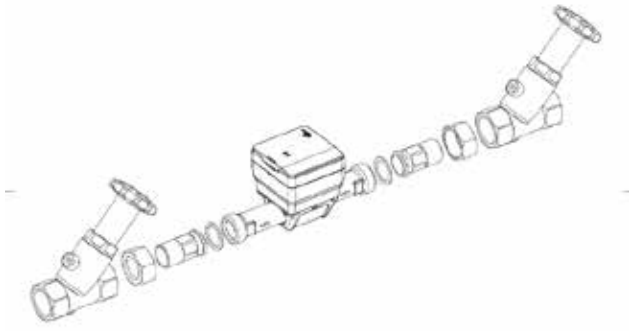

Fig. 1: Example Installation

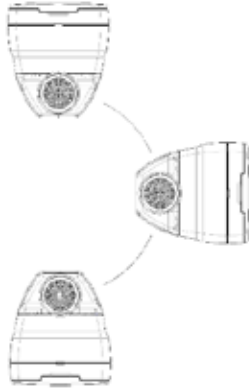

Fig. 2 Recommended installation position



Note: During installation, adhere to the notes from chapter 1 and 2.



Note: Observe the dimensions of the meter and check whether there is sufficient space available.



Note: The meter must not be exposed to stress or forces caused by pipes or fittings. If this cannot be guaranteed permanently, improve the installation site or fix the pipes, e.g. with suitable connection brackets.

To install the meter, proceed as follows:

1. Close all valves before and after the mounting place.
2. If necessary, remove the old meter. Collect the excess water in a suitable container.
3. Remove the old sealings and residues of teflon tape and hemp.
4. Clean the union nuts thread and the sealing surfaces at the screw connections.
5. Install the provided sealing at the threaded connector of the meter. Check if the sealing is properly positioned and is free of damage.
6. When using a backflow preventer, check its correct placement at the meter (see chapter 7).
7. Fit the meter horizontally or vertically so that the arrow on the housing and the flow direction match.
8. Tighten the screw connections. Note and use the tightening torques specified in the following table and the corresponding angle from contact of the union nut with the gasket:

Flat gasket	Novapress basic	
Meter thread	¾"	1"
Tightening torque	10 – 15 Nm	25 – 30 Nm
Angle from contact	45 – 60°	45 – 60°

9. Pay attention to the correct placement of the union nut.
10. Ensure that all connectors are tightened securely, and the meter is properly installed.
11. Open all valves before and after mounting place and vent the installation.

12. Check the installation for leakage.
13. Seal the screw connection to protect it against manipulation (see chapter 8).

7. Backflow preventer

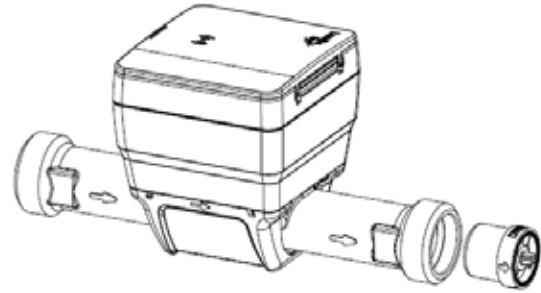

Fig. 3: Installation backflow preventer (available as accessory)

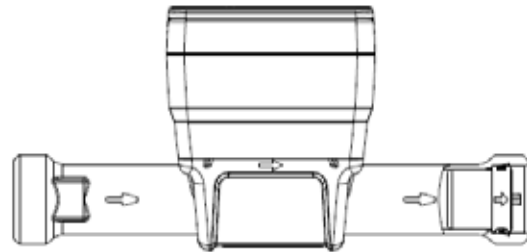

Fig. 4: Example backflow preventer when installed.

8. Sealing

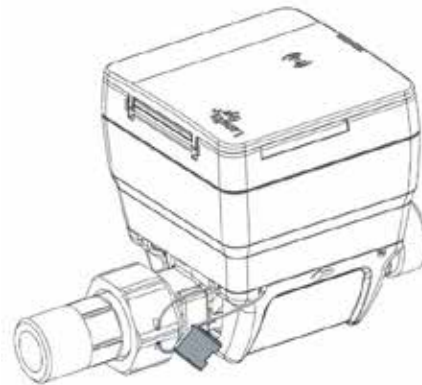

Fig. 5: Example sealing with wire seal

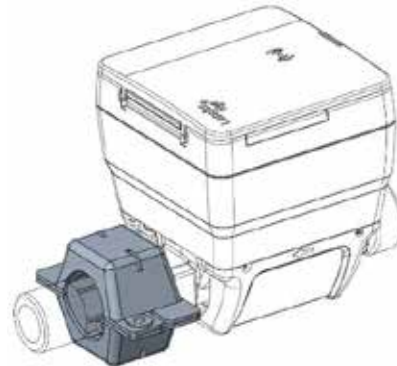
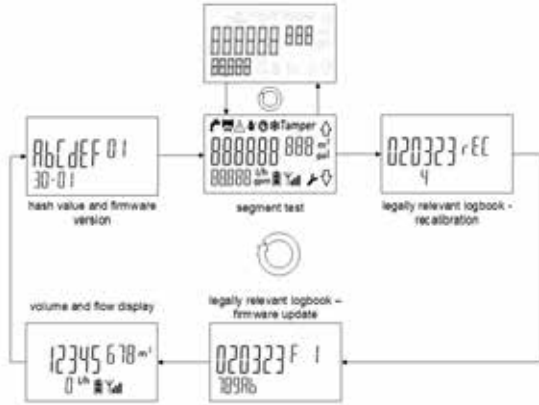

Fig. 6: Example sealing with sealing clamp (available as additional element)

9. Interface and Communication

The meter is equipped with an NFC interface according to ISO/IEC 14443 standard.



10. Parameterization via UltraConnect

The meter can be read out and parameterized via the UltraConnect App. Further information can be found in the meter's Technical Description.

11. Automatic Commissioning

Note: The meter can be activated manually via the UltraConnect app. Further information can be provided on request.





The meter automatically starts measuring and communication when the measuring tube is filled with water. The display SLEEP changes to a regular display.

With  the display indicates the correct flow direction, and the flow display shows the current flow rate.

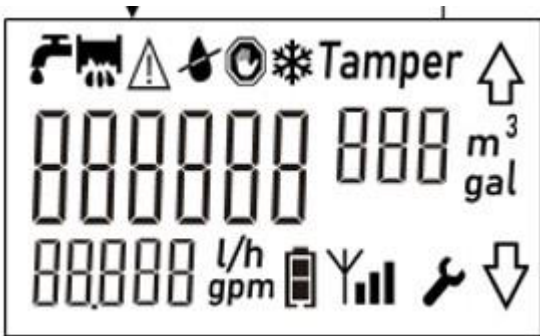
12. Display

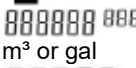
Note: To prevent reading errors, the decimal places of the values displayed are superscripted.

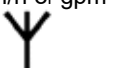











Icon	Explanation
	Forward flow
	Current volume
	Unit for volume
	Current flow
	Unit for flow
	Server connection established



Signal quality with LoRa or NB-IoT

13. Error messages

The meter continuously runs a self-diagnosis and can thus recognize and display various error messages.

Error icon	Error	Cause / Solution	Reset error via Ultra-Connect
	Leakage	Cause: Permanent flow. Solution: Check the installation for leakage.	X
	Pipe burst	Cause: Permanent high flow. Solution: Check the installation for pipe burst.	X
	Internal error	Cause: Meter failure. Solution: Contact the Service.	-
	Meter dry	Cause: No water can be detected in the pipe. Solution: Vent the installation.	-
	Manipulation	Cause: An access without the correct certificate was detected. Solution: Check the meter for manipulation.	X
	Stagnation	Cause: No flow can be measured. Solution: Rinse the installation.	-
	Frost / Ice	Cause: Water temperature is too low. Solution: Protect the meter from frost or ice.	X
	Reverse flow	Cause: Backflow against installation direction. Solution: Check the installation direction.	-
	Battery status	Cause: Battery status for >540 days remaining. Solution: Plan to replace the meter.	-
	Critical battery	Cause: Battery status for <180 days remaining. Solution: Replace the meter.	-
	Calibration mode active	Cause: Calibration seal broken. Solution: Contact the Service.	-

14. Technical Data



Note: The information on the meter must be observed!

Metrology

Measuring accuracy	Class 2 (OIML R49)
Measuring range	R250 (optional: R400, R160)
Temperature class	T50 (cold water), T30/70 (warm water)
Measure interval	1 Hz

Installation

Pressure class	MAP 16 (bis 16 bar)
Installation position	Optional, horizontal, or vertical
Filter	Standard
Backflow preventer	Optional

Environmental Conditions

Environmental class	O (OIML R49) for outdoor installation
Mechanical class	M2 (MID)
Electromagnetic class	W270 E1 (MID); W370 E2 (MID)
Safety class	IP68
Max. height	2000 m above NN
Ambient temperature	-10 ... 65 °C (with running water)
Storage temperature	-20 ... +70 °C
UV protection	Stabilized

Power supply

Power supply type	Battery for 15 years (+2 years storage time)
Battery type	D-cell Lithium
Lithium content	5 g per battery
Number of batteries	1

Communication

Available Communication type	LoRa @/wM-Bus or NB-IoT
App Support	Yes (Service Software App, Info Finder App)



CONTROLS SUPPLY CHAIN

VALVES ACTUATORS INSTRUMENTATIONS