

Gas Pressure Regulator RMG 214 (D 144a)



**Operation and Maintenance,
Spare Parts**

214.20
edition 07/2003

Serving the Gas Industry - WORLDWIDE

1. General

The "Technical Description 214.00" for the gas pressure regulator of series RMG 214 contains technical data, versions and dimensions.

Our brochure "General Operating Instructions for Gas Pressure Regulators and Safety Devices" will be useful to fit the valve into the line, put into the line, put into service and find faults that might disturb the operation.

The construction, set-up, supervision and maintenance of gas pressure pressure stations are subject to various national technical rules, which should be strictly observed. In Germany please refer to the DVGW-Worksheets G 490, G 491 and G 495.

Note: The vent line of the integrated safety relief valve is to be connected to the open atmosphere (outside of the building).

The frequency of periodical maintenance of gas pressure regulator RMG 214 should be determined according to the prevailing conditions and the type and composition of the gaseous medium. We, therefore, abstain from imposing any fixed intervals. In Germany please refer to the recommendations given by the DVGW-Worksheets G 495.

For maintenance all parts are to be cleaned and subjected to a thorough visual inspection. A visual inspection should not be omitted when the course of operation or functional tests have shown lack of regulating accuracy.

Particular care should be given to the checking of sealings and diaphragms, as well as carrying and moving parts. Damaged parts should be replaced by new ones.

The item numbers referred to in the maintenance instructions are identical with those of spare parts drawings and spare parts lists. We recommend to keep all parts that are marked "W" in the spare parts lists in stock for prompt maintenance availability..

2. Special Operating Instructions

valve seat diameter

Take care that not more than the permissible inlet pressure prevails on the inlet side of the RMG 214 as to avoid damage to internal parts

| | |
|---------------------------|--------------------------------|
| valve seat diameter 6 mm | $p_{e \max} = 350 \text{ bar}$ |
| valve seat diameter 8 mm | $p_{e \max} = 220 \text{ bar}$ |
| valve seat diameter 11 mm | $p_{e \max} = 150 \text{ bar}$ |

regulating deviations

Admissible regulating deviations depend on constructive details and can be caused by:

- inlet pressure variations (see table in Technical Description 214.00 or in the RMG booklet)
- flow variations (accuracy depending on the individual setpoint spring, see table in Technical Description 214.00 or in the RMG booklet)
- flow resistance in the outlet channels (increases with higher flowrate)

bubble-tight shut-off

As the regulators have valve sealing made of plastic material, the close bubble-tight at zero consumption.

3. Maintenance Hints

3.1 piston (7)

The piston (7) responsible for tight shut-off can be exchanged after removing the screw cap (21).

3.2 internal parts (valve seat (8), guide piece (10), diaphragm (11), setpoint spring (14), etc.)

The internal parts can be reached from under the body by unscrewing the spring housing (15) or the intermediate piece (52).

The internal parts should move easily and must be faultless. Take care that the measuring diaphragm is not beginning to dissolve or fall apart due to aggressive gas components.

NOTE: When mounting the spring housing take care not to tighten the lid too strongly. Only apply enough force to press the diaphragm down for not more than 1 mm. This is sufficient to achieve tightness.

4. Spare Parts RMG 214
4.1 Spare Parts Drawing
4.1.1 Version with internal measuring impulse connection

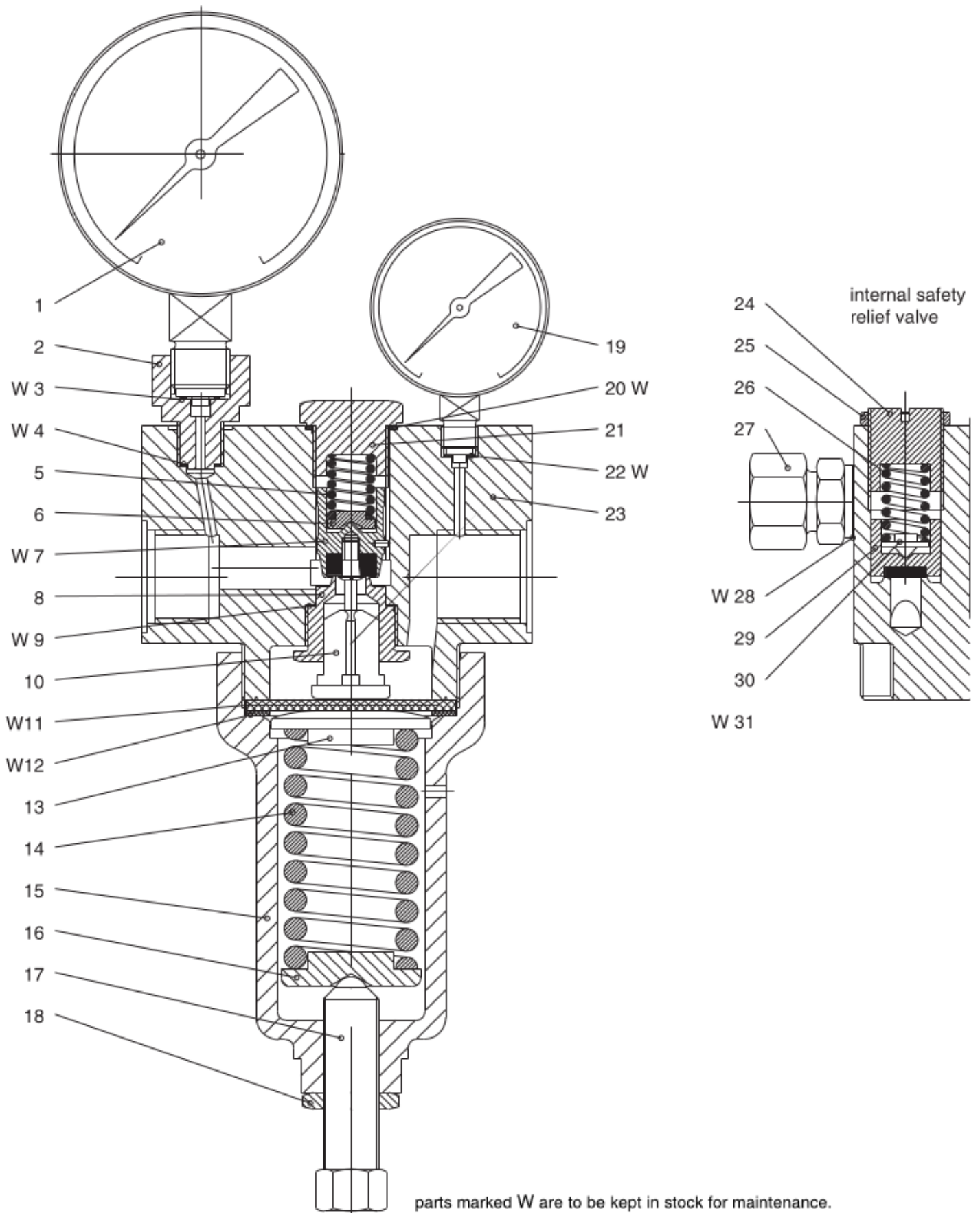

4. spare parts RMG 214
4.1 spare parts drawing
4.1.2 version with external measuring line

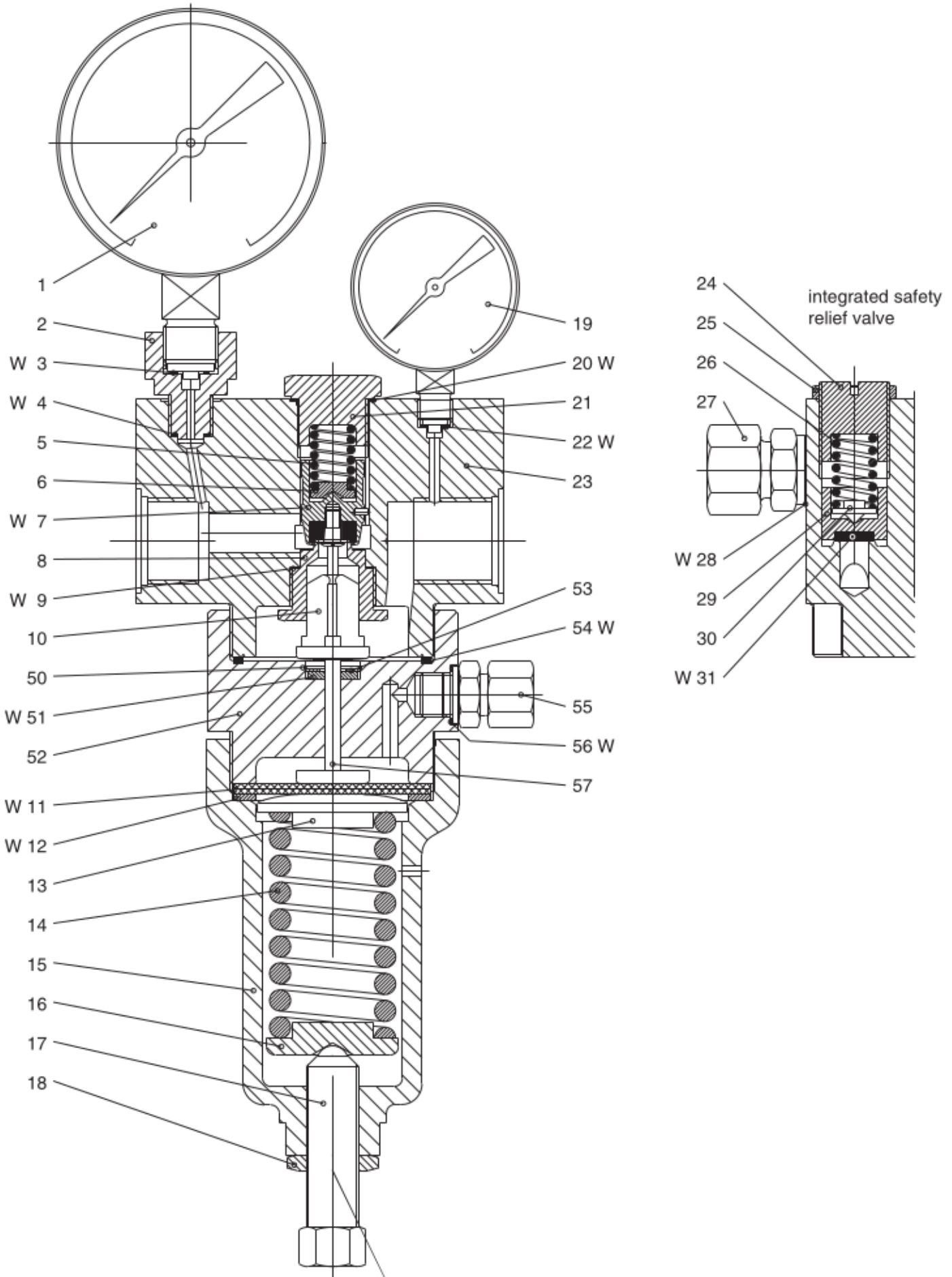

- 4. spare parts RMG 214
- 4.1 spare parts drawing
- 4.1.3 back-flow proof version, only for valve seat dia. 6 mm

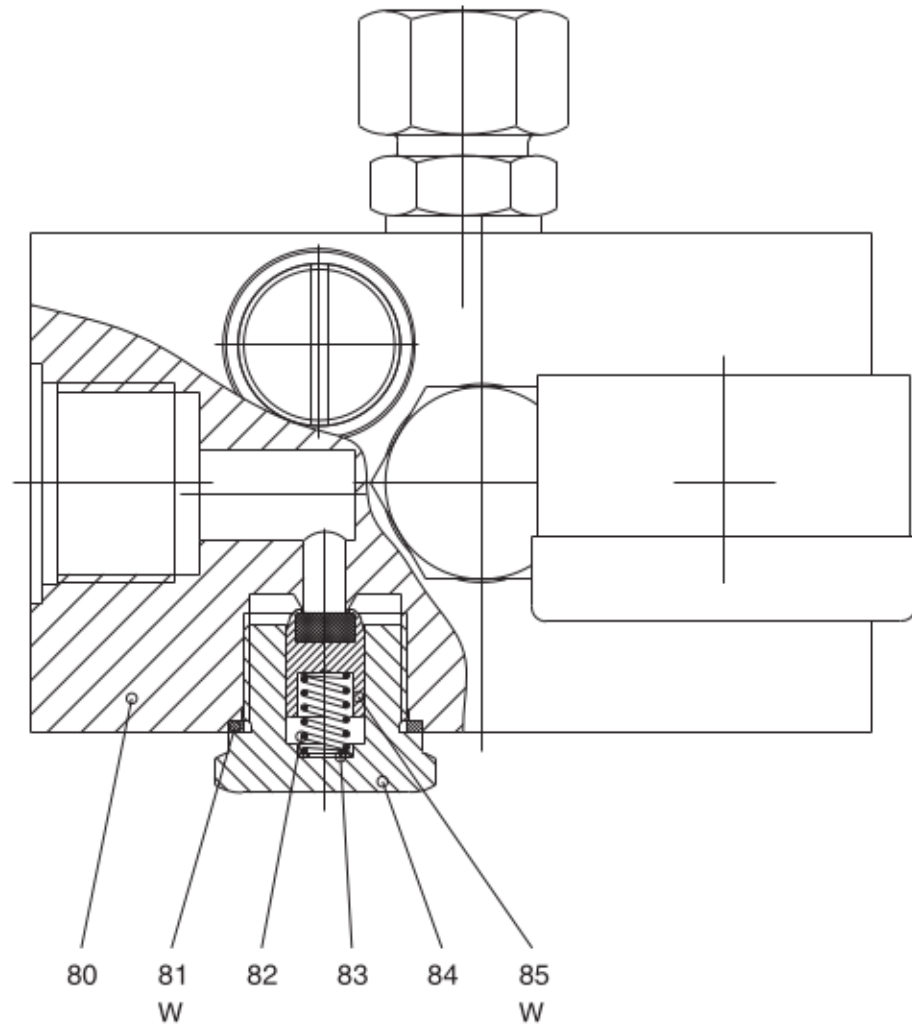

parts marked W are to be kept in stock for maintenance.

4.2 spare parts list RMG 214

| pos.-no. | description | amount | W | material | RMG part no. |
|----------|--|--------|---|------------|--------------|
| 1 | gauge, at option: 0 to 400 bar | 1 | | Ms | 00 026 772 |
| | 0 to 100 bar | 1 | | Ms | 00 026 479 |
| 2 | intermediate piece | 1 | | St | 10 015 185 |
| 3 | sealing ring at option: 0,5 mm thick | 1 | W | LM | 00 018 788 |
| | 1,0 mm thick | 1 | W | LM | 00 018 323 |
| 4 | sealing ring | 1 | W | Cu | 00 018 586 |
| 5 | setpoint spring | 1 | | NFSt | 10 014 771 |
| 6 | intermediate piece for spring | 1 | | Ms | 10 014 785 |
| 7 | piston, at option: for valve seat dia. Ø 6 and Ø 8 p _e up to 100 bar | 1 | W | NSt/Teflon | 10 014 764 |
| | p _e above 100 bar for valve seat dia. Ø 11 p _e up to 100 bar | 1 | W | NSt/Nylon | 10 014 768 |
| | p _e above 100 bar | 1 | W | NSt/Teflon | 10 014 775 |
| | | 1 | W | NSt/Nylon | 10 014 778 |
| 8 | valve seat dia., at option: valve seat dia. Ø 6 | 1 | | Ms | 10 014 761 |
| | valve seat dia. Ø 8 | 1 | | Ms | 10 014 772 |
| | valve seat dia. Ø 11 | 1 | | Ms | 10 014 737 |
| 9 | sealing ring | 1 | W | Cu | 00 003 879 |
| 10 | guide piece | 1 | | Ms | 10 014 740 |
| 11 | diaphragm, at option: p _a to 10 bar (4 mm thick) | 1 | W | KG | 10 014 757 |
| | p _a to 10 bar (6 mm thick) | 1 | W | KG | 10 014 759 |
| 12 | sealing ring, at option: p _a to 10 bar (for diaphragm 4 mm thick) | 1 | W | K | 00 018 167 |
| | p _a to 10 bar (for diaphragm 6 mm thick) | 1 | W | K | 00 018 056 |
| 13 | spring plate, at option: p _a 1 to 5 bar for spring F1 Ø 8 | 1 | | St | 10 014 746 |
| | p _a 3 to 25 bar for spring F2 Ø 11 | 1 | | St | 10 014 749 |
| | p _a 5 to 60 bar for spring F3 Ø 14 | 1 | | St | 10 014 752 |
| | p _a 10 to 80 bar for spring F4 Ø 16 | 1 | | St | 10 014 755 |
| 14 | spring, at option: p _a 1 to 5 bar F1 Ø 8 | 1 | | FSt | 10 014 745 |
| | p _a 3 to 25 bar F2 Ø 11 | 1 | | FSt | 10 014 748 |
| | p _a 5 to 60 bar F3 Ø 14 | 1 | | FSt | 10 014 751 |
| | p _a 10 to 80 bar F4 Ø 16 | 1 | | FSt | 10 014 754 |
| 15 | lid | 1 | | Ms | 10 014 736 |
| 16 | intermediate piece for spring, at option: p _a 1 to 5 bar for spring F1 Ø 8 | 1 | | St | 10 014 747 |
| | p _a 3 to 25 bar for spring F2 Ø 11 | 1 | | St | 10 014 750 |
| | p _a 5 to 60 bar for spring F3 Ø 14 | 1 | | St | 10 014 753 |
| | p _a 10 to 80 bar for spring F4 Ø 16 | 1 | | St | 10 014 756 |
| 17 | setpoint adjusting screw | 1 | | Ms/St | 10 014 738 |

parts marked W are to be kept in stock for maintenance.

material key:

| | | | | | |
|----|---------------|----|----------------------------------|------|-----------------------|
| St | ... steel | Cu | ... copper | FSt | ... spring steel |
| LM | ... aluminium | K | ... plastic material | NFSt | ... inox spring steel |
| Ms | ... brass | KG | ... rubber-like plastic material | NSt | ... inox steel |

| pos.-no. | description | amount | W | material | RMG part no. |
|----------|-----------------------------|--------|---|----------|--------------|
| 18 | hexagonal nut | 1 | | Ms | 18 353 938 |
| 19 | gauge or Verschlufschraube | | | | |
| | gauge, at option: | | | | |
| | 0 to 10 bar | 1 | | Ms | 00 026 281 |
| | 0 to 25 bar | 1 | | Ms | 00 026 284 |
| | 0 to 60 bar | 1 | | Ms | 00 026 283 |
| | 0 to 100 bar | 1 | | Ms | 00 026 285 |
| | sealing screw | 1 | | Ms | 10 014 784 |
| 20 | sealing ring | 1 | W | Cu | 00 018 512 |
| 21 | sealing screw | 1 | | Ms | 10 014 787 |
| 22 | sealing ring, at option: | | | | |
| | 0,5 mm thick | 1 | W | LM | 00 018 797 |
| | 1 mm thick | 1 | W | LM | 00 018 818 |
| 23 | body G1 | 1 | | Ms | 10 014 783 |
| 24 | adjusting screw | 1 | | Ms | 10 014 791 |
| 25 | counter nut | 1 | | Ms | 10 014 797 |
| 26 | spring, at option: | | | | |
| | p _a up to 30 bar | 1 | | NFSt | 10 014 771 |
| | p _a above 30 bar | 1 | | NFSt | 10 014 794 |
| 27 | screw connection DS 10 | 1 | | St | 00 030 015 |
| 28 | sealing ring | 1 | W | LM | 00 018 524 |
| 29 | piston | 1 | | Ms | 10 014 789 |
| 30 | egalizing piece for spring | 1 | | Ms | 10 014 795 |
| 31 | sealing hub | 1 | W | KG | 00 018 057 |
| 50 | wire ring | 1 | | NSt | 10 015 198 |
| 51 | sealing washer | 1 | W | Teflon | 10 015 197 |
| 52 | intermediate piece | 1 | | Ms | 10 015 195 |
| 53 | glide washer | 1 | | Ms | 10 015 191 |
| 54 | sealing ring, at option: | | | | |
| | 2,0 mm thick | 1 | W | LM | 00 018 639 |
| | 2,5 mm thick | 1 | W | LM | 00 018 640 |
| | 3,0 mm thick | 1 | W | LM | 00 018 641 |
| 55 | screw connection DS 16 | 1 | | St | 00 030 008 |
| 56 | sealing ring | 1 | W | LM | 00 006 608 |
| 57 | steering pin, complete | 1 | | Ms | 10 015 208 |
| 80 | body G1 | 1 | | Ms | 10 015 201 |
| 81 | sealing ring | 1 | W | LM | 00 018 706 |
| 82 | spring | 1 | | NFSt | 10 015 206 |
| 83 | sealing ring | 1 | | Cu | 00 005 121 |
| 84 | screw connection | 1 | | NSt | 10 015 203 |
| 85 | piston | 1 | W | NSt/K | 10 015 204 |

parts marked W are to be kept in stock for maintenance.

material key:

| | | | | | |
|----|---------------|----|----------------------------------|------|-----------------------|
| St | ... steel | Cu | ... copper | FSt | ... spring steel |
| LM | ... aluminium | K | ... plastic material | NFSt | ... inox spring steel |
| Ms | ... brass | KG | ... rubber-like plastic material | NSt | ... inox steel |