

Non-Hazardous Areas Adjustable Pressure Switch

605D* - Diaphragm Sensor



DESCRIPTION

- Highly reliable devices utilizing the CCS Dual-Snap® Belleville disc spring principle pioneered by CCS' engineers.
 - Engineering based on aerospace technology.
 - Rigid, midsize and internally adjustable for convenient field set point adjustment.
 - Repeatable and stable set points.
 - Vibration and shock resistant.
 - High cycle life.
 - High over-pressure capability. (System and Proof)
- High - low over high capability.
 - Various options for wetted materials and electrical ratings to meet a wide range of application requirements and media compatibility.

SHIPPING WEIGHT: APPROXIMATELY 40 OUNCES (1134 GRAMS)

SERIES:

605D*

ADJUSTABLE SET POINT RANGE: DIFFERENTIAL PRESSURE:

0.4 to 75 PSID
 0.02 to 5.17 bar
 2.07 to 517 kPa

OPERATING TEMPERATURE:

Temperature limits change with o-ring selection.

-40° to 186°F
 -40° to 86°C

STANDARD FEATURES:

- CE Mark
- CRN
- CCC
- NEMA: 4, 13, 4X / IP66
- Weatherproof
- Internal Case Ground

INSTALLATION DRAWING

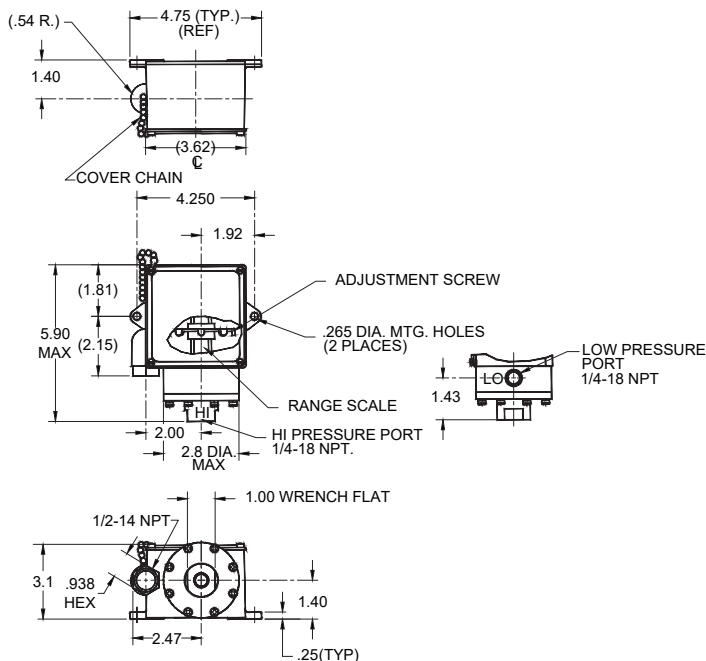

DESIGN PRINCIPLES

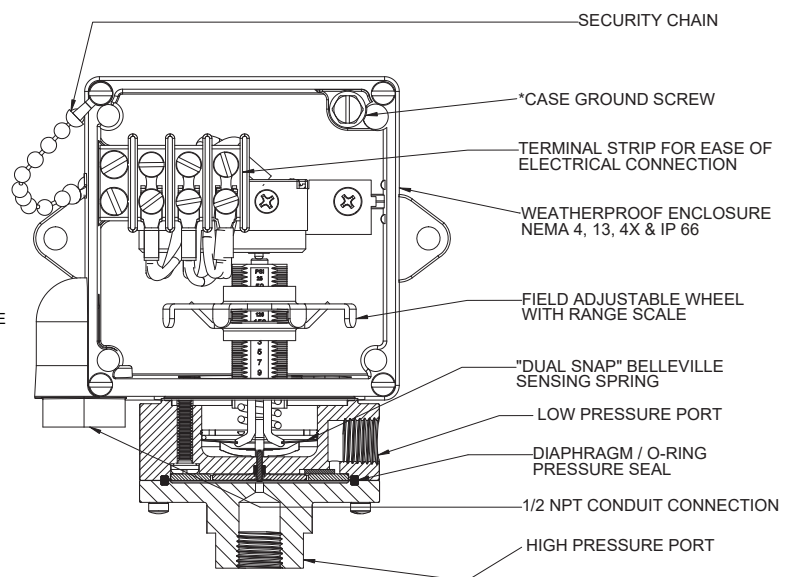

SERIES 605D

Non-Hazardous Areas Adjustable Pressure Switch

605D* - Diaphragm Sensor

OPERATING AND ORDERING DATA

SERIES 605D*	WETTED PARTS: 1/4"-18 NPT ALUMINUM PRESSURE PORT, POLYIMIDE DIAPHRAGM, VITON O-RING						
	ADJUSTABLE SET POINT RANGE			APPROX. DEAD BAND PSI (BAR)	MAX SYSTEM PRESSURE PSIG (BAR)	PROOF PRESSURE PSIG (BAR)	
	INCREASING PRESSURE PSID (BAR)	DECREASING PRESSURE PSID (BAR)	BOTH PORTS SIMULT.			HIGH OVER LOW LOW OVER HIGH	
						HIGH	LOW
605D*1	1-18 (0.069-1.24)	.4-17.4 (0.02-1.19)	.6 (0.042)	400 (28)	750 (52)	750 (52)	400 (28)
605D*2	6-75 (0.42-5.17)	2-71 (0.14-4.9)	4 (0.28)				
605DM*1	1.4-18 (0.097-1.24)	0.5-17.1 (0.034-1.18)	.9 (0.062)				
605DM*2	6-75 (0.42-5.17)	2-71 (0.14-4.9)	4 (0.28)				
SERIES 605DZ*-7011	WETTED PARTS: 1/4"-18 NPT 300 STAINLESS STEEL PRESSURE PORT, STAINLESS STEEL DIAPHRAGM, VITON O-RING						
	ADJUSTABLE SET POINT RANGE			APPROX. DEAD BAND PSI (BAR)	MAX SYSTEM PRESSURE PSIG (BAR)	PROOF PRESSURE PSIG (BAR)	
	INCREASING PRESSURE PSID (BAR)	DECREASING PRESSURE PSID (BAR)	BOTH PORTS SIMULT.			HIGH OVER LOW LOW OVER HIGH	
						HIGH	LOW
605DZ*1-7011	2-18 (0.138-1.24)	.6-16.6 (0.041-1.14)	1.4 (0.096)	400 (28)	750 (52)	400 (28)	100 (6.9)
605DZ*2-7011	9-75 (0.62-5.2)	3-69 (0.21-4.76)	6 (0.414)				

HOW TO ORDER

Follow these steps to build your part number:

1. Specify the series based on your required set point, range, dead band, system pressure and proof pressure.
2. Add desired options model code letter.
3. Add the applicable standard suffix number.

(Ex: 605DM2-7008)

PRESSURE CONVERSION

1 BAR = 14.5 PSI
1 kPa = 0.145 PSI

OPTIONS MODEL CODES

- C:** See 605DC catalog page
F: Ethylene Propylene O-Ring
M: DPDT Electrical
X: Double Break Switching Element

OPTIONAL STANDARD MODIFIED SUFFIXES

7008: Gold Contacts

Note: Additional modified standard suffixes are available, consult CCS sales department or CCS Representative.

ELECTRICAL CHARACTERISTICS RATING OF SWITCH ELEMENT

VOLTS	AMPERES		
	SPDT	DPDT "M"	Dbl Brk "X"
	Res.	Res.	Res.
125 AC - 50/60 Hz	15	5	15
250 AC - 50/60 Hz	15	5	15
480 AC - 50/60 Hz	15	-	15
28 DC	6	5	-
125 DC	.5	.5	1
250 DC	.2	-	.5
*125 AC - 50/60 Hz	1 max	1 max	-
*30 DC	1 max	1 max	-

*Gold Contacts -7008 Suffix

SCHEMATIC AND WIRING CODE

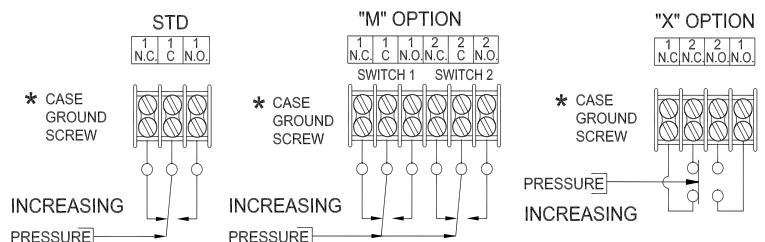

CERTIFICATIONS

Consult CCS website for complete certification and approval listing.