

C210

Series Control Valves

High Pressure Control valves

technical specifications

| General | |
|-----------------------------|---|
| Type indication | C210 series |
| Pressure class | ANSI 300 and ANSI 600(*) |
| Inlet pressure range | 0 to 50 bar ANSI 300, 100 bar ANSI 600 |
| Outlet pressure range | 0-49,5 bar ANSI 300 0-100 bar ANSI 600 |
| Operating temperature range | -20°C to + 80°C(*) |
| Ambient temperature range | -30°C to + 80°C(*) |

(*) Other pressure classes up to ANSI 2500 and temperature ranges are available.

| Flow coefficient | | | |
|--------------------------|-----|-----------------------|-------------------------|
| Nominal size (inches/mm) | | Cg value | Cg value |
| | | HON C210 / HON C210-M | HON C210S / HON C210S-M |
| 1" | 25 | 400 | 370 |
| 2" | 50 | 2,000 | 1,210 |
| 3" | 80 | 4,000 | 2,800 |
| 4" | 100 | 6,760 | 4,970 |
| 6" | 150 | 14,400 | 10,100 |
| 8" | 200 | 27,100 | 19,700 |
| 10" | 250 | 37,000 | 30,000 |
| 12" | 300 | 48,000 | 38,500 |

Flow coefficient for hybrid trim upon request.

| Classification slam shut according to DIN 3380 / EN 334 | |
|---|-----------------------------|
| Accuracy class / | Pa ≤ 3 bar : RG 2.5 / SG 10 |
| lock-up pressure class | Pa > 3 bar : RG 1 / SG 2.5 |
| Lock-up pressure zone | SZ = 2.5 |
| DIN-DVGW registered & CE marked | |

Note: All pressures listed are overpressures.

| C210 dimensional data | | | | | |
|-----------------------|-----|-----|------|-----|------|
| Nominal size | | L | A | B | Mass |
| inches | mm | mm | mm | mm | kg |
| 2" | 50 | 292 | 715 | 85 | 80 |
| 3" | 75 | 356 | 820 | 105 | 110 |
| 4" | 100 | 432 | 835 | 140 | 160 |
| 6" | 150 | 559 | 1110 | 120 | 255 |
| 8" | 200 | 660 | 1200 | 210 | 365 |
| 10" | 250 | 787 | 1250 | 270 | 800 |
| 12" | 300 | 838 | 1285 | 320 | 1060 |
| 16" | 400 | 990 | 1815 | 405 | 1810 |

| Material specifications (standard) | | | |
|------------------------------------|-----------------------|-----------------|----------------------------|
| Part | Material | Part | Material |
| Valve body | A352-LCC(QT) or equal | Silencer | Metal foam stainless steel |
| Guide bushing | Steel chromium plated | Dynamic O-rings | Viton |
| | | Static O-rings | NBR |

Special materials upon request.

Capacity calculation

The following simplified formulas can be used to determine the capacity.

$$Q_n = \frac{13,57}{\sqrt{d(t_u + 273)}} \cdot C_g \cdot \sqrt{(P_u - P_d) \cdot (P_d + P_b)}$$

for $\frac{P_d + P_b}{P_u + P_b} \geq 0,5$

$$Q_n = \frac{0,5 \cdot 13,57}{\sqrt{d(t_u + 273)}} \cdot C_g \cdot (P_u + P_b)$$

for $\frac{P_d + P_b}{P_u + P_b} < 0,5$

For natural gas with $\rho_n = 0.83 \text{ kg/m}^3$,
 $d = 0.643$

For gasses other than natural gas

$$d = \frac{\rho_n \text{ gas}}{1.29}$$

- Q_n = capacity in Nm³/h
- P_u = upstream pressure in bar (g)
- P_d = downstream pressure in bar (g)
- P_b = atmospheric reference pressure (barometric)
- C_g = flow coefficient
- d = relative density (air=1)
- t_u = temperature of the gas at the inlet of the regulator in °C
- ρ_n = density of the gas at normal conditions (at T=273 Kelvin)

In case of a combination regulator and monitor, use the following serial thesis:

$$C_{g_tot} = \sqrt{\frac{1}{\left(\frac{1}{C_{g_Regulator}}\right)^2} + \left(\frac{1}{C_{g_Monitor}}\right)^2}$$

This C_{g_tot} can be filled in as C_g in one of the above mentioned formulas.

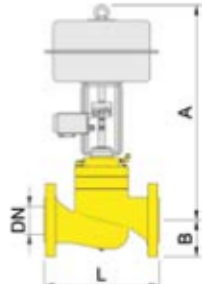

Dimensional sketch C210

general

C210(S), C210(S)-M, C210(S)-E

C210

The C210 series (former Gorter brand) consists of several effective high pressure control valves for use in gas transmission systems, gas distribution networks and industrial gas pressure or flow regulating systems.

The C210 has demonstrated its quality and usability since the late 1990's in regulating systems worldwide. Some of the world's largest regulating stations and power plants use C210 series control valves.

The valve is actuated by either pneumatic or electric power. Other means of actuation available upon request. The C210 series comprises 3 basic configurations:

- **C210(S)** : Standard model control valve with pneumatic actuator, with or without silencer (suffix 'S')
- **C210(S)M** : Monitor type control valve with pneumatic actuator, with or without silencer
- **C210(S)-E** : Control valve with electric actuator, with or without silencer

Pneumatic actuation

Available in either spring-to-open or spring-to-close, and with or without noise reducing cage (see features). Fitted with filter-reducer for instrument air treatment (max. 10 bar(g)), optional booster for increased valve travel speed, and optional solenoid for emergency override (i.e. valve assumes fail position, either open or closed, depending on installed actuator type). A piston type actuator is available for gas operated valves, for safe use of main line inlet pressure, eliminating the need of instrument air supply.

Electric actuation

Drives of several major suppliers are available to meet cost-effective solutions for all possible situations. Electric drives offer high accuracy and lockable position with a simple setup.

C210(S)-M

The C210(S)-M can be used as working or as a fully open monitor. A monitor is an emergency regulator that is activated immediately after the main regulator fails open. In contrast to other safety devices, such as safety shut-off or safety cut-off devices, the gas supply is not interrupted if the main regulator fails. The construction and operation of the C210(S)-M are similar to those of the standard C210 regulator. This gives the C210(S)-M its unique properties with respect to fast action, low lock-up pressure, accuracy and stability, making it superior to other fully open and working monitor designs. The monitor can be supplied with C210S-M or without low-noise cage C210-M.

Hybrid trim

The C210 control valves can be fitted with a hybrid low-noise cage. Using an in line silencer may result in a reduction of capacity. There are circumstances when the regulator must maintain a specific nominal capacity in combination with a low-noise level in case of both high and low inlet pressures. In those instances, a regulator with a greater nominal diameter normally would have to be selected

As an alternative to this, has successfully developed the hybrid low-noise cage. This hybrid low-noise cage guarantees noise reduction under normal operating conditions. In extreme situations where inlet pressure and gas speeds are low as is noise generation, the noise reduction potential can be optimised in combination with maximum capacity and minimum no-minal diameter. In this way, over dimensioning is avoidable.



C210-E



Pneumatic Positioner



features

> Low maintenance costs

- > Long maintenance interval because of:
 - minimal friction
 - minimal number of parts
- > Easy to assemble / disassemble:
 - regulator body remains in line during maintenance
 - seat ring is easy to inspect
 - entire trim removable (top entry)
- > The use of economical materials

> Optimal noise reduction

Using patented techniques and a noise-reducing cage, the C210S can reduce noise production to an acceptable minimum. Noise reduction up to 40 dB(A) is possible, depending on the user's environment.

> Optimal control at pressure differences from 0.5 bar

The C210 distinguishes itself from the competition by its ability to control the gas pressure perfectly at pressure differences from 0.5 bar. The optimally balanced valve construction of the C210 thus makes it highly suitable for extreme applications.

> Special patented valve seat

- > long maintenance interval due to the erosion-free enclosure of the seat ring
- > bubble-tight even at low temperatures
- > low lock-up pressure

> Excellent control characteristics

- > High degree of position control
- > High turn down ratio eliminates the need of any additional start-up streams
- > Fast response, because of:
 - large actuation capacity
 - minimal hysteresis
- > balanced trim design
- > Low seat force

> High specific flow rate

- > hydro dynamically favourable design of regulator body

> Remote or flow control

With the pneumatic positioner and position feedback the control valve can be used to accurately maintain a steady flow or pressure.

> Clear and complete technical documentation

- > satisfies current requirements
- > available in different languages

Because of its special construction, the low-noise cage has a noise reduction effect that is virtually independent of the flow rate. Moreover, noise reduction increases as the difference in pressure across the regulator increases.

Patented valve seat

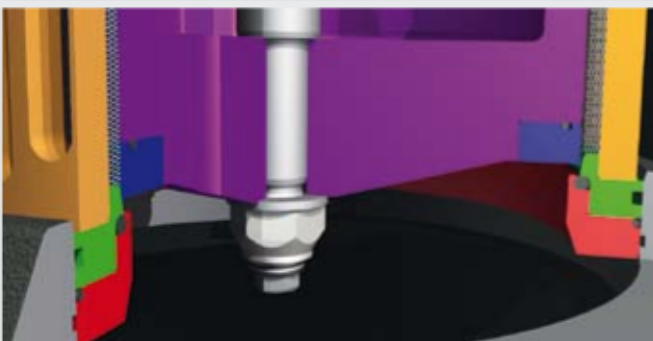

Low-noise cage



operation

Principle of operation

In normal operational condition, the monitor is fully open, and the active valve is regulating. Should the Active valve fail it will fully open on spring force, and the monitor will take over the regulation. Should the Monitor then fail also, it will close on spring force, interrupting the flow and pre-venting the downstream pipe from damage from overpressurising.

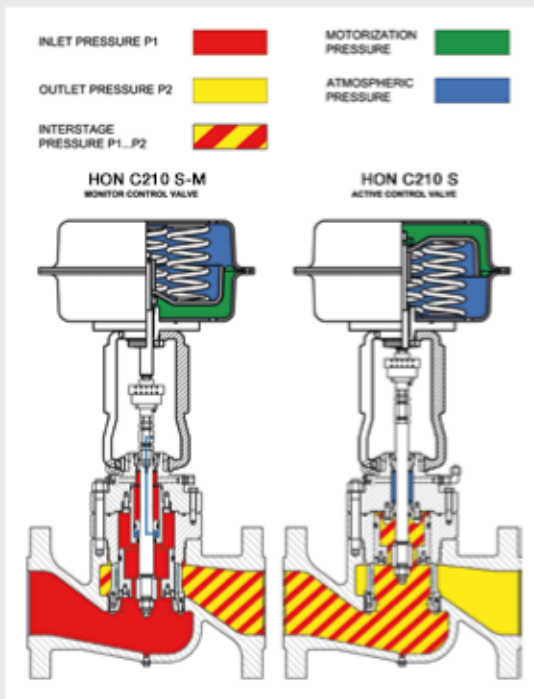

Operation scheme

