



# Rotary Meter Delta®

Commercial & Industrial Meter

Delta meters are volumetric meters. The flow of gas moves the pistons and each rotation traps and transfers a specific volume of gas. The movement is mechanically transmitted to the totaliser through the magnetic coupling.

## APPLICATIONS

Delta meters are designed to measure natural gas and various filtered, and non-corrosive gases. They are used when very accurate measurement is required, when the gas flow can be low or irregular.

Due to the volumetric principle of the Delta meter, its metrology is not influenced by installation conditions. Consequently, it can be used to build very compact stations without installing a straight pipe inlet before the meter.

Delta meters are approved for fiscal use.

## Technical Specifications

Flow rate	From 0.25 m <sup>3</sup> /h to 1000 m <sup>3</sup> /h, G10 to G650
Nominal Diameters	DN 25 to DN 150 (1" to 6")
Maximum Working Pressure	Up to 100 bar depending on the body material and flanging
Body Materials	Aluminium, ductile iron or steel. Compliant with the Pressure Equipment Directive 97/23/EC
Temperature Range	ATEX/PED: -30° C to +60° C MID: -25° C to +55° C Storage temperature: -40° C to +70° C
Metrology	In accordance with the EC and OIML, large rangeability up to 1:200, depending on the G-size Approvals EC (PTB): 1.33-3271.3-ROM-E11. Large rangeability (PTB): 1.33-3271.3-ROM-N05 Compliant with the Measuring Instrument Directive 04/22/EC
Intrinsic Safety Approval	L.C.I.E. 06 ATEX 6031 X - Compliant with the Directive 94/9/EC.

## Typical calibration curve

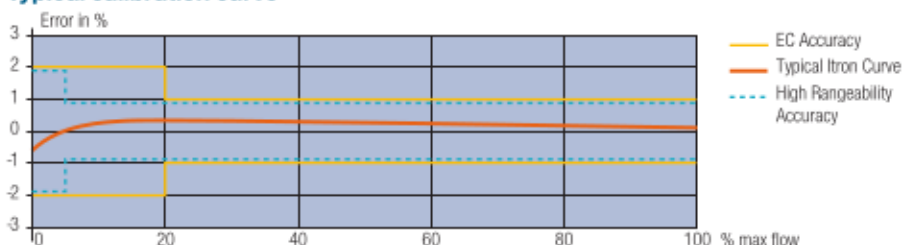

## KEY BENEFITS

- » Excellent metrological stability attested by customers over the years
- » No influence of installation conditions nor stop-and-go flow rate on the metrology
- » MID approved
- » Optimised pressure loss for low pressure network
- » Available in aluminium, ductile iron, or steel, for all applications
- » Equipped as standard with the Cyble target

## DESCRIPTION

A Delta meter is made of 5 main parts:

- » A measuring chamber that is limited by the body and the 2 base plates (1)
- » 2 pistons, which are synchronised by 2 gears and which rotate in opposite directions (2)
- » 2 lubricant covers (3)
- » A magnetic coupling to transmit the movement of the pistons to the totaliser (4)
- » A totaliser to register the measured gas (5)

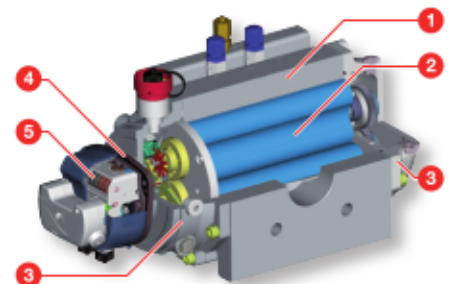

In accordance with the EC regulation, the maximum permissible error is +/-2% from Q<sub>min</sub> to 0.2 Q<sub>max</sub>, and +/-1% from 0.2 Q<sub>max</sub> to Q<sub>max</sub>. The WME (Weighted Measured Error) is less than 0.4%.

Typical Itron accuracy is +/-1% from Q<sub>min</sub> to 0.2 Q<sub>max</sub>, +/-0.5% from 0.2 Q<sub>max</sub> to Q<sub>max</sub>.



Delta DN80 G100 in aluminium equipped with the Cyble sensor

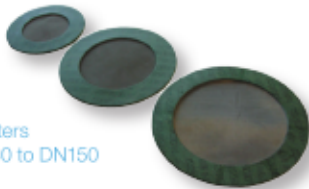

Gasket filters from DN40 to DN150



Delta DN80 G100 with Corus PTZ



Thermowell fitted with sealing holes



Mechanical drive according to EN 12480

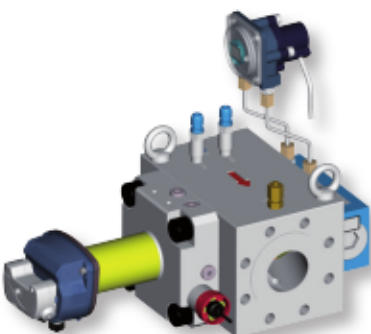

Delta DN50 G65 S1-Flow equipped with extension for the totaliser and by-pass

### Totaliser:

- » 9-digit index to register a larger volume
- » 45° orientation for an easy reading
- » Free-rotating totaliser
- » Equipped as standard with the cyble target: it allows the installation of the cyble sensor at any time.
- » Equipped with 1 built-in silicagel cartridge; as an option, equipped with an external cartridge to enable easy maintenance even in extreme conditions.
- » Fitted with a reflecting disc on the first drum.
- » Integrated optical disc to facilitate the periodic calibration of the meter.
- » Customised name plate (logo, bar-code, customer serial number...).
- » IP67 protection
- » UV resistant
- » Unit: m<sup>3</sup>



Universal totaliser fitted as standard with the Cyble target

### Transmitters:

- » Double Low Frequency fitted as standard on the whole range.
- » Anti-tampering is supplied as standard.
- » Medium Frequency is supplied as an option on the DN50 to DN150.
- » High Frequency is supplied as an option on the whole range.
- » Mechanical drive according to EN 12480 is supplied as an option.

### ACCESSORIES / OPTIONS

- » 100 µm flat **gasket-filter** to fit between flanges DN40 to DN150.

#### External silicagel cartridge:

- » Accessory for maintenance on the installed external silicagel cartridge for extreme conditions.

#### Pete's plug®:

- » Ideal device for filling lubricant in the cover of the meter while equipment is in service. It must be fitted instead of the tap plug of the cover. Plugged on the pressure tapping, it can be used to measure the pressure and the temperature of the measured gas. Connection size: ¼" NPT or ¼" BSP. Maximum pressure of gas: 20 bar.

#### Bracket for mounting a volume converter:

- » This device permits the Itron Corus PTZ volume converter to be adapted directly onto the meter, or at the most convenient place to the meter to enable the converter index to be easily read.

### Thermowells:

- » These threaded ¼" NPT thermowells, can be plugged onto the meter. They can be retrofitted on to the standard version (plugged onto the existing pressure tapping), or they can be installed on the versions equipped with extra-tapping. The internal diameter of the thermowell is 7 mm; it enables mounting of most standard temperature probes.

### Extension for the totaliser:

- » This option allows the possibility to increase the distance between the body of the meter and the index, to facilitate the reading when the meter is covered with ice due to measurement at low temperatures.

### By-pass:

- » It can be installed as an option on the steel version DN50. It enables the gas to flow even if the meter is blocked for any reason.

### Cyble sensor:

- » It can be delivered mounted onto the meter or installed afterwards at any time. The Cyble sensor is a bounce-free transmitter. It allows also the counting of eventual back flows.

## DELTA COMPACT - ALUMINIUM

### Main Characteristics

- » The Itron Compact DELTA meter is ideal for installation in extremely small cabinets.
- » Available in thread version (L=121mm) or flanged version (L=171mm).
- » Index can be oriented as required, magnetic coupling.
- » Multi-position meter, the flow orientation does not need to be specified when ordering the meter.
- » Only the front cover has to be filled with lubricant.
- » Thermowell: supplied as an option, 1 tapping 1/4" NPT allows an easy installation of a thermowell.
- » Double Low Frequency transmitter connected on a Binder 6 pins plug. Anti-tampering is supplied as a standard.
- » HF is supplied as an option, connected on a Binder 6 pins plug.
- » Equipped as standard with the Cyble target.

### Technical Features

Flow rate	0.25 m <sup>3</sup> /h to 65 m <sup>3</sup> /h
G size	G10, G16, G25 and G40
Rangeability	1:20 to 1:200
Threaded version	DN40 1/2" BSP or NPT
Flanged version	DN25*, DN40 and DN50 (1", 1 1/2", 2") ISO PN10/16, PN20* and ANSI125-ANSI150
Pressure range	Up to 19.3 bar

\* with minimum ordering quantity

### THREADED VERSION - Aluminium Range DN40:

G size	Qmax (m <sup>3</sup> /h)	DN	Flange to flange distance Dim.: L	Rangeability	Starting flow (dm <sup>3</sup> /h)	Flow rate at Error = -10% Typical value (dm <sup>3</sup> /h)	Pressure loss Δpr <sup>(1)</sup> (mbar)	1 Imp LF (m <sup>3</sup> /Imp)	1 Imp HF (dm <sup>3</sup> /Imp) (Std. Gears 32/40)	Freq HF at Qmax (Hz)	A	B	C	D	Vc (dm <sup>3</sup> )	Weight (Kg)
G10	16	40	121	20 to 50	25	60	0.3	0.01	0.218	20.4	126	46	172	126	0.19	4
G16	25	40	121	20 to 100	25	60	0.8	0.01	0.218	31.8	126	46	172	126	0.19	4
G25	40	40	121	20 to 160	25	60	1.8	0.01	0.218	50.9	126	46	172	126	0.19	4
G40	65	40	121	20 to 200	25	60	4.8	0.01	0.218	82.8	126	46	172	126	0.19	4

<sup>(1)</sup>Δpr: Pressure loss (mbar) with ρ = 0.83Kg/m<sup>3</sup> and at Qmax



Delta DN40 G16



Delta DN40 G16 fitted with Cyble sensor

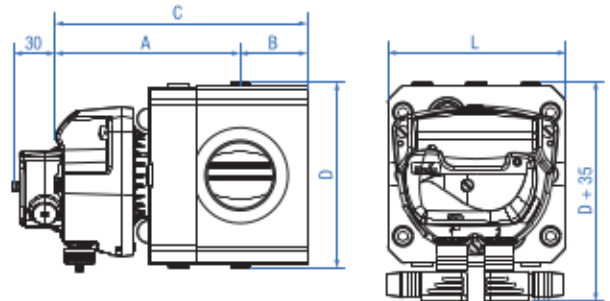

### FLANGED VERSION - Aluminium Range DN25/DN40/DN50:

G size	Qmax (m <sup>3</sup> /h)	DN	Flange to flange distance Dim.: L	Rangeability	Starting flow (dm <sup>3</sup> /h)	Flow rate at Error = -10% Typical value (dm <sup>3</sup> /h)	Pressure loss Δpr <sup>(1)</sup> (mbar)	1 Imp LF (m <sup>3</sup> /Imp)	1 Imp HF (dm <sup>3</sup> /Imp) (Std. Gears 32/40)	Freq HF at Qmax (Hz)	A	B	C	D	Vc (dm <sup>3</sup> )	Weight (Kg)
G10	16	25*	171	20 to 50	25	60	0.4	0.01	0.218	20.4	126	60	186	126	0.19	6
G10	16	40	171	20 to 50	25	60	0.3	0.01	0.218	20.4	126	60	186	126	0.19	6
G10	16	50	171	20 to 50	25	60	0.3	0.01	0.218	20.4	126	60	186	126	0.19	6
G16	25	25*	171	20 to 100	25	60	0.8	0.01	0.218	31.8	126	60	186	126	0.19	6
G16	25	40	171	20 to 100	25	60	0.7	0.01	0.218	31.8	126	60	186	126	0.19	6
G16	25	50	171	20 to 100	25	60	0.6	0.01	0.218	31.8	126	60	186	126	0.19	6
G25	40	40	171	20 to 160	25	60	1.8	0.01	0.218	50.9	126	60	186	126	0.19	6
G25	40	50	171	20 to 160	25	60	1.6	0.01	0.218	50.9	126	60	186	126	0.19	6
G40	65	40	171	20 to 200	25	60	4.5	0.01	0.218	82.8	126	60	186	126	0.19	6
G40	65	50	171	20 to 200	25	60	4.2	0.01	0.218	82.8	126	60	186	126	0.19	6

<sup>(1)</sup>Δpr: Pressure loss (mbar) with ρ = 0.83Kg/m<sup>3</sup> and at Qmax

\* with minimum ordering quantity



Delta DN50 G40



Delta DN50 G40 fitted with Cyble sensor

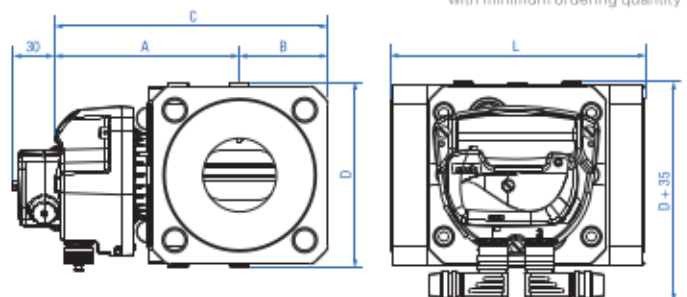

## DELTA 2050/2080/2100 - ALUMINIUM

### Main Characteristics

- » Index can be oriented as required, magnetic coupling.
- » Both front and rear covers must be filled with a lubricant.
- » Multi-position meters, the flow orientation does not need to be specified when ordering the meter.
- » Thermowells: supplied as an option, 2 tapings 1/4" NPT allow an easy installation of thermowells.
- » Double Low Frequency transmitter connected on a Binder 6 pins plug. Anti-tampering is supplied as a standard.
- » MF is supplied as an option.
- » HF is supplied as an option, connected on a 3 pin binder.
- » A G100 DN50 is available to allow the possibility of increasing the station capacity; the use of the same flanging as the G65 DN50 does not require modification of the existing installation.
- » Equipped as standard with the Cyble target.

### Technical Features

Flow rate	0.4 m <sup>3</sup> /h to 400 m <sup>3</sup> /h
G size	G16, G25, G40, G65, G100, G160 and G250
Rangeability	1:20 to 1:200
Nominal diameter	50, 80 and 100 (2", 3" and 4")
Flanging	PN 10/16, PN20 and ANSI125-ANSI150
Pressure range	16 bar (Option: 19.3 bar)

### Aluminium Range DN50/DN80/DN100:

G size	Qmax (m <sup>3</sup> /h)	DN	Flange to flange distance Dim.: L	Rangeability	Starting flow (dm <sup>3</sup> /h)	Flow rate at: Error $\approx$ -10% Typical value (dm <sup>3</sup> /h)	Pressure loss $\Delta p$ <sup>1)</sup> (mbar)	1 Imp LF & Cyble (m <sup>3</sup> /Imp)	1 Imp MF (m <sup>3</sup> /Imp)	Freq MF at Qmax (Hz)	1 Imp HF (dm <sup>3</sup> /Imp) (Std. Gears 32/40)	Freq HF at Qmax (Hz)	A	B	C	D	Vc (dm <sup>3</sup> )	Weight (Kg)
G16	25	50	171	20 to 50	50	150	0.13	0.1	2.72	2.55	0.0585	119	190	121	311	182	0.59	11
G25	40	50	171	20 to 100	50	150	0.33	0.1	2.72	4.08	0.0585	190	190	121	311	182	0.59	11
G40	65	50	171	20 to 160	50	150	0.88	0.1	2.72	6.64	0.0585	309	190	121	311	182	0.59	11
G65	100	50	171	20 to 200	50	150	2.08	0.1	2.72	10.2	0.0585	475	190	121	311	182	0.59	11
G65	100	80	171	20 to 200	70	250	0.69	0.1	4.36	6.36	0.0939	296	228	159	387	182	0.94	15
G100	160	50	171	20 to 200	70	250	3.25	0.1	4.36	10.2	0.0939	473	228	159	387	182	0.94	15
G100	160	80	171	20 to 200	70	250	1.73	0.1	4.36	10.2	0.0939	473	228	159	387	182	0.94	15
G160	250	80	171	20 to 200	80	250	3.15	0.1	5.28	13.2	0.116	599	252	183	435	182	1.16	17
G160	250	80	241	20 to 160	150	500	2.73	0.1	8.26	8.41	0.178	390	230	179	409	235	1.78	29
G160	300	100	241	20 to 160	175	550	2.1	1	21.8	3.82	0.241	346	265	213	478	235	2.41	34
G250	400	100	241	20 to 160	200	600	2.63	1	32.6	3.40	0.365	304	333	282	615	235	3.65	43

<sup>1)</sup> $\Delta p$ : Pressure loss (mbar) with  $\rho = 0.83\text{Kg/m}^3$  and at Qmax



Delta DN100 G250 in aluminium equipped with HF and Cyble sensor

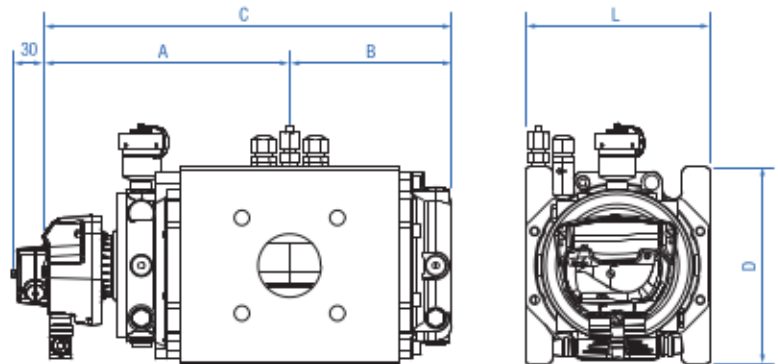

**DELTA 2050/2080/2100 & S3-FLOW - DUCTILE IRON - EN-GJS-400-18LT**
**Main Characteristics**

- » Index can be oriented as required, magnetic coupling.
- » Both front and rear covers must be filled with a lubricant.
- » Multi-position meters, the flow orientation does not need to be specified when ordering the meter.
- » Thermowells: supplied as an option, 2 tapings 1/4" NPT allow an easy installation of thermowells.
- » Double Low Frequency transmitter connected on a Binder 6 pins plug. Anti-tampering is supplied as a standard.
- » MF is supplied as an option.
- » HF is supplied as an option (up to 3 HF possible for the S3-Flow!).
- » High Temperature Loading: fire resistant PN5 is supplied as an option.
- » Equipped as standard with the Cyble target.

**Technical Features**

Flow rate	0.4 m <sup>3</sup> /h to 1000 m <sup>3</sup> /h
G size	G16, G25, G40, G65, G100, G160, G250, G400 and G650
Rangeability	1:20 to 1:200
Nominal diameter	50, 80, 100 and 150 (2", 3", 4" and 6")
Flanging	PN 10/16, PN20 and ANSI150
Pressure range	16 bar (Option: 19.3 bar)

**Ductile iron Range DN50/80/100/150:**

G size	Qmax (m <sup>3</sup> /h)	DN	Flange to flange distance Dim.: L	Rangeability	Starting flow (dm <sup>3</sup> /h)	Flow rate at: Error = -10% Typical value (dm <sup>3</sup> /h)	Pressure loss Δpr <sup>(1)</sup> (mbar)	1 Imp LF & Cyble (m <sup>3</sup> /Imp)	1 Imp MF (m <sup>3</sup> /Imp)	Freq MF at Qmax (Hz)	1 Imp HF (dm <sup>3</sup> /Imp) (Std. Gears 32/40)	Freq HF at Qmax (Hz)	A	B	C	D	Vc (dm <sup>3</sup> )	Weight (Kg)
G16	25	50	150	20 to 50	70	250	0.1	0.1	4.36	1.59	0.0939	74	228	150	378	174	0.94	25
G16	25	50	171	20 to 50	50	150	0.13	0.1	2.72	2.55	0.0585	119	190	112	302	174	0.59	19
G25	40	50	150	20 to 100	70	250	0.21	0.1	4.36	2.55	0.0939	118	228	150	378	174	0.94	25
G25	40	50	171	20 to 100	50	150	0.33	0.1	2.72	4.08	0.0585	190	190	112	302	174	0.59	19
G40	65	50	150	20 to 160	70	250	0.55	0.1	4.36	4.14	0.0939	192	228	150	378	174	0.94	25
G40	65	50	171	20 to 160	50	150	0.88	0.1	2.72	6.64	0.0585	309	190	112	302	174	0.59	19
G65	100	50	150	20 to 200	70	250	1.3	0.1	4.36	6.36	0.0939	296	228	150	378	174	0.94	25
G65	100	50	171	20 to 200	50	150	2.08	0.1	2.72	10.2	0.0585	475	190	112	302	174	0.59	19
G65	100	80	171	20 to 200	70	250	0.69	0.1	4.36	6.36	0.0939	296	228	150	378	194	0.94	25
G65	100	80	230	20 to 80	80	250	0.52	0.1	5.28	5.26	0.116	239	252	174	426	225	1.16	30
G65	100	80	240	20 to 200	70	250	0.69	0.1	4.36	6.36	0.0939	296	228	150	378	194	0.94	27
G100	160	50	150	20 to 200	70	250	3.25	0.1	4.36	10.2	0.0939	473	228	150	378	194	0.94	25
G100	160	80	171	20 to 200	70	250	1.73	0.1	4.36	10.2	0.0939	473	228	150	378	194	0.94	25
G100	160	80	230	20 to 130	80	250	1.32	0.1	5.28	8.42	0.116	383	252	174	426	225	1.16	30
G100	160	80	240	20 to 200	70	250	1.73	0.1	4.36	10.2	0.0939	473	228	150	378	194	0.94	27
G100	160	80	310	20 to 100	150	500	1.15	0.1	8.26	5.38	0.178	250	230	179	409	235	1.78	45
G100	160	100	241	20 to 130	80	250	0.9	0.1	5.28	8.42	0.116	383	252	174	426	225	1.16	30
G160	250	80	230	20 to 200	80	250	3.15	0.1	5.28	13.2	0.116	599	252	174	426	225	1.16	30
G160	250	80	241	20 to 160	150	500	2.73	0.1	8.26	8.41	0.178	390	230	179	409	235	1.78	41
G160	250	80	310	20 to 160	150	500	2.73	0.1	8.26	8.41	0.178	390	230	179	409	235	1.78	45
G160	250	100	230	20 to 200	80	250	2.2	0.1	5.28	13.2	0.116	599	252	174	426	225	1.16	30
G160	250	100	241	20 to 200	80	250	2.2	0.1	5.28	13.2	0.116	599	252	174	426	225	1.16	30
G250	400	100	241	20 to 160	200	600	2.63	1	32.6	3.40	0.365	304	333	282	615	235	3.65	56
G250	400	100	400	20 to 160	200	600	2.63	1	32.6	3.40	0.365	304	333	282	615	235	3.65	61
G250	400	150 <sup>(2)</sup>	450	20 to 100	400	1000	0.77	1	48.0	2.31	0.595	187	343	267	610	365	5.4	120
G400	650	150 <sup>(2)</sup>	450	20 to 160	400	1000	2.03	1	48.0	3.76	0.595	303	343	267	610	365	5.4	120
G650	1000	150 <sup>(2)</sup>	450	20 to 200	400	1000	4.8	1	48.0	5.79	0.595	467	343	267	610	365	5.4	120

<sup>(1)</sup>Δpr: Pressure loss (mbar) with ρ = 0.83Kg/m<sup>3</sup> and at Qmax  
<sup>(2)</sup>S3-Flow meter



Delta DN80 G100 3xDN in Ductile iron equipped with Cyble sensor

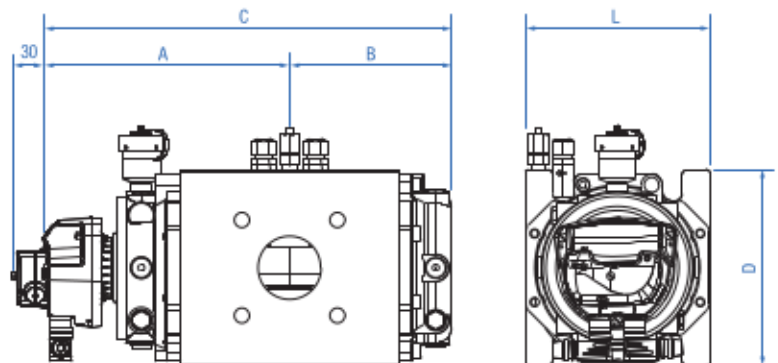

## DELTA S1-FLOW - STEEL

### Main Characteristics

- » Index can be oriented as required, magnetic coupling.
- » Double Low Frequency transmitter connected on a 6 pin Binder plug. Anti-tampering is supplied as a standard.

### DN50

- » G16 to G100
- » S-Flow technology
- » Only the front cover must be filled with a lubricant.
- » Multi-position meter
- » MF is supplied as an option.
- » 2 thermowells are supplied as option.
- » A by-pass can be installed as an option. It enables the gas to flow even if the meter is blocked for any reason.
- » An alarm can be remotely sent requesting for maintenance.
- » Up to 2 HF are supplied as option.

### Technical Features

Flow rate	0.4 m <sup>3</sup> /h to 160 m <sup>3</sup> /h
G size	G16, G25, G40, G65 and G100
Rangeability	1:20 to 1:200
Nominal diameter	50 (2")
Flanging	PN 10/16 to PN110, ANSI 150 to ANSI600
Pressure range	101.2 bar

### Steel Range DN50:

G size	Qmax (m <sup>3</sup> /h)	DN	Flange to flange distance Dim.: L	Rangeability	Starting flow (dm <sup>3</sup> /h)	Flow rate at: Error = -10% Typical value (dm <sup>3</sup> /h)	Pressure loss Δpr <sup>1)</sup> (mbar)	1 Imp LF & Cyble (m <sup>3</sup> /Imp)	1 Imp MF (m <sup>3</sup> /Imp)	Freq MF at Qmax (Hz)	1 Imp HF (dm <sup>3</sup> /Imp) (Std. Gears 32/40)	Freq HF at Qmax (Hz)	A	B	C	D	Vc (dm <sup>3</sup> )	Weight (Kg)
G16	25	50	240	20 to 30	50	150	0.09	0.1	2.31	3.01	0.0496	140	190	100	290	150	0.49	34
G25	40	50	240	20 to 65	50	150	0.23	0.1	2.31	4.81	0.0496	224	190	100	290	150	0.49	34
G40	65	50	240	20 to 100	50	150	0.6	0.1	2.31	7.82	0.0496	364	190	100	290	150	0.49	34
G65	100	50	240	20 to 160	50	150	1.42	0.1	2.31	12.0	0.0496	560	190	100	290	150	0.49	34
G100	160	50	240	20 to 200	50	150	3.64	0.1	2.31	19.3	0.0496	896	190	100	290	150	0.49	34

<sup>1)</sup>Δpr: Pressure loss (mbar) with ρ = 0.83Kg/m<sup>3</sup> and at Qmax

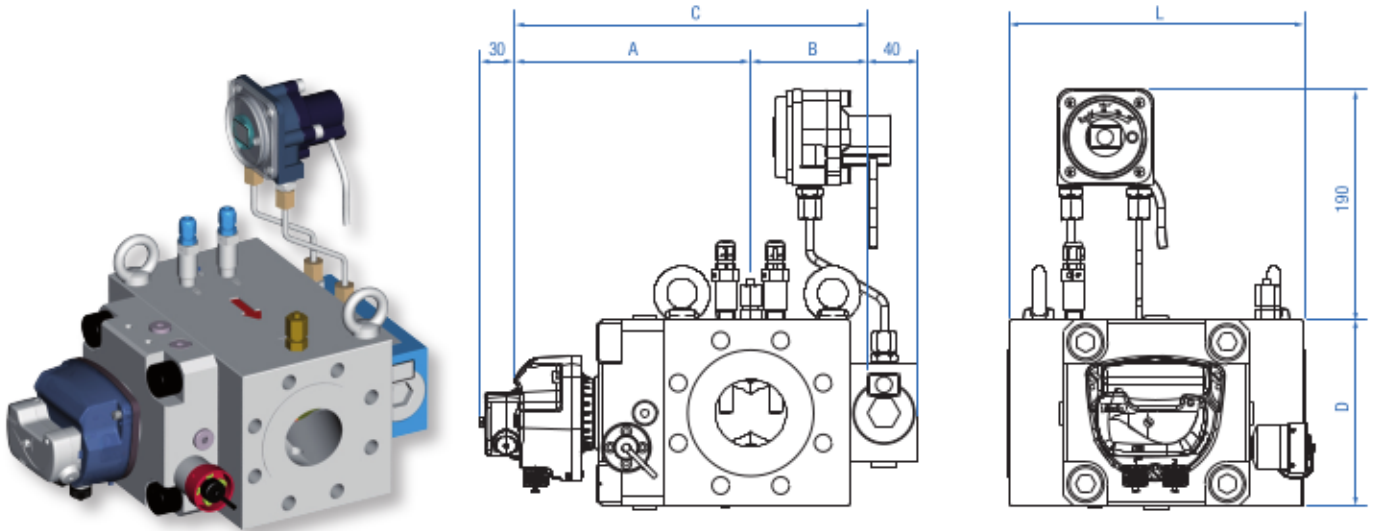

Delta DN50 G65 S1 Flow in steel and equipped with by-pass

## A) TRANSMITTER CHARACTERISTICS

Intrinsic safety approval: L.C.I.E. 06 ATEX 6031 X  
Intrinsic safety level: Ex II 1/2 G Ex ia IIC T5 c T6

### Low Frequency pulse transmitters (LF):

The LF transmitter consists of 2 dry Reed switches, normally open, and controlled by a magnet situated in the first drum of the totaliser. The LF connections are without polarity.

#### 1) Internal Reed contacts

- » Hermetically sealed contacts
  - Maximum terminal voltage: 30 Volt and maximum current according to EN 60079-11.
- » Ambient temperature  
Ta = -30°C to +60°C
- » Minimum pulse time: 0.4 s

#### 2) Cyble sensor

- » It conforms to CENELEC standard EN 60079-11 with:
  - Ui ≤ 14.3 Volt
  - Ii ≤ 50 mA

### Inductive transmitters (HF and MF):

They are inductive sensors actuated by a toothed disc. The frequency is proportional to the instantaneous flow. The polarity of the connections is indicated on the name plate of the meter.

#### 1) High Frequency transmitters

- » Proximity detectors conform to EN 60947-5-6 (NAMUR) standards.
- » They conform to CENELEC standards (EN 60079-0 and EN 60079-11) with:
  - Ui ≤ 15 Volt
  - Ii ≤ 50 mA
  - Ci ≤ 90 nF
  - Li ≤ 100 µH
  - Pi ≤ 120 mW
- » Ambient temperature  
Ta = -30°C to +60°C

#### 2) Medium Frequency transmitter

- » It conforms to CENELEC standards (EN 60079-0 and EN 60079-11) with:
  - Ui ≤ 16 Volt
  - Ii ≤ 52 mA
  - Ci ≤ 50 nF
  - Li ≤ 250 µH
  - Pi ≤ 64 mW



Delta DN150 G650 S3-Flow in Ductile iron

### Anti-tampering transmitter (AT):

This consists of one dry Reed switch, normally closed. Attempts at magnetic tampering will open the contact. The electrical characteristics are the same as those for the LF transmitter.

## B) PRESSURE LOSS OF THE DELTA METERS

Calculation of pressure loss:  $\Delta p = \Delta p_r \times \frac{\rho n}{0.83} \times (P_b + 1) \times \left[ \frac{q}{Q_{max}} \right]^2 \times \left[ \frac{273}{273 + T_b} \right]$

## C) INSTALLATION

Each meter is delivered with binder plugs for the installed transmitters and oil for the lubrication. Please refer to the instruction manual supplied with the meter.

The advice given therein will ensure optimal use of the Delta meter over the years.

### where:

- Δp: Pressure loss in the calculated conditions
- Δpr: Pressure loss in the reference conditions
- ρn: Gas density (kg/m<sup>3</sup>) at 0° C and 1013 mbar
- Pb: Operating pressure (Bar gauge)
- q: Flow rate (m<sup>3</sup>/h)
- Qmax: Maximum flow rate (m<sup>3</sup>/h)
- Tb: Gas temperature (°C).