

CHANGEOVER VALVES CATALOG

FEMA CAT02 Rev.3 April 2014



TABLE OF CONTENTS

0. GENERAL	2
1. RISK FACTORS.....	2
2. CLASSIFICATION.....	3
3. TEST.....	5
4. MARKING.....	5
CHANGEOVER VALVES TYPE 4000	6
MECHANICAL CHARACTERISTICS	7
INTERLOCKED CHANGEOVER VALVES TYPE 4100.....	11
CHANGEOVER VALVES TYPE 4300	16
Figure 1 – Valve S. 4000	7
Figure 2 – Disc - Stem Coupling.....	8
Figure 3 – CHANGEOVER valve S. 4000 with reducer	8
Figure 4 – CHANGEOVER valve S. 4000 with pneumatic actuator.....	8
Figure 5 – Perpendicularly coupled interlocked CHANGEOVER valves assembly.....	12
Figure 6 – Reducers	13
Figure 7 – Interlocked CHANGEOVER valves assembly	14
Figure 8 – CHANGEOVER valve Type 4300.....	17
Table 1 – Classification.....	4
Table 2 – Material selection Type 4000	9
Table 3 – Dimensions and Weights Type 4000	10
Table 4 – Dimensions and Weights Type 4100	15
Table 5 – Material selection Type 4300	18
Table 6 – Dimensions and Weights Type 4300	19

GENERAL

The CHANGEOVER valves are three-way on-off valves.

The inlet way, featuring a connection flange facing downwards, represents the central section, whereas the outlet ways are the side bends and feature connection flanges facing upwards and are marked by numbers 1 and 2 respectively.

These valves have been designed to accommodate two safety valves, featuring equal dimensions and calibration:

- one for uninterrupted operation, to protect a plant;
- the second one operating as a stand-by valve, normally not in operation, the function of which is to take the place of the former one, should abnormal conditions or considerable losses be experienced thereon.

The CHANGEOVER valves are designed and manufactured in accordance with the following standards and conform to the provisions of directives 97/23/CE (PED) and 94/9/CE (ATEX):

API 520	calculations – engineering – installation
API 598	seal test
ASME B16.5	flange engineering – hydraulic test
ASME B 16.34	body thickness
ASTM/UNI	materials

RISK FACTORS

The valve-related risks, and particularly those related to valve configuration, are carefully considered when designing them, on the basis of the applicable regulations, without introducing significant innovations. Specifically:

- **Configuration:** Reference is made to the configurations specified in the API 520 and ASME B16.34 and ASME B16.5 standards. Also, their drawing is particularly simple, so as to make it easier to operate, maintain, mount, and control the valves.
- **Manufacturing methods:** The manufacturing methods are fully consolidated and don't present any risk or uncertainty factor. Their manufacturing technology is used at Fema for many years, and nothing unknown is associated therewith.
- **Tests:** Tests on materials and production, particularly during the mounting phase, as specified by company procedures, assure quality of the products and compliance with the applicable requirements.
- **Materials:** The materials used conform to the ASME B 16.34 reference standards.
- **Operating product analysis:** So far, no significant malfunctions have been reported on the valves produced by Fema over 50 years of activity.

Installation-related risks

The CHANGEOVER valve installation modes are correctly described in the instruction manual and conform to simple safety and operativeness criteria according to the provisions of the API 520, part 2nd standard.

Use-related risks

The use of the CHANGEOVER valves of the same types as those manufactured by FEMA is not conditional on a special knowledge thereof, in addition to what described in the instruction manual.

The function of a CHANGEOVER valve is just to make maintenance possible on safety valves without being obliged to stop the plant.

Further potential risks resulting from:

- ❖ valve abnormalities or malfunctions
- ❖ their installation
- ❖ their use

are described in the instruction manual.

CLASSIFICATION

The CHANGEOVER valves of series 4000 include the following types:

- 4000 Single CHANGEOVER valve – flanged
- 4100 Double CHANGEOVER valve 4000, of which: 1 vertical valve and 1 horizontal valve, interlocked
- 4300 Single CHANGEOVER valve – threaded

Concerning Directive 97/23/CE (PED), the CHANGEOVER valves switch from the off status to category III, as a function of their engineering data and pressures, as specified in Table 1 below.

Concerning Directive **94/9/CE (ATEX)**, they are classified as Apparatuses of Group II, Cat. 2G.

Table 1 – Classification (according to Table 6 PED)

DN	CLASS	CATEGORY	EVALUATION PROCEDURE	NOTE
3/4" x 3/4" x 3/4"		Off	A	Article 3, paragraph 3
1" x 1" x 1"		Off	A	Article 3, paragraph 3
1"1/2 x 1"1/2 x 1"1/2	150	I	B+D	
	300 to 2500	I	B+D	
2" x 2" x 2"	150	I	B+D	
	300 to 2500	II	B+D	
2"1/2 x 2"1/2 x 2"1/2	150 to 600	II	B+D	
3" x 3" x 3"	150 to 1500	II	B+D	
4" x 4" x 4"	150 to 1500	II	B+D	
6" x 6" x 6"	150	II	B+D	
	300 to 600	III	B+D	
8" x 8" x 8"	150	II	B+D	
	300	III	B+D	
10" x 10" x 10"	150 to 300	III	B+D	
12" x 12" x 12"	150	III	B+D	
14" x 14" x 14"	150	III	B+D	
16" x 16" x 16"	150	III	B+D	

TEST:

The valves are tested according to the Fema STD-602 standard and conform to the provisions of the API 598 -1996 specification.

An hydraulic test is performed according to the Fema STD-606 standard. The pressure value adopted for the hydraulic test is 1.5 times the max. value specified for the operating pressure. This way, the PED – Attachment 1, para. 7.4 Directive's requirement, which specifies a ratio between the test pressure and the max. operating pressure of 1.43, is conformed to.

MARKING:

A stainless steel label is secured to every valve and specifies the values for the main functional and manufacturing characteristics in accordance with the API 526 Appendix B standards and in accordance with the provisions of Attachment I to paragraph 3.3 and of Attachment VII of the PED Directive.



The valves are marked CE N° 1115 and are accompanied by an EC Conformity Statement according to Attachment VII of Directive 97/23/CE (PED).



Further, upon a customer's request, the valves might be marked in accordance with the ATEX

Directive, with the hexagonal symbol , Group II Category 2, as well as with the danger type G (gas).



CHANGEOVER VALVES S. 4000/78

- MECHANICAL CHARACTERISTICS
- MATERIAL SELECTION
- DIMENSIONS

MECHANICAL CHARACTERISTICS STRUCTURE

The basic configuration of a CHANGEOVER valve comprises the following component parts:

- CENTRAL BODY (1)
Process flow inlet, comprising a connection flange with the ratings specified for its coupling to the plant.
- LEFT BEND 1 and RIGHT BEND 2 (2)
Process flow outlet, each complete with two flanges. The side flanges are coupled to the central body by stud bolts, with grinded and lapped mouthpieces to obtain the seal seat. The upper flange is engineered according to the ratings suitable for safety valve coupling.
- DISC (4)
Its function is to switch either safety valve off.
It features a cylindrical shape and its two opposing seats are grinded and lapped.
- CONTROL ROD (7)
The control rod is arranged horizontally, is not revolving but rather translating through bend 2 and is coupled to the disc by a threaded fitting and a ring formed of two half-rings. A handwheel-operated nut screw operates onto the threaded section.
- NUT SCREW (21)
The nut screw is revolving and operates as a handwheel-holder. It is secured to the supporting flange by a threaded fitting.
- POSITION INDICATOR BLOCK (17)
It is pushed onto the control rod and slides on either pillar. The function performed by it is twofold: keeping the rod fixed, to prevent it from rotating, and indicating the disc position.

Figure 1 – Valve Type 4000

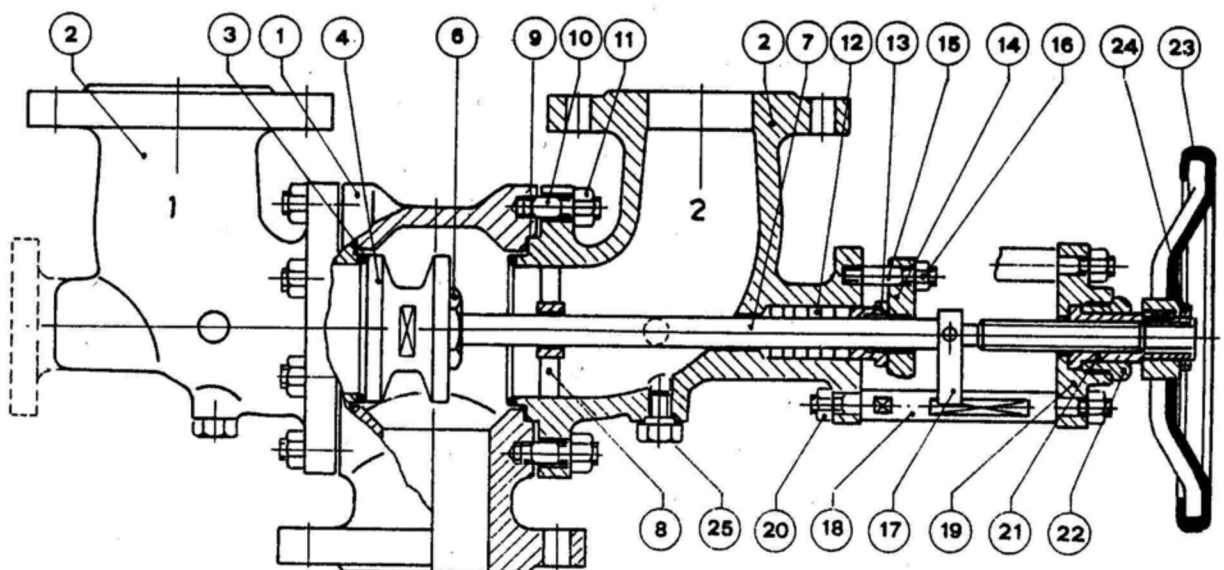

Figure 2 – Disc – Stem Coupling



Figure 3 – CHANGEOVER valve 4000 with reducer

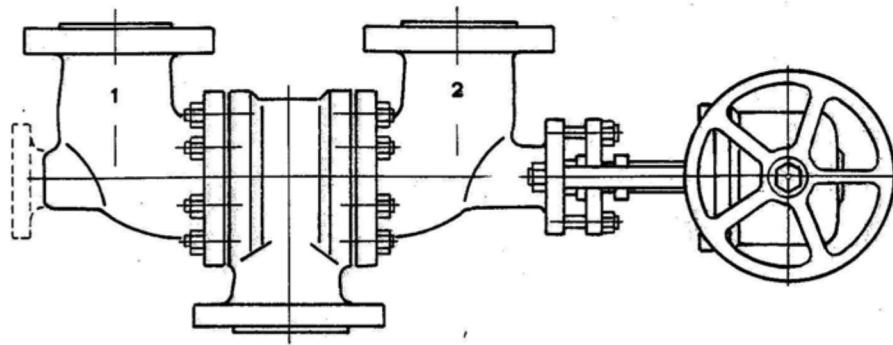

Figure 4 – CHANGEOVER valve 4000 with pneumatic actuator

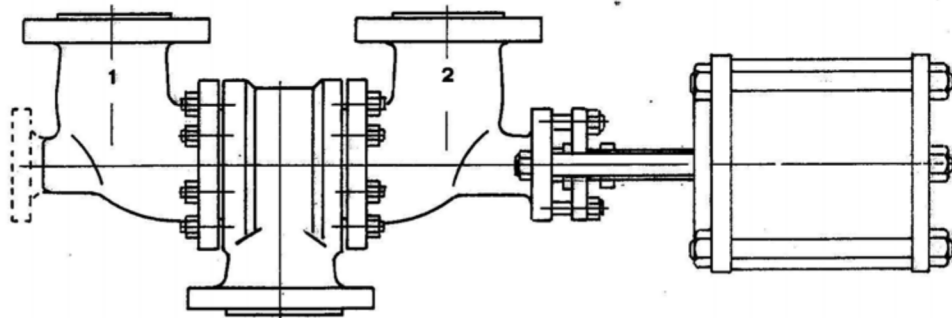



Table 2 – MATERIAL SELECTION AS A FUNCTION OF TEMPERATURE

POS.	PARTS	4000 – SS -269 to -61°C	4000 – SN -269 to -61°C	4000 – WN -60 to -46°C	4000 – LN -45 to -29°C	4000 – LN -28 to -22°C
1	INLET BODY	ASTM A351 CF8M	ASTM A351 CF8	ASTM A352 LC1	ASTM A352 LCB	ASTM A479 TP 304 (1)
2	OUTLET BENDS					
3	SEATS					
4	DISC	ASTM A479 TP 316	ASTM A479 TP 304			ASTM A479 TP 304
5	RING (FORMED OF TWO HALF-RINGS)					
6	DISC FITTING					
7	ROD					
8	ROD GUIDE					
9	BODY GASKET	K.SIL.C-4400				
10	BODY TIE RODS	ASTM A479 TP 304				
11	BODY LOCKING NUTS	ASTM A479 TP 303				
12	PACKING NIPPLE GASKET	PTFE				
13	PACKING NIPPLE		ASTM A479 TP 304			
14	PACKING NIPPLE FLANGE	ASTM A479 TP 304				
15	PACKING NIPPLE FLANGE TIE RODS	ASTM A479 TP 304				
16	PACKING NIPPLE FLANGE LOCKING NUTS	ASTM A479 TP 304				
17	POSITION INDICATOR	STEEL UNIEN 10025				
18	PILLARS	ASTM A479 TP 304				
19	NUT SCREW HOLDER FLANGE	STEEL UNIEN 10025				
20	PILLAR LOCKING NUTS	ASTM A479 TP 304				
21	NUT SCREW	Bronze UNI 1982				
22	NUT SCREW FITTING	STEEL UNIEN 10025				
23	HANDWHEEL					
24	HANDWHEEL LOCKING NUT					
25	DRAINING PLUG		ASTM A479 TP 304			
	SCREWS		ASTM A479 TP 304			

(1) = Electrically welded seats

(2) = For dimensions from 6" and more: A 105 with AISI 304

Dimensions and weights

The dimensions and weights indicated below are approximate.

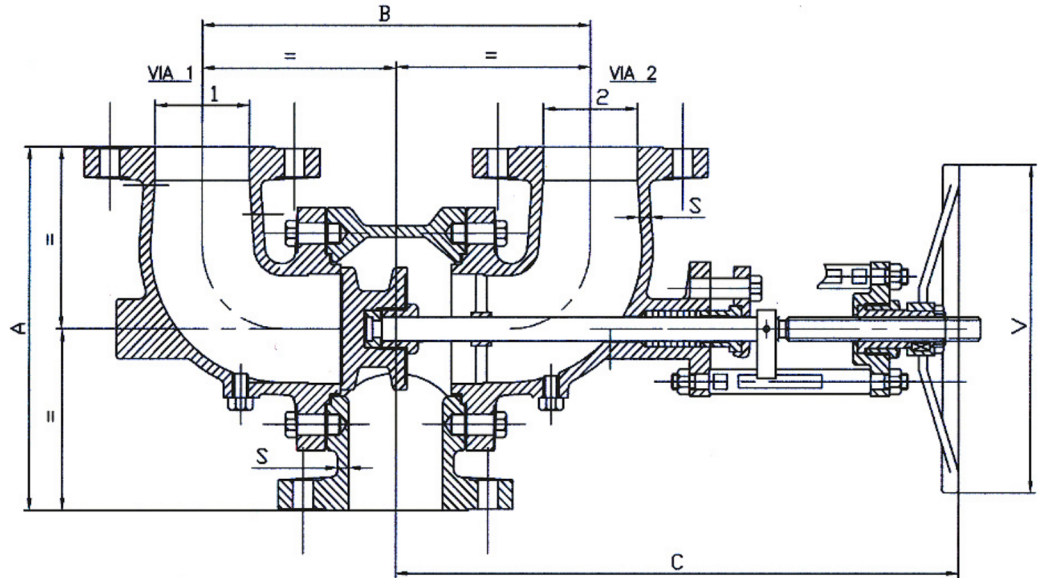

Tab. 3

INLET/OUTLET CONNECTIONS		INLET/OUTLET RATINGS	THROUGH AREAS Way 1 & Way 2	OVERALL DIMENSIONS				WEIGHT	Body and Bend Thickness
ANSI Inches	ANSI Inches	ANSI-CLASS	cm ²	A mm	B mm	C mm	V mm	Kg	(S) mm
¾ to 1	¾ to 1	150 to 300	5.1	230	220	340	175	20	9
¾ to 1	¾ to 1	600	5.1	244	220	340	175	22	9
1 1/2	1 1/2	150 to 300	12.6	250	270	420	225	40	10.5
1 1/2	1 1/2	600	12.6	263	270	420	250	40	10.5
1 1/2	1 1/2	900 to 1500	12.6	300	340	460	250	73	16
1 1/2	1 1/2	2500	12.6	420	400	485	300	90	26
2	2	150 to 300	20.3	280	310	445	225	50	12
2	2	600	20.3	293	310	445	250	50	12
2	2	900 to 1500	20.3	360	370	485	250	106	20
2 1/2	2 1/2	150 to 300	33.2	310	335	540	300	80	13.5
3	3	150 to 300	50.3	340	365	550	300	90	13.5
3	3	600	50.3	353	365	550	300	90	13.5
3	3	900	50.3	480	500	610	350	160	20
3	3	1500	50.3	480	500	610	350	180	24.5
4	4	150 to 300	81.1	380	420	595	350	120	13.5
4	4	600	81.1	420	480	665	350	165	16.5
4	4	900	81.1	516	520	700	400		22.5
4	4	1500	81.1	516	520	700	400		22.5
4	4	2500	81.1	700	900	890	400		37.5
6	6	150	182.4	460	540	755	400	185	13
6	6	300	182.4	460	540	755	400	225	17
6	6	600	182.4	560	660	815	400	380	20
8	8	150	324.2	550	700	900	500	360	13.5
8	8	300	324.2	580	700	900	500	390	18.5
10	10	150	506.5	600	840	1000	500	425	15.5
10	10	300	506.5	630	840	1000	500		15.5
12	12	150	729.3	640	860	1115	600	470	17
14	14	150	992.7	720	1000	1220	600		18
16	16	150	1296.6	800	1160	1320	600		19



INTERLOCKED CHANGEOVER VALVES TYPE 4100

- MECHANICAL CHARACTERISTICS
- DIMENSIONS

The valves type 4100 are an interlocked valves assembly in which two CHANGEOVER valves type 4000 are mounted upstream and downstream two safety valves respectively, each operating as a stand-by valve with respect to the other.

Such an assembly comprises the following component parts:

- 1 Primary CHANGEOVER valve called **CV1**.
- 2 Safety valves mounted at the outlets of primary valve **CV1**.
- 2 Flanged sections coupled to the outlet flanges of the safety valves.
- 1 Secondary CHANGEOVER valve called **CV2**, connected to the outlet sections of the safety valves.

The control rods of the CHANGEOVER valves are mechanically interconnected to each other, in such a way as to allow a paired and simultaneous control.

Operating the handwheel located on the inlet valve results in the simultaneous operation of the two valves, whereby the functions of the two ways are switched over and either safety valve is switched off.

A lever is located on the outlet valve and allows to compensate for the unavoidable mechanical clearances and manufacturing tolerances.

Figure 5 - Perpendicularly coupled interlocked CHANGEOVER valves assembly

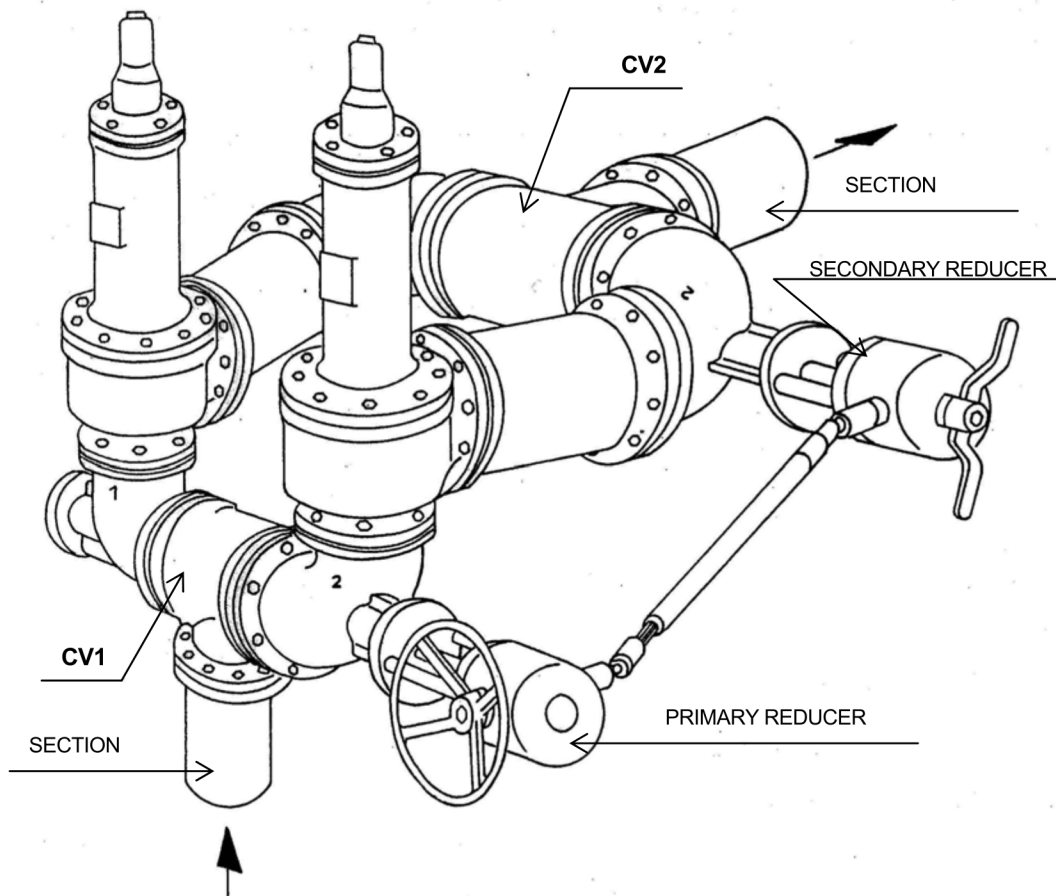
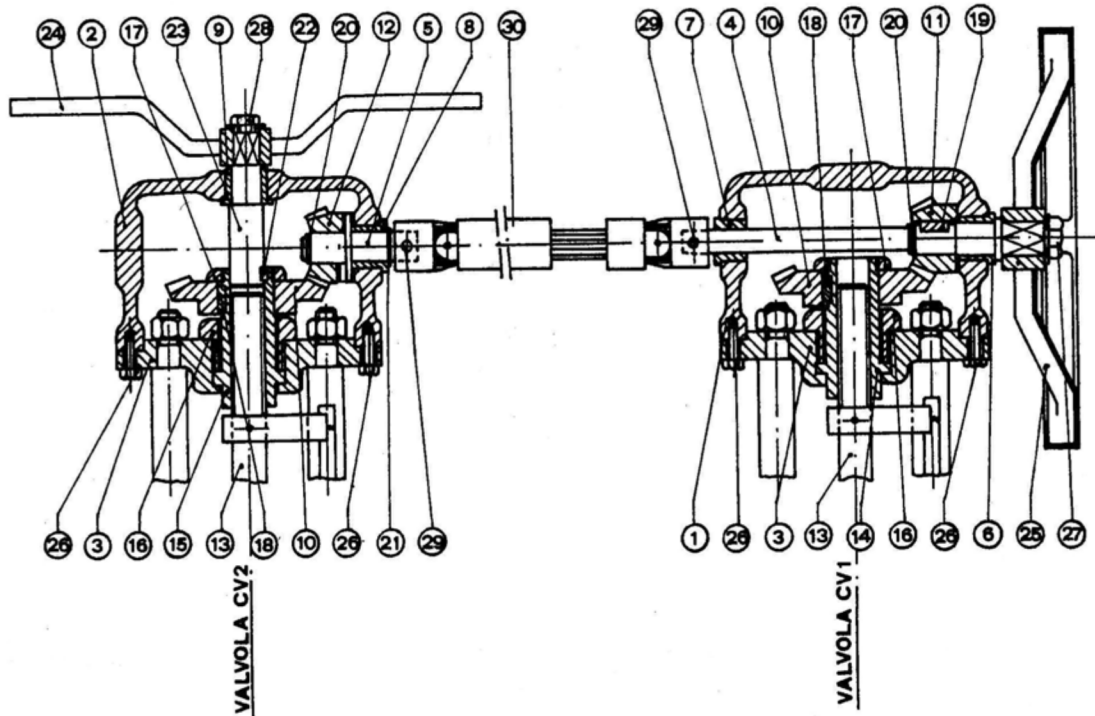

Fig. 6 – Reducers



POS. DESCRIPTION

- 1 Primary reducer box
- 2 Secondary reducer box
- 3 Supporting flange
- 4 Primary pivot
- 5 Secondary pivot
- 6 Bush
- 7 Bush
- 8 Bush
- 9 Bush
- 10 Gearwheel
- 11 1st pivot pinion
- 12 2nt pivot pinion
- 13 Control rod
- 14 Primary reducer nut screw
- 15 Secondary reducer nut screw

POS. DESCRIPTION

- 16 Nut screw stop fitting
- 17 Stop ring nut
- 18 Key
- 19 Key
- 20 Spring ring
- 21 Spring ring
- 22 Key
- 23 Clearance recovery pivot
- 24 Clearance recovery lever
- 25 Handwheel
- 26 Hexagonal-head screw
- 27 Hexagonal-head screw + washer
- 28 Hexagonal-head screw + washer
- 29 Spring plug
- 30 Extendable shaft

Figure 7 – Interlocked CHANGEOVER valves assembly

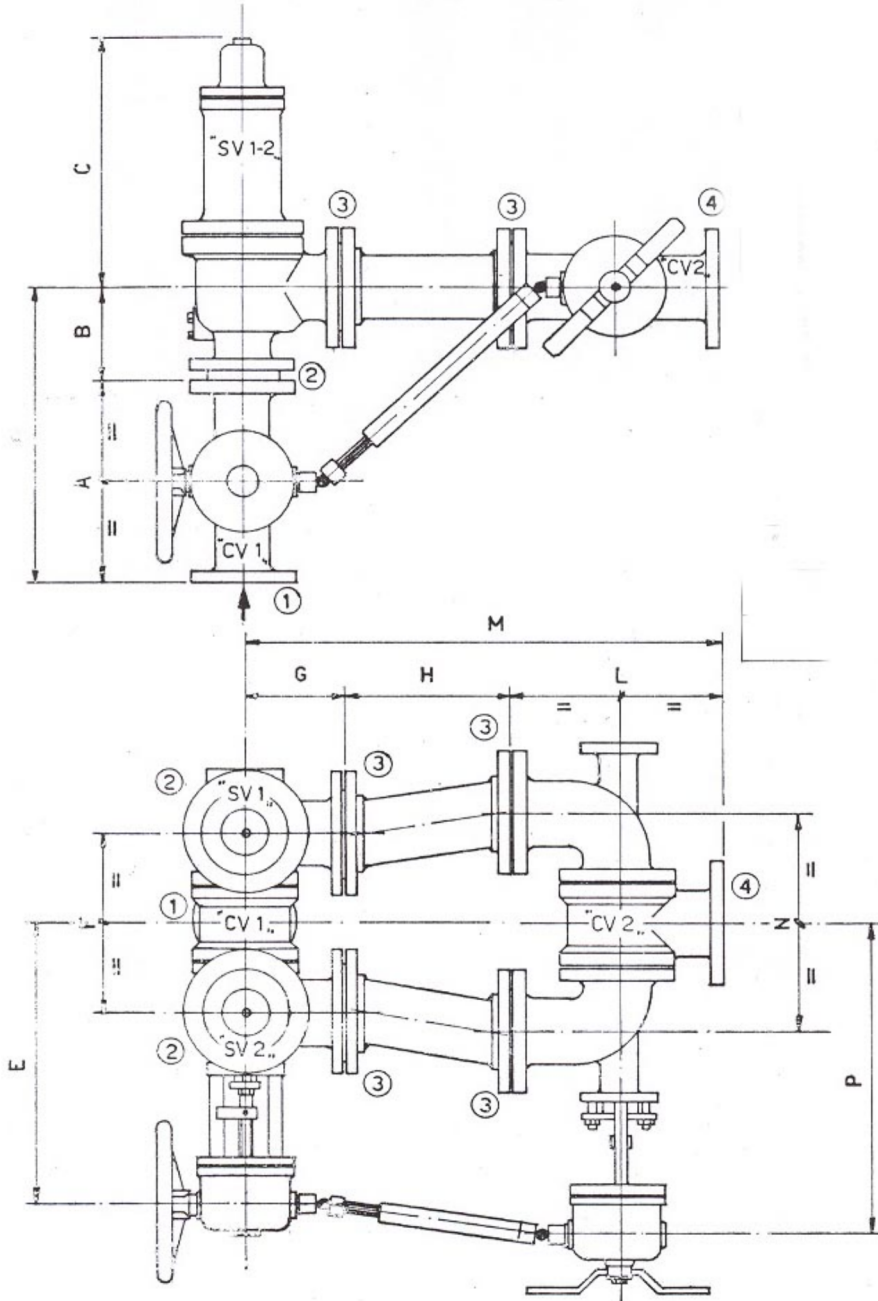



Table 4 - Overall dimensions Type 4100

CHANGEOVER VALVE CV1				SAFETY VALVE SV 1 – 2		CHANGEOVER VALVE CV 2				DIMENSIONS					
CV 1 INLET		CV 1 OUTLETS SV 1-2 INLETS		ORIFICE SV 1- 2	SV 1-2 OUTLETS CV INLETS		CV 2 OUTLET		A	B	C	D	E	F	G
DIAM Inches	RATING ANSI	DIAM Inches	RATING ANSI		DIAM Inches	RATING ANSI	DIAM Inches	RATING ANSI							
1"	150 300 600	3/4"	150 300 600	D	1"	150	1"	150	250	100	275	350	375	220	100
1"	150 300 600	1"	150 300 600	D-E	1"1/2	150	1"1/2	150	250	100	275	350	375	220	100
1"1/2	150 300 600	1"	150 300 600	D-E	2"	150	2"	150	250	105	260	355	375	230	110
1"1/2	150 300 600	1"1/2	150 300 600	F-G	2"1/2	150	3"	150	250	125	320	375	395	250	120
1"1/2	150 300 600	1"1/2	150 300 600	H	3"	150	3"	150	250	135	365	385	395	250	140
2"	150 300 600	2"	150 300 600	H-J	3"	150	3"	150	300	135	365	435	425	270	140
3"	150 300 600	2"1/2	150 300 600	J	4"	150	4"	150	370	170	450	540	515	330	170
3"	150 300 600	3"	150 300 600	K-L	4"	150	4"	150	370	170	450	540	515	330	170
4"	150 300 600	4"	150 300 600	L-M-N-P	6"	150	6"	150	380	195	585	575	565	400	210
6"	150 300 600	6"	150 300 600	Q-R	8"	150	8"	150	430	240	710	670	775	520	250
6"	300 600	6"	300 600	R	10"	150	10"	150	430	280	920	710	775	520	280
8"	150 300	8"	150 300	T	10"	150	10"	150	500	280	920	780	855	640	280



CHANGEOVER VALVES TYPE 4300

- MECHANICAL CHARACTERISTICS
- MATERIAL SELECTION
- DIMENSIONS

The CHANGEOVER valves type 4300 differ from type 4000 in the safety valve coupling seat which, instead of being “flanged“, is “threaded“, and in the geometry of the disc, which is a gasket sealing one (soft seal).

Figure 8 – Valve Type 4300

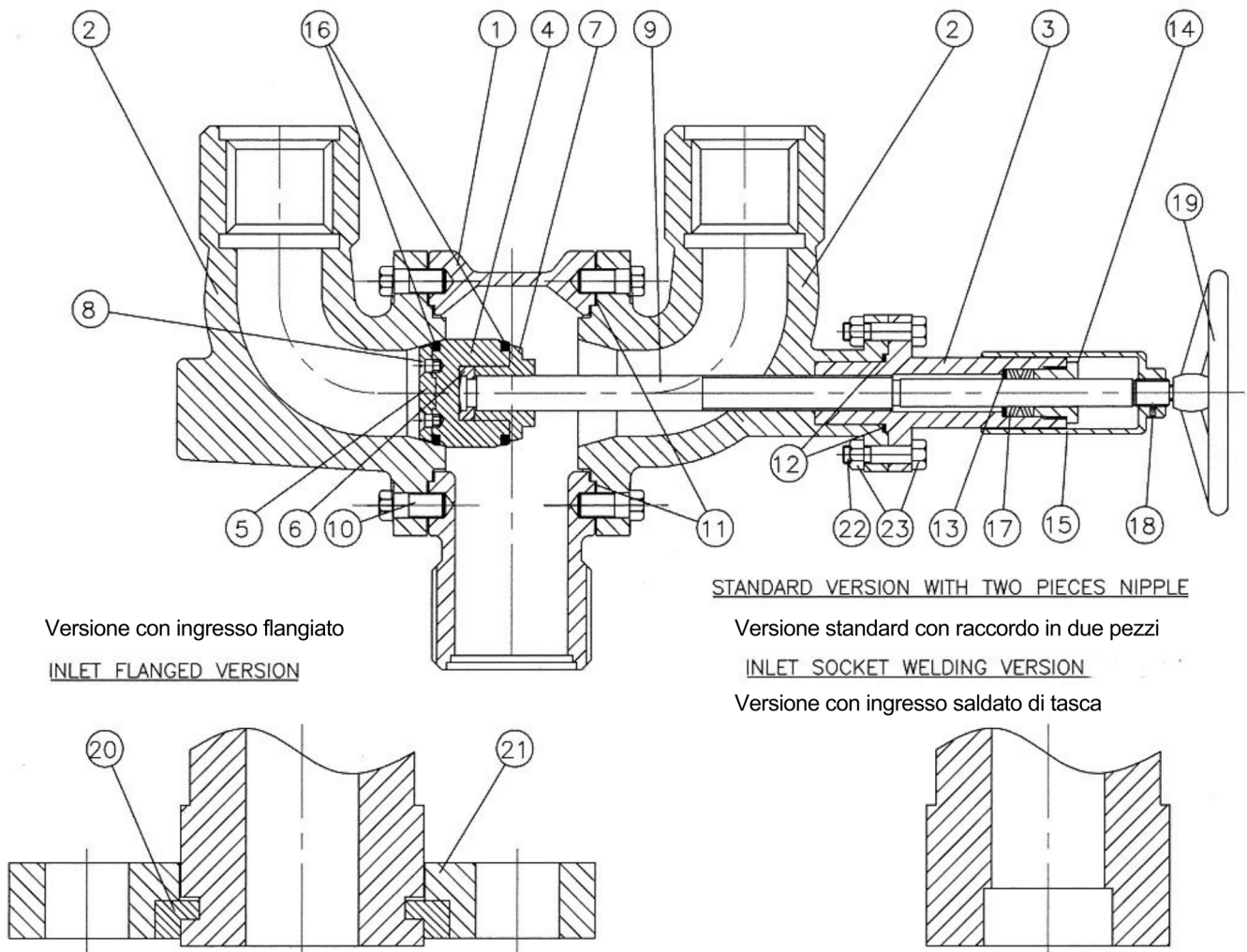



Table 5 – MATERIAL SELECTION

POS.	PARTS	4300 - BN	4300 - SN
1	BODY	BRONZE AL. UNI 1982	ASTM A351 CF8
2	BENDS		
3	BONNET	BRASS UNI 12164/5 – UNI 5705	ASTM A479 TP 304
4	DISC	ASTM A479 TP 304	
5	DISC WASHER		
6	RING (FORMED OF TWO HALF-RINGS)	BRASS UNI 12164/5 – UNI 5705	
7	DISC FITTING	ASTM A479 TP 304	
8	SCREWS		
9	ROD		
10	SCREWS		
11	BODY GASKET	K.SIL.C-4400	
12	BONNET GASKET		
13	BOTTOM RING	BRASS UNI 12164/5 – UNI 5705	
14	PACKING NIPPLE		
15	INDEX		
16	DISC GASKET	PTFE	
17	PACKING NIPPLE GASKET		
18	NUT SCREW	ASTM A479 TP 304	
19	HANDWHEEL	BRASS UNI 12164/5 – UNI 5705	
20	SPRING (formed of two half-rings)	ASTM A479 TP 304	
21	COUPLING FLANGE		
22	TIE RODS	ASTM A193 B8	
23	NUTS	ASTM A194 GR8	

Dimensions and weights

The dimensions and weights indicated below are approximate.

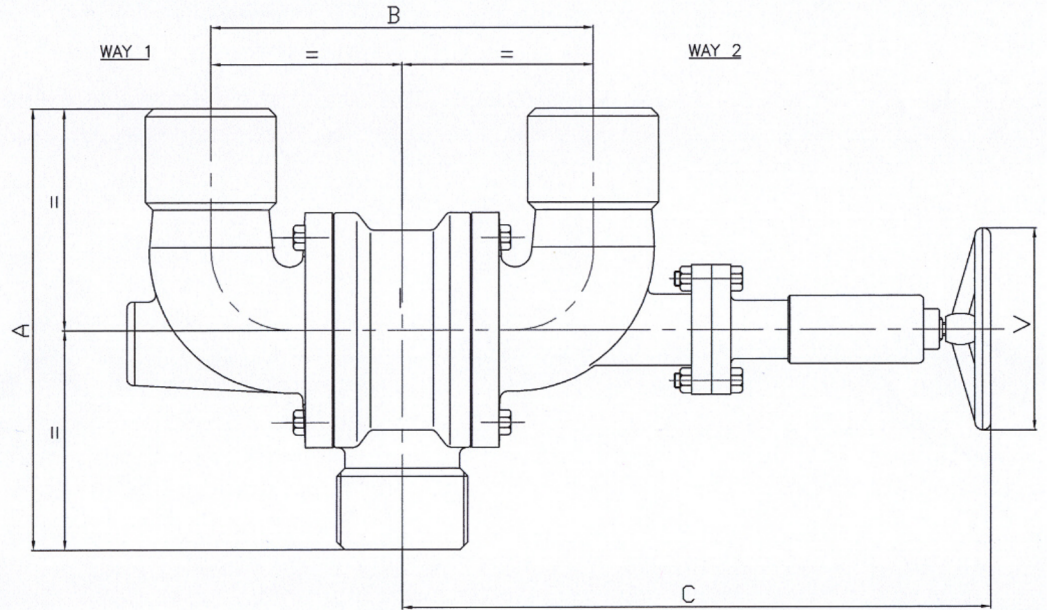

Table 6

INLET/OUTLET CONNECTIONS		TROUGH AREAS		OVERALL DIMENSIONS				APPROX. WEIGHT
		Way 1	Way 2	A	B	C	V	
ANSI Inches	ANSI Inches	cm ²	cm ²	mm	mm	mm	mm	Kg
1" 1/2	3/4"	6.1	5.8	150	160	220	90	8
1" 1/2	1"	6.1	5.8	150	160	220	90	8.5
2" 1/4	1" 1/8	14.0	14.0	190	200	330	150	14
2" 1/4	1" 1/4	14.0	14.0	190	200	330	150	14
2" 3/4	1" 1/2	20.3	20.3	230	260	350	150	21
2" 3/4	2"	20.3	20.3	230	260	350	150	21



Table 5 – CV Values

DN	CV	CVM	KW
3/4" x 3/4" x 3/4"	8.3	7	2.6
1" x 1" x 1"	14.5	12.3	4.5
1 1/2" x 1 1/2" x 1 1/2"	33.5	28.3	10.6
2" x 2" x 2"	58.5	49.5	18.5
2 1/2" x 2 1/2" x 2 1/2"	94	79.5	30
3" x 3" x 3"	134	113.5	42.5
4" x 4" x 4"	238	201.5	75
6" x 6" x 6"	535	453	169
8" x 8" x 8"	923	781	292
10" x 10" x 10"	1435	1214	454
12" x 12" x 12"	2106	1782	666
14" x 14" x 14"	2867	2426	907
16" x 16" x 16"	3737	3162	1182