



CONTROLS SUPPLY CHAIN

VALVES ACTUATORS INSTRUMENTATIONS



the **specialist** in the **efficient,**
sustainable and **safe**
distribution of **gasses**

high pressure regulators R200 series



general

R200 and R286

R200

The R200 series pilot-operated pressure reducing regulator is designed for natural gas transmission/distribution systems and industrial/commercial applications. The R200 provides smooth, quiet operation, tight shut-off and long life. It's internally actuated metal-plug eliminates disadvantages associated with boot-style regulators. The specially designed valve seat is protected from possible erosion caused by gas-flow contaminants. The R200 pressure reducing regulator can be converted into a high-pressure relief valve or backpressure regulator by simply changing the pilot. An optional inlet-strainer prevents large particles from entering the main valve. A pilot supply filter can also be added to keep pipeline debris from entering the pilot.

R286

The R286 is a R200 regulator equipped with a slam shut device, the HSV086. The HSV086 series consists of a number of effective safety shutoff valves for use in gas transmission systems, gas distribution networks and industrial gas pressure regulating systems. The HSV086 has proven its reliability for decades. The HSV086 can provide either overpressure or combined over- and underpressure protection by completely shutting off the flow of gas to the downstream system.



features

>> Tight shutoff

The type R200 uses a metal plug, eliminating the disadvantages of common boot style regulators. The proven design of the valve seat provides long life due the erosion-free protection of the seat seal. The R200 features bubble-tight shut off, even at low temperatures.

>> Quiet operation

Using patented techniques and a noise-reduction cage the R200 can reduce noise production to an acceptable minimum. Noise reduction of up to 40dB(A) is possible depending on the user's environment. Noise reduction is achieved by both multiple stage and multiple flow path techniques resulting in an exceptionally quiet regulator.

>> Low maintenance costs

The unique design of the R200 with its actuated valve plug eliminates the common problems with booth or diaphragm wear and tear. This in combination with a flow path which allows flow through the regulator without seat impingement assures long maintenance intervals.

>> O-ring design

The type R200 uses elastomer O-rings instead of gas-kets, reducing maintenance and assembly time.

>> Easy maintenance

Top entry design reduces maintenance time. Internal parts can be inspected, cleaned and replaced without removing the valve body from the pipeline.

>> Accurate control

Multiple outlet pressure ranges and narrow proportional bands offered by various the pilots available for the R200, provide stable and accurate control.

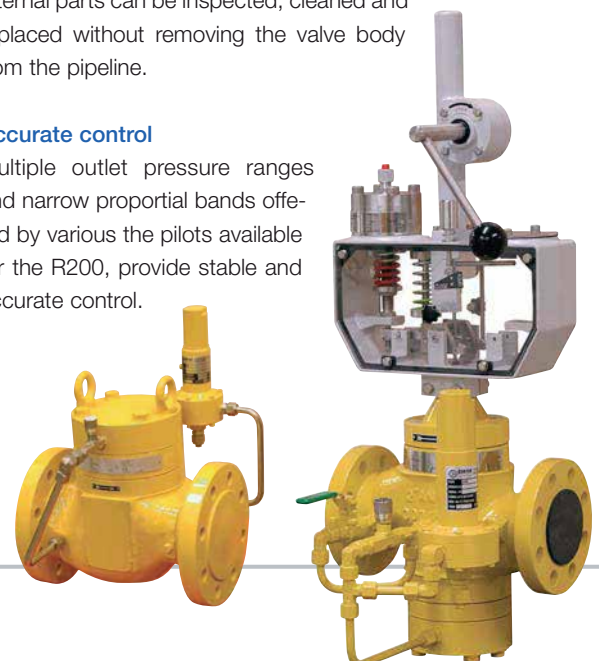



operation R200

As long as the outlet pressure is above the pilot outlet pressure setting, the pilot plug remains closed. Seat load from the main spring and the inlet pressure bleeding through the restrictor provide a downward pressure to keep the valve tightly shut off.

When the outlet pressure decreases below the pilot outlet pressure sensing, the pilot plug opens. Loading pressure bleeds downstream through the pilot faster than it can be replaced through the restrictor. This reduces loading pressure on top of the valve plug and lets inlet pressure unbalance open the valve plug.

As outlet pressure rises toward the pressure setting, it presses the pilot diaphragm against the pilot control spring and lets the

pilot valve spring shut the pilot valve plug. Then loading pressure again builds up to close the plug.

The R200 can also be used as a pilot operated pressure relief valve or back-pressure regulator.

In backpressure mode the sense of the pilot is connected upstream with the pilot seat in reserved position. If the upstream pressure exceeds the spring setting, then the pilot opens and relieves both inflow and seat load of the main line valve. This opens the plug until upstream pressure drops below pilot pressure spring setting (pilot valve closes and seat load builds up to close the plug).

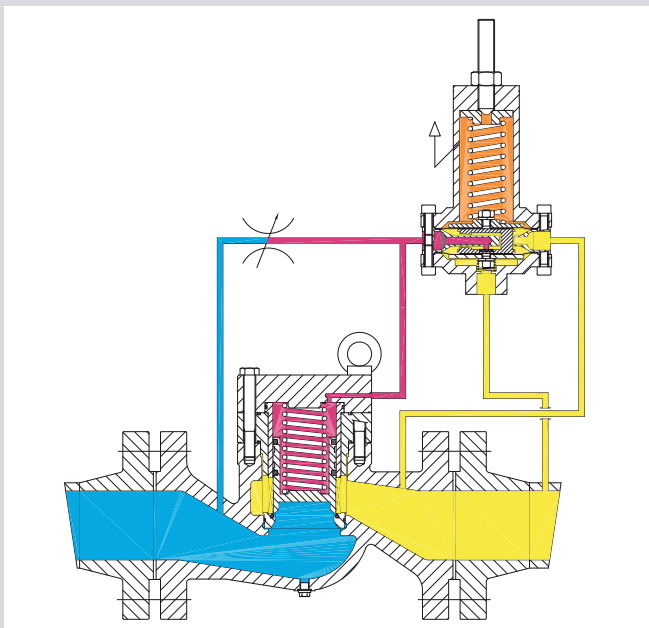

Pressure reducing regulator

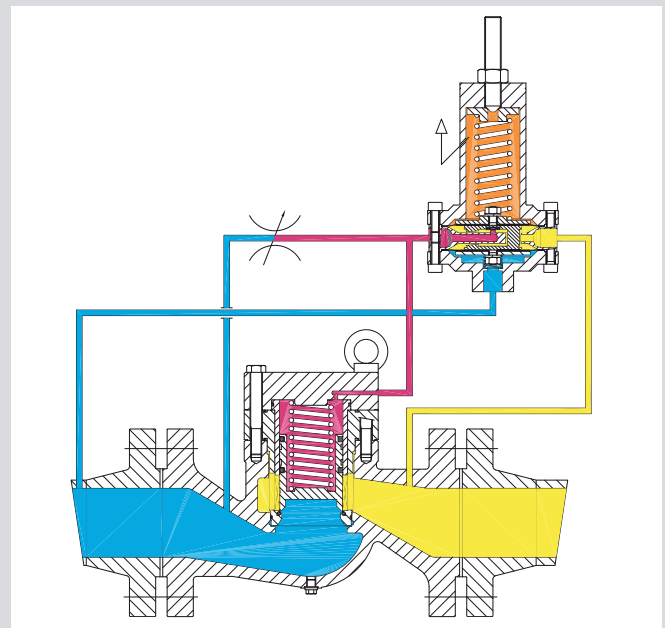

Back pressure regulator

operation R286

The R286 is a R200 regulator equipped with a slam shut device, the HSV086.

The HSV086 safeguards against exceeding a maximum pressure and falling beneath a minimum pressure. The protection against under pressure also serves as a protection against a diaphragm rupture. When the downstream pressure in the sensing element exceeds the or drops below the set trip value, the slam shut valve will close completely. In closed position, the pressure behind the closing member will be reduced to the out-

let pressure the resulting pressure difference between inlet and outlet pressure provides an additional closing force to the closing member. Tight shut off is provided by the encapsulated seal ring which closes on the seat ring. The slam shut valve can be reset manually after equalisation across the closing member.

Pressure equalization facilitated with an integral bypass valve. Maximum and minimum set points are separately adjustable and a wide range of sensing elements and adjusting springs are available.

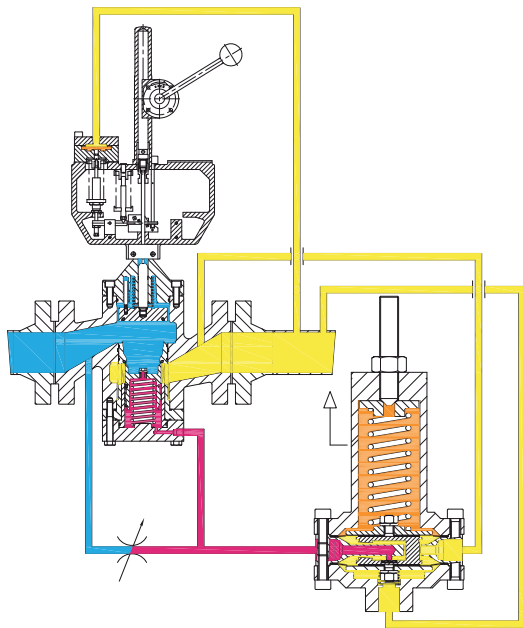

Operation R286



technical specifications

General	
Type	R200 Series
Pressure class	ANSI 150, ANSI 300 and ANSI 600
Inlet pressure range	3 to 19 bar ANSI 150, 3 to 50 bar ANSI 300, 100 bar ANSI 600
Outlet pressure range	0,5-19 bar ANSI 150, 0,5-50 bar ANSI 300, 0,5-60 bar ANSI 600*
Operating temperature range	-20°C to + 60°C
Ambient temperature range	-30°C to + 60°C

* Actual range depending on pilot.

Flow coefficient					
Nominal size		Cg value			
Inches	mm	R200/R200M	R200S/R200(S)-M	R286/R286M	R286S/R286(S)-M
2"	50	2000	1210	1860	1125
3"	80	4000	2800	3720	2600
4"	100	6760	4970	6280	4620
6"	150	14400	10100	13400	9390

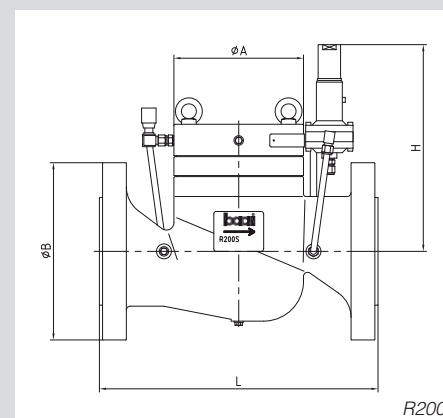
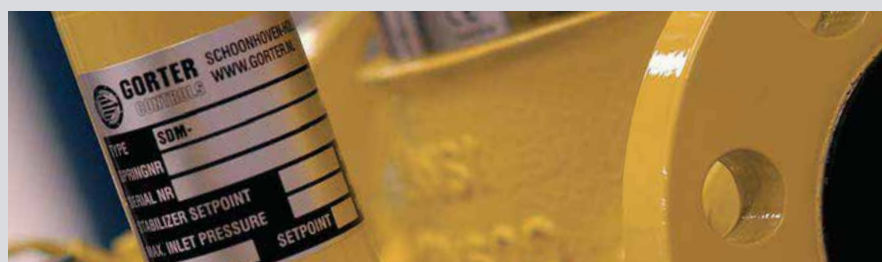

R200

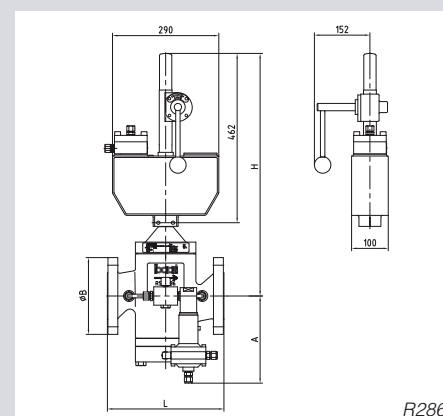

R286

Dimensions (mm) and weights (kgf) of the R200												
Nominal size		ANSI150/300/600		ANSI 150			ANSI 300			ANSI 600		
Inches	mm	øA	H	øB	L	Weight	øB	L	Weight	øB	L	Weight
2"	50	130	290	152	267	30	165	267	35	165	292	41
3"	80	165	325	191	318	52	210	318	57	210	356	63
4"	100	195	350	229	356	78	254	356	86	274	432	106
6"	150	260	415	279	445	157	318	445	157	356	559	207

Dimensions (mm) and weights (kgf) of the R286												
Nominal size		ANSI150/300/600		ANSI 150			ANSI 300			ANSI 600		
Inches	mm	A	H	øB	L	Weight	øB	L	Weight	øB	L	Weight
2"	50	212	627	152	292	55	165	292	60	165	292	65
3"	80	238	662	191	356	85	210	356	90	210	356	95
4"	100	270	677	229	432	147	254	432	155	274	432	165
6"	150	336	737	279	559	282	318	559	290	356	559	310

Materials specifications (Standard)			
Regulator part	Material	Slam shut part	Material
Body	A352-LCC(QT) or equal	Sensing element	S355 or equal
Bonnet Flange	S355 or A352-LCC(QT)	Diaphragm sensing element	NBR with nylon reinforcement
Plug	SS	Control mechanism internals	SS
Guiding bush	SS	Valve plug	S355 or equal
Pilot body	S355 or equal	Valve stem	SS
Silencer	Metal foam (CrNi)	Seat ring	SS
Dynamic O-rings	Viton	Dynamic O-rings	Viton
Static O-rings	NBR	Static O-rings	NBR