

Gas Pressure Regulator RMG 361



PRODUCT INFORMATION

**Serving the Gas Industry
Worldwide**

Gas Pressure Regulator RMG 361

Application, characteristics, technical data

Application

- Gas pressure regulators (GDR) for commercial and industrial gas installations as well as local supply installations
- can be used for natural gas and all non-corrosive gases

Characteristics

- GDR with integrated SAV safety shut-off valve and optional SBV safety relief valve for gas leakages
- max. valve diameter= nominal size = DN
- SAV safety shut-off valve with axial flow; pressure compensation valve (internal by pass) integrated in shut-off valve

TECHNICAL DATA				
max. allowable pressure PS	10 bar			
setting range	spring no./colour		W _a in bar	
		* RE 0	* RE 1 / RE2	* RE 3
	0 / blue		0,020 ... 0,030	
	1 / grey		0,025 ... 0,050	0,020 ... 0,030
	2 / yellow		0,045 ... 0,100	0,020 ... 0,050
	3 / brown		0,090 ... 0,200	0,045 ... 0,100
	4 / bright red		0,150 ... 0,300	0,075 ... 0,150
	5 / dark red		0,250 ... 0,400	0,125 ... 0,200
	6 / light blue		0,350 ... 0,500	0,175 ... 0,250
	7 / white	1,0 ... 2,5	0,450 ... 0,600	
8 / green	2,0 ... 4,0	0,550 ... 0,800		
9 / black		0,650 ... 1,000		
	* RE = regulating assembly		< 0,020 bar - special feature at option	
accuracy class AC and lock-up pressure class SG	p _a -range in bar	AC	SG **	
	0,020 ... 0,030	10	30/50	
	> 0,030 ... 0,100	10	20/30	
	> 0,100 ... 0,500	5	10/20	
	> 0,500 ... 1,000	2,5	10	
> 1,000 ... 4,000	≥ 5	≥ 10		
pipe sizes connection	DN 25, DN 50, DN 80, DN 100:		DIN flanges PN 16	
	DN 50, DN 80:		ANSI 150	
materials	main valve body and SAV		ductile iron	
	actuator diaphragm		steel, aluminium alloy	
	diaphragms, sealings		rubber	
	internal parts		aluminium alloy, steel, brass	
temperature range, class 2	-20°C to +60°C			
function and strength	acc. to DIN EN 334 and DIN EN 14382			
DIN-DVGW registration no.	NG-430 1 AS 0094			

Gas Pressure Regulator RMG 361

Application, characteristics, technical data

3

DEVICE SIZES							
DN	valve seat diameter [mm]	KG value in m ³ /h (for natural gas, ρ _n =0,83 kg/m ³)		max inlet pressure p _{Umax} (bar)* regulating assembly RE			
		without noise reduction	with noise reduction	RE 0	RE 1	RE 2	RE 3
DN 25	25	370	approximately 10 % loss of capacity	10	10		
	31	460		10	10		
DN 50	31	800		10	10	10	
	50	1400		10	6 (10)	10	
DN 80	60	2200		10		10	5
	80	2700		10		6 (10)	5
DN 100	60	2900		10		10	5
	80	3700		10		6 (10)	5
	100	4200		10		4 (8)	5

*) The limitation of the inlet pressure range Δp_{Umax} for a diaphragm assembly RE 1 and RE 2 is not given for reasons of material strength but in the interest of maintaining the regulating accuracy. The inlet pressure deviations though may not exceed the limit of the valve's nominal pressure rating. The accuracy classes AC and lock-up pressure classes SG are fixed by the DVGW type tests. The maximum value that is within the allowed exceeding limits is the value indicated in brackets.

ADJUSTING RANGES OF SAV SAFETY SHUT-OFF VALVE RMG 673, K 1 AND K2 A								
control device	setpoint spring			upper response pressure *		lower response pressure *		response pressure group
	No.	colour	wire-dia. in mm	adjustable range W ₉₀ (bar)	smallest difference between response pressure and normal operating pressure Δ p (bar)	adjustable range W _{9U} (bar)	smallest difference between response pressure and normal operating pressure Δ p (bar)	
K1a	1	yellow	2,50	0,050 ... 0,100	0,030			10 / 5,0
	2	bright red	3,20	0,080 ... 0,250	0,050			10 / 5,0
	3	dark red	3,60	0,200 ... 0,500	0,100			5 / 2,5
	4	white	4,75	0,500 ... 1,500	0,250			5 / 2,5
	5	yellow	1,00			0,010 ... 0,015	0,012	15
	6	white	1,20			0,014 ... 0,040	0,030	15 / 5,0
	7	black	1,40			0,035 ... 0,120	0,060	5
K2a	2	bright red	3,20	0,400 ... 0,800	0,100			10 / 5,0
	3	dark red	3,60	0,600 ... 1,600	0,200			10 / 5,0
	4	white	4,75	1,500 ... 5,000	0,300			5 / 2,5
	5	light blue	1,10			0,060 ... 0,150	0,050	15 / 5,0
	6	black	1,40			0,120 ... 0,400	0,100	5

*) Note: If the control device is set for both the upper and lower response pressure value, the difference between the setpoints of the upper and lower response pressure (p_{SO} and p_{SU}) must be at least 10 % greater than the sum of the values specified for Δp_O and Δp_U.

$$p_{SO} - p_{SU} \geq 1.1 (\Delta p_O + \Delta p_U)$$

**) The higher AG group is for the first half, the lower AG group is for the second half of the setting range.

SAFETY RELIEF VALVE (SBV FOR GAS LEAKAGES)			
No.	setpoint spring		regulating assembly
	wire-dia. in mm		
1	3,5		RE 1
1	3,5		RE 2
2	3,6		
3	4,5		
2	3,6		RE 3
3	4,5		

*** optional fixed set

Gas Pressure Regulator RMG 361

Application, characteristics, technical data / Design and operation

SAFETY RELIEF VALVE (SBV FOR GAS LEAKAGES)				
No.	setpoint spring		regulating assembly	actuating pressure *** adjusting via p_{AS} (mbar)
		wire diameter in mm		
1		3,5	RE 1	15+5 ... 90+15
1		3,5	RE 2	15+5
2		3,6		30+15
3		4,5		60+15
2		3,6	RE 3	15+10
3		4,5		30+10

*** optional fixed setpoint value

Versions (at option)

- with leakage SBV for regulating assembly 1, 2, 3 (pa up to 0.5 bar)
- with SAV manual release
- with SAV electro-magnetic remote release
- with electric position indicator SAV "closed" by an inductive proximity switch
- regulating assembly 1 + 2 with safety diaphragm
- with respirator valve Type RMG 915 (SAV/RE)
- with noise reduction
- without SAV

Design and Operation (figure 1)

The RMG 361 gas pressure regulator is designed to keep the outlet pressure constant, irrespective of changes in the inlet pressure and volumetric flowrate of the regulating line. It consists of the regulating device (1), valve (2), SAV safety shut-off valve (3), switching device (4), control device (5) and valve housing (6).

The valve of the regulating device is pressure compensated by means of a compensation diaphragm (7). Different valve sizes can be used for each nominal width. An optional SBV safety relief valve (9) can be fitted in the regulating device.

The outlet pressure is fed via the measuring line to the measuring unit. This compares the actual value with the setpoint specified by the force applied by the setpoint spring (10). Any deviation from the setpoint will cause an adjustment in the valve (2) via the valve stem (11) so that the actual value is adjusted to the setpoint. The valve closes tight if there is zero consumption.

Types with a safety diaphragm (13) have this positioned over the diaphragm (8). If this diaphragm (8) breaks, the safety diaphragm (13) presses against the diaphragm cover and prevents gas leaking into the atmosphere.

A foam metal cylinder (12) can be used in the actuator in order to reduce noise.

The safety shut-off valve arranged on the inlet side shuts off the gas flow if the outlet pressure deviates above or below the specified limit values. In this case the measuring diaphragm (20) of the control device (5) is moved in such way that the balls (21) of the latch mechanism release the actuator stem (22). The spring force causes this to strike the release socket of the switching device (4), as a result of which the shaft (23) of the SAV shut-off valve (3) disengages and causes the SAV shut-off valve to close. The SAV shut-off valve can only be opened manually. For this the outlet pressure at the measuring point must be reduced below the upper response pressure or increased above the lower response pressure by at least the value of the re-engagement differential (Δp).

Mounting, operation and maintenance

For mounting and maintenance the DVGW worksheets G 490, G 491, G 495 and G 600 have to be considered as well as the general operating instructions.

The "General Operating Instructions, Spare Parts 361.20.01" gives full information about mounting, operation, maintenance and important spare parts.

The gas pressure regulator should preferably be mounted in a horizontal position in the pipework.

Gas Pressure Regulator RMG 361

Design and operation

with safety diaphragm

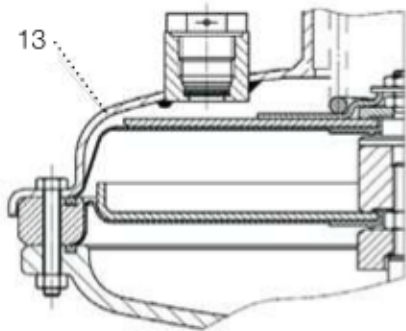

without safety diaphragm

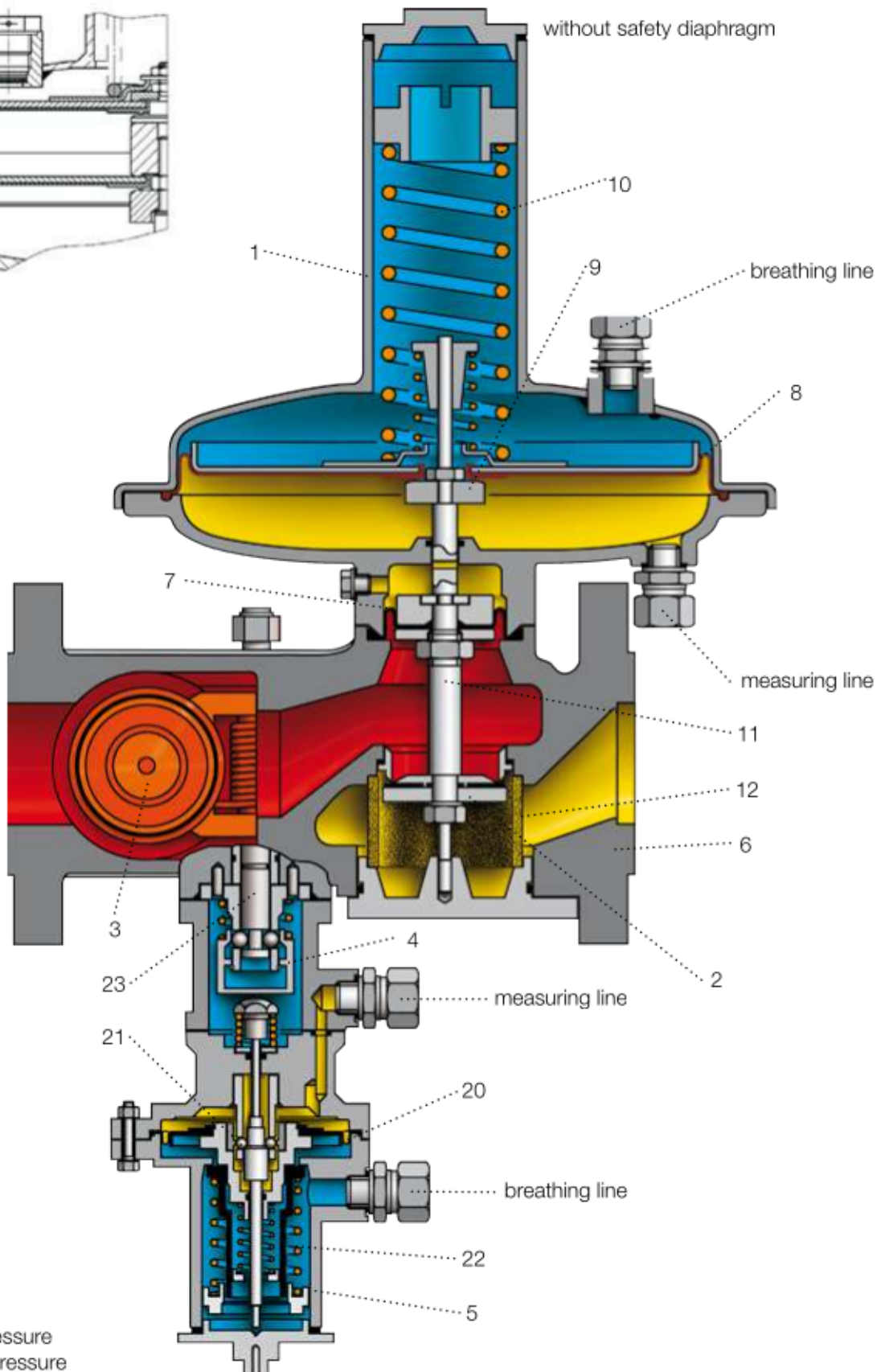

- inlet pressure
- outlet pressure
- atmosphere

5

Gas Pressure Regulator RMG 361

Dimensions, weights, connections

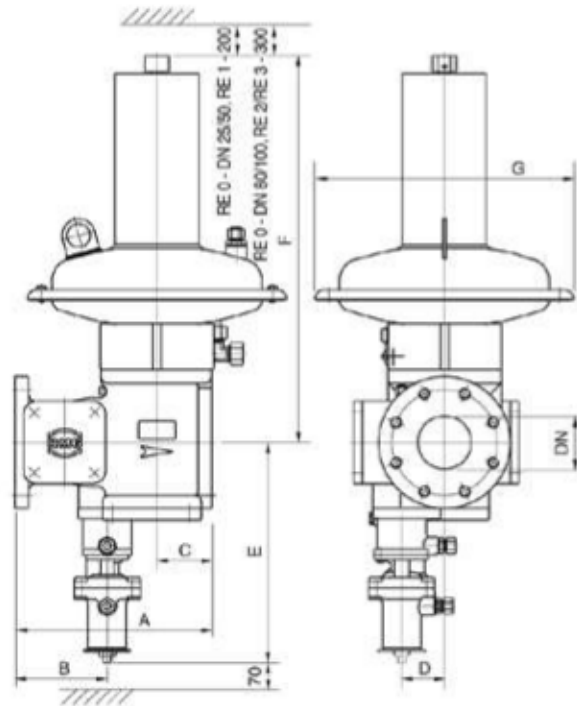

DIMENSIONS																	
DN	A	B	C	D	E	F				G				weight			
						regulating assembly				regulating assembly				regulating assembly			
						RE0	RE1	RE2	RE3	RE0	RE1	RE2	RE3	RE0	RE1	RE2	RE3
						(mm)								(kg)			
25	184	80	52	40	280	355	365	---	---	195	296	---	---	27	20	---	---
50	254*	114	75	50		360	370	510	---	---	---	---	---	33	26	41	---
80	298	140	83	65	330	570	---	595	590	225	---	394	525	65	---	60	90
100	352	160	100	72										75	---	70	100

*) face to face dimension 250 mm at option

CONNECTIONS OF MEASURING LINES AND VENT LINES			
	actuator		SAV-Kontrollgerät
	measuring line	vent line	measuring line and vent line
RE 0	connection** for:	connection** for:	pipe 12 x 1,5 (thread M16 x 1,5)
DN 25/50	pipe 12 x 1,5 (thread M16 x 1,5)	pipe 12 x 1,5	
DN 80/100	pipe 16 x 2 (thread M22 x 1,5)	(thread M16 x 1,5)	
RE 1	pipe 12 x 1,5 (thread M16 x 1,5)		
RE 2			
DN 25/50	pipe 12 x 1,5 (thread M12 x 2)	pipe 12 x 1,5 (thread R 1/2")	
DN 80/100	pipe 16 x 2 (thread 16 x 2)		
RE 3	pipe 16 x 2 (thread M22 x 1,5)		

** screw connection without brazing with compression joint according to DIN 2353

connecting elements: DN 25: screw bolt M 12 x 50 DIN 2509-5.6; nut M12 DIN 934-5
 DN 50 bis 100: screw bolt M16 x 60 DIN 2509-5.6; nut M16 DIN 934-5

Gas Pressure Regulator RMG 361

Type description

example:

RMG 361 - 50 - K1a / E1 / HA / F - 31 / 1L / 3 - So

SIZE								type	size DN	SSV control device	electromagnetic remote actuation	manual release	electrical remote transmission of valve position	valve seat diameter	regulator device	setpoint spring	special version (to be specified in detail)	
DN 25																		25
DN 50																		50
DN 80																		80
DN 100																		100
SSV CONTROL DEVICE																		
		setting range in bar																
		W _{ho}	W _{hu}															
K1a	0,05 ... 1,50	0,01 ... 0,12					K1a											
K2a	0,04 ... 5,00	0,06 ... 0,40					K2a											
ELECTR. MAGNET. REMOTE ACTUATION																		
electromagnetic remote actuation		actuation with energization				E1 / E2												
MANUAL RELEASE																		
manual actuation with push button valve RMG 912						HA												
REMOTE TRANSMISSION																		
electrical remote transmission of valve position "closed"						F												
REGULATOR DEVICE																		
DN	diaphragm assembly	valve	SBV blocked	with SBV	with safety diaphragm	valve seat-dia.												
25	RE 0	25 31	--	--	--	25 31	0											
	RE 1	25 31	1	1L	1S	25 31	1...											
50	RE 0	31 50	--	--	--	31 50	0											
	RE 1	31 50	1	1L	1S	31 50	1...											
	RE 2	31 50	2	2L	2S	31 50	2...											
80	RE 0	60 80	--	--	--	60 80	0											
	RE 2	60 80	2	2L	2S	60 80	2...											
	RE 3	60 80	3	3L	--	60 80	3...											
100	RE 0	60 80 100	--	--	--	60 80 100	0											
	RE 2	60 80 100	2	2L	2S	60 80 100	2...											
	RE 3	60 80 100	3	3L	--	60 80 100	3...											
SETPOINT SPRING																		
setpoint spring		adjustment range in bar																
No.	colour	RE 0	RE 1/RE 2	RE 3														
0	black/blue		0,020 ... 0,030			0												
1	grey		0,025 ... 0,050	0,020 ... 0,030		1												
2	yellow		0,045 ... 0,100	0,020 ... 0,050		2												
3	brown		0,090 ... 0,200	0,045 ... 0,100		3												
4	bright red		0,150 ... 0,300	0,075 ... 0,100		4												
5	dark red		0,250 ... 0,400	0,075 ... 0,150		5												
6	light blue		0,350 ... 0,500	0,125 ... 0,200		6												
7	white	1,0 ... 2,5	0,450 ... 0,600	0,175 ... 0,250		7												
8	green	2,0 ... 4,0	0,550 ... 0,800			8												
9	black		0,650 ... 1,000			9												

