

SERVING THE GAS INDUSTRY WORLDWIDE

Gas Pressure Regulator HON 680

Product Information

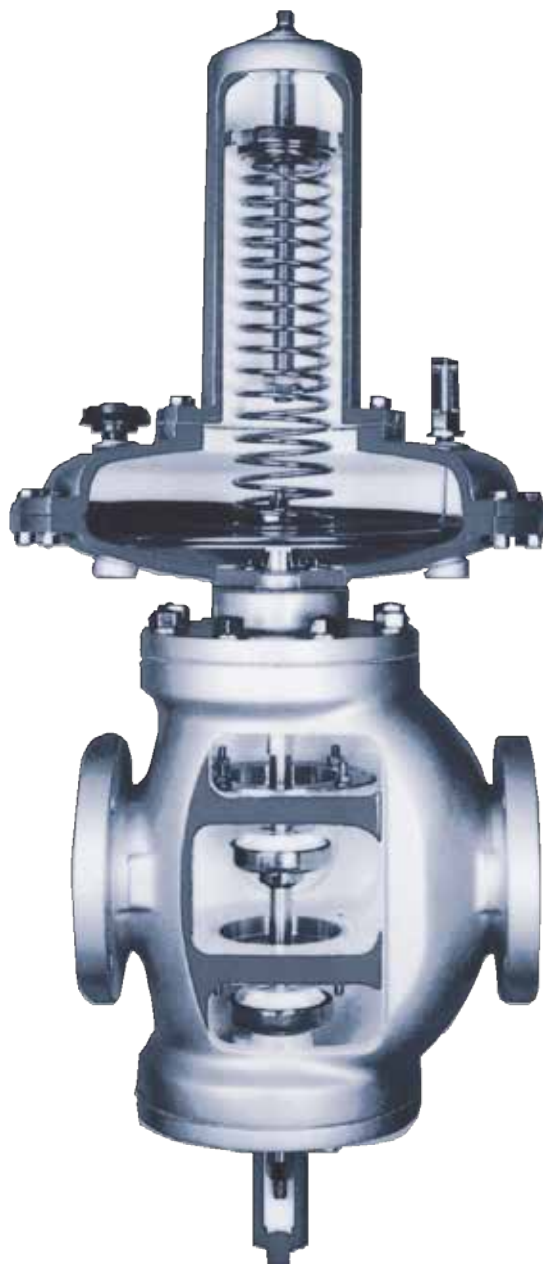

CONTROLS SUPPLY CHAIN[®]
VALVES ACTUATORS INSTRUMENTATIONS

www.controlssupplychain.com | info@controlssupplychain.com

INTRODUCTION, APPLICATION, FEATURES, TECHNICAL DATA

Introduction

- The HON 680 is a comprehensive range of double beat balanced valve regulators.
- Use with confidence on natural and manufactured gases of non-aggressive nature, including Nitrogen, Carbon Dioxide, Propane and Butane.

Application

- The HON 680 embrace a wide span of applications, principal amongst these is district governing requiring high peak flow capacity and wide rangeability, together with industrial and commercial gas utilisation applications, either as supply regulators at the factory gate, ring main off-take regulators within the factory premises or directly as burner pressure or process gas control regulators.

- Some installations adopt the simple direct-acting models, others call for the fine control and tight lock-up qualities conferred by auxiliary control systems, in which additional features such as automatic outlet pressure change, volume flow over-ride etc., may readily be incorporated as desired.
- Whichever control form is used all models are designed to accept line gas as the actuating medium, most control systems are arranged to 'bleed-to-line', avoiding discharge to atmosphere and all units are amenable to single or multi-stage pressure reduction and monitor/active modes of installation.

Features

- Fully balanced internal double beat valves assembly
- Extremely high flow capacities
- Positive, accurate and sensitive control

- Wide operational pressure range
- Stainless steel internals
- Full or Reduced bore valves

Models Available

- HON 680 MK1, 680-EVA, 680H-EVA Regulators within this group are inherently self-acting, these are spring loaded, fall-open, rapid response models. The 680-EVA and 680H-EVA MK2 include the facility for external valve adjustment while the regulator remains on stream. An auxiliary control system is often applied to these models in a way that imparts the benefit of positive lock-up at minimal outlet pressure increment whilst still permitting the main regulator to work in self-acting form over the working flow range.

With such an arrangement shown in Diagram 1, page 10, the inlet pressure capability of certain sizes of these models can be increased.

TECHNICAL DATA

REGULATOR SELECTION GUIDE														
Maximum Inlet Pressure	Outlet Pressure Range mbar/bar (" wg/psi)	Model(s) Applicable	Mode of Operation	VALVE Position at Rest	BRANCH SIZES									
					Full Bore Valves				Reduced Bore Valves					
					3"	4"	6"	8"	2"	3"	4"	6"	8"	
2.07 bar (30 psi)	15 - 210 mbarg (6" wg - 3 psig)	680 MK1 680-EVA	Self-Acting or Auxiliary Controlled	OPEN	•	•	•	•	•	•	•	•	•	
	125 - 415 mbarg (1.8 - 6 psig)	680H MK1 680H-EVA		OPEN	•	•	•	•	•	•	•	•	•	•
4.5 bar (65 psi)	15 - 90 mbarg (6" - 38" wg)	680-EVA	Auxiliary Controlled	OPEN	•				•	•	•			
	15 - 310 mbarg (6" wg - 4.5 psig)	680H-EVA		OPEN	•				•	•	•			
7 bar (100 psi)	15 - 90 mbarg (6" - 36" wg)	680 MK1	Auxiliary Controlled	OPEN	•	•			•	•	•	•	•	

Key: EVA - External Valve Adjustment

Connections

All body sizes have flanged connections to PN16: BS EN 1092-2:1997

Installation

The regulator may be mounted in any orientation to suit site conditions, moisture or debris must not ingress

the vent valve. For optimum performance the recommended operating position is with diaphragm casing horizontal and spring housing pointing vertically upwards, e.g. regulators installed in other than the vertical position in a horizontal main

will give a reduced outlet pressure depending on gravitational forces.

It is important when installing equipment that pipeline stresses are kept to a minimum and no undue external forces are placed on the connections.

Note: On some industrial and burner applications, where rapid changes in flow rates occur, it may be necessary to fit a variable jet into the regulator impulse line to tune the regulator to the downstream system.

Temperature Range

-20°C to +60°C

SPRING SELECTION REGULATORS

HON 680 & 680H - MK1/EVA REGULATOR					
Outlet Pressure Range		Regulator size			Model
		DN 80	DN 100	DN 150 & DN 200	
Based on 5% Capacity setting		SPRING Number & Colour	SPRING Number & Colour	SPRING Number & Colour	
mbar	"wg				
15 - 20	6 - 8	378 White/Maroon	409 White/Gold	417 White/Light Blue	680 MK1 680-EVA
20 - 30	8 - 12	402 Black/Maroon	410 Black/Gold	418 Black/Light Blue	
30 - 40	12 - 16	403 Dark Green/Maroon	411 Dark Green/Gold	419 Dark Green/Light Blue	
40 - 50	16 - 20	404 Yellow/Maroon	412 Yellow/Gold	420 Yellow/Light Blue	
50 - 60	20 - 24	405 Red/Maroon	413 Red/Gold	421 Red/Light Blue	
60 - 90	24 - 36	406 Brown/Maroon	414 Brown/Gold	422 Brown/Light Blue	
90 - 140	36 - 56	407 Grey/Maroon	415 Grey/Gold	423 Grey/Light Blue	
100 - 210	40 - 84	857 Stone/Maroon	857 Stone/Maroon	856 Purple/Light Blue	
125 - 205	1.8 - 3 psi	523 Mauve/Orange	523 Mauve/Orange	520 (x2) Mauve/Light Blue	
185 - 275	2.7 - 4 psi	525 Pink/Orange	525 Pink/Orange	521 (x2) Pink/Light Blue	
255 - 350	3.7 - 5 psi	522 Stone/Orange	522 Stone/Orange	544 (x2) Stone/Light Blue	
345 - 415	5 - 6 psi	935 Blue/Orange	935 Blue/Orange	-	
330 - 415	4.8 - 6 psi	-	-	1006 (x2) Self	

DIMENSIONS & WEIGHTS

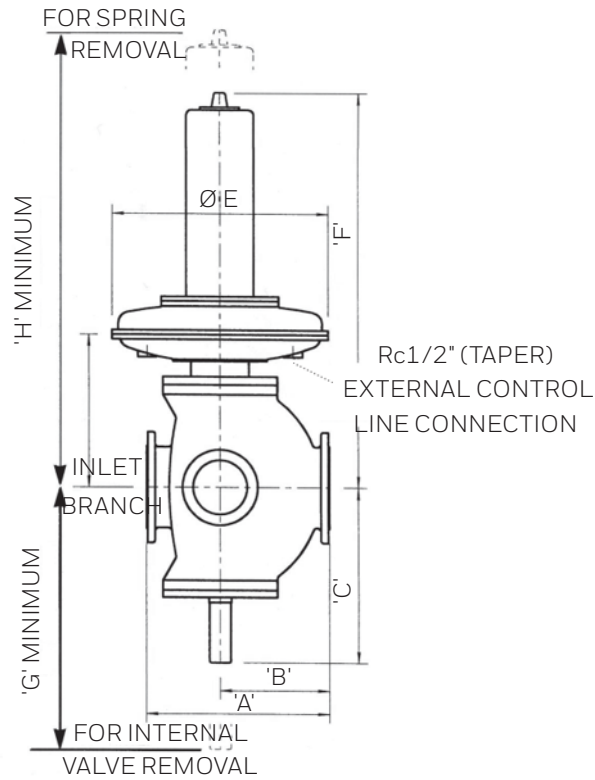

REGULATOR		DIMENSIONS IN MM								WT
Model	Size	A	B	C	D	E	F	G	H	Kgs
680 MK1	DN 80	318	178	264	250	451	702	508	864	98
680-EVA		318	178	278	250	451	702	458	864	98
680H-EVA		318	178	278	250	451	968	458	1378	111
680 MK1	DN 100	369	208	315	296	451	740	559	902	133
680-EVA		369	208	304	296	451	740	496	902	133
680H-EVA		369	208	304	296	451	1006	496	1416	151
680 MK1	DN 150	473	276	410	411	559	1020	674	1182	268
680-EVA		473	276	430	411	559	1020	674	1182	268
680H-EVA		473	276	430	411	559	1442	674	2032	305
680 MK1	DN 200	569	340	470	475	559	1080	712	1245	350
680-EVA		569	340	475	475	559	1080	712	1245	350
680H-EVA		569	340	475	475	559	1505	712	2096	388

CAPACITIES IN SCMH FOR NATURAL GAS SG: 0.6

CAPACITIES					
Inlet Pressure	Outlet Pressure	Regulator size			
	mbar/bar	DN 80	DN 100	DN 150	DN 200
69 mbar	20	1,250	4,360	5,090	8,380
	40	960	1,780	3,890	6,410
	60	550	1,030	2,250	3,710
	65	380	700	1,540	2,530
138 mbar	20	1,990	3,690	8,080	13,310
	50	1,750	3,250	7,100	11,690
	69	1,570	2,910	6,360	10,470
	103	1,100	2,040	4,450	7,330
	131	490	910	1,990	3,270
207 mbar	20	2,420	4,480	9,800	16,140
	69	2,140	3,970	8,690	14,310
	103	1,890	3,510	7,680	12,650
	138	1,610	2,980	6,520	10,730
	200	510	940	2,070	3,400
345 mbar	20	3,190	5,910	12,900	21,290
	69	2,990	5,550	12,100	19,980
	138	2,660	4,940	10,800	17,800
	207	2,230	4,140	9,000	14,920
	276	1,660	3,080	6,700	11,080
	338	540	990	2,200	3,570
483 mbar	20	3,790	7,020	15,400	25,300
	138	3,490	6,470	14,100	23,300
	276	2,870	5,330	11,700	19,200
	414	1,750	3,250	7,100	11,700
	448	1,240	2,300	5,000	8,300
690 mbar	69	4,470	8,280	18,100	29,800
	207	4,220	7,820	17,100	28,200
	345	3,790	7,020	15,400	25,300
	483	3,080	5,720	12,500	20,600
	621	1,890	3,510	7,700	12,700
	655	1,330	2,470	5,400	8,900
1.03 bar	69*	5,520	10,200	22,400	36,900
	207	5,420	10,000	22,000	36,200
	345	5,290	9,800	21,500	35,300
	690	4,110	7,600	16,700	27,500
	966	1,960	3,600	7,900	13,100
	1.0	1,450	2,700	5,900	9,700
1.38 bar	241*	6,400	11,900	26,000	42,800
	345	6,270	11,600	25,400	41,900
	690	5,940	11,000	24,100	39,700
	1.03 bar	4,570	8,500	18,500	30,500
	1.31 bar	2,090	3,900	8,500	14,000
2.07 bar	621*	8,230	15,300	33,400	55,000
	1.03 bar	7,970	14,800	32,400	53,400
	1.38 bar	6,990	13,000	28,300	46,700
	1.72 bar	5,350	9,900	21,700	35,800
	2.0 bar	2,350	4,400	9,500	15,700

Types of Gases: The capacities shown in the tables are given in terms of natural gas SG 0.6. For all other gases multiply by the following correction factor:

$$\sqrt{\frac{0.6}{\text{SG of gas handled}}}$$

CAPACITIES IN SCMH FOR NATURAL GAS SG: 0.6

CAPACITIES					
Inlet Pressure	Outlet Pressure bar	Regulator size			
		DN 80	DN 100	DN 150	DN 200
2.76 bar	0.97*	10,100	18,800	41,100	67,600
	1.38	9,900	18,300	40,000	65,900
	2.07	8,000	14,800	32,300	53,200
	2.41	6,000	11,100	24,400	40,100
3.45 bar	1.38*	11,900	22,200	48,500	79,800
	2.07	11,400	21,200	46,400	76,300
	2.76	8,900	16,500	36,000	59,300
	3.10	6,700	12,400	27,000	44,500
4.5 bar	1.72*	14,400	26,800	58,600	96,100
	2.28	14,200	26,300	57,600	95,000
	2.76	13,200	24,500	53,700	88,500
	3.45	11,200	20,800	45,600	75,200
5.17 bar	4.14	7,100	13,200	28,800	47,500
	2.28*	16,700	31,000	67,700	111,500
	2.76	16,100	29,800	65,200	107,500
	3.45	14,800	27,400	59,900	98,500
6.9 bar	4.14	12,700	23,600	51,700	85,000
	4.83	7,700	14,300	31,300	51,500
	3.17*	21,400	39,600	86,600	142,500
	3.45	21,200	39,400	86,100	142,000
8.62 bar	4.14	20,400	37,900	82,900	136,500
	4.83	19,100	35,500	77,600	128,000
	5.52	16,600	30,800	67,300	111,000
	6.21	12,300	22,800	49,800	82,000
10.34 bar	4.07*	25,900	48,100	105,000	173,000
	4.83	25,300	46,900	102,500	169,000
	5.52	24,200	44,800	98,000	161,500
	6.90	20,400	37,900	82,900	136,500
12.07 bar	8.28	9,900	18,400	40,300	66,300
	5.03*	30,600	56,700	124,000	204,000
	6.21	29,400	54,500	119,000	196,500
	6.90	28,200	52,300	114,500	188,500
16 bar	8.28	24,200	44,800	98,000	161,500
	9.66	15,000	27,900	61,000	100,000
	5.96*	35,300	65,400	143,000	235,500
	6.90	34,500	64,100	140,000	231,000
Standard Valve Diameter	8.62	31,700	58,700	128,500	211,500
	10.34	24,500	45,400	99,000	163,500
	11.72	11,200	20,800	45,500	75,000
	9*	43,700	81,000	177,300	292,300
Reduced Valve Diameter	10.34	41,700	77,400	169,400	279,200
	11.72	38,600	71,500	156,500	258,000
	13.8	30,200	56,000	122,600	202,100
	15.17	19,600	36,400	79,700	131,400
Capacity Multiplication Factor for Reduced Bore Bvalves		0.59	0.667	0.556	0.734

*The capacities give alongside outlet pressures marked * also apply to outlet pressures lower than those indicated.

The tabulated capacities are for full open conditions and apply to the entire HON 680 range of regulators. However, to ensure optimum performance we recommend that only 85% of these capacities be used when sizing direct acting regulators

e.g. HON 680/680H MKI/E.V.A. Capacities stated are for appropriately sized expanded outlets.

TYPICAL CONTROL SYSTEMS

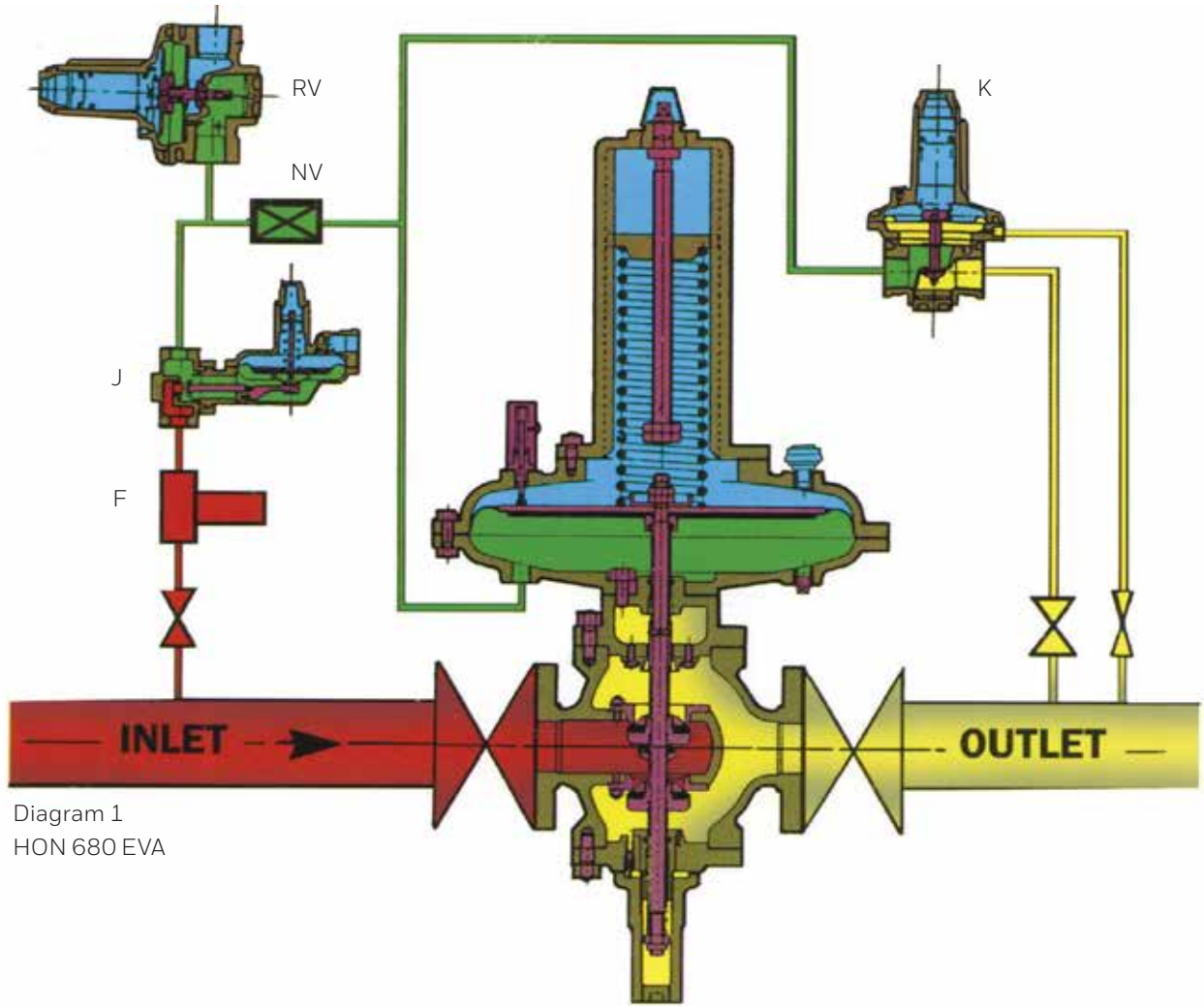
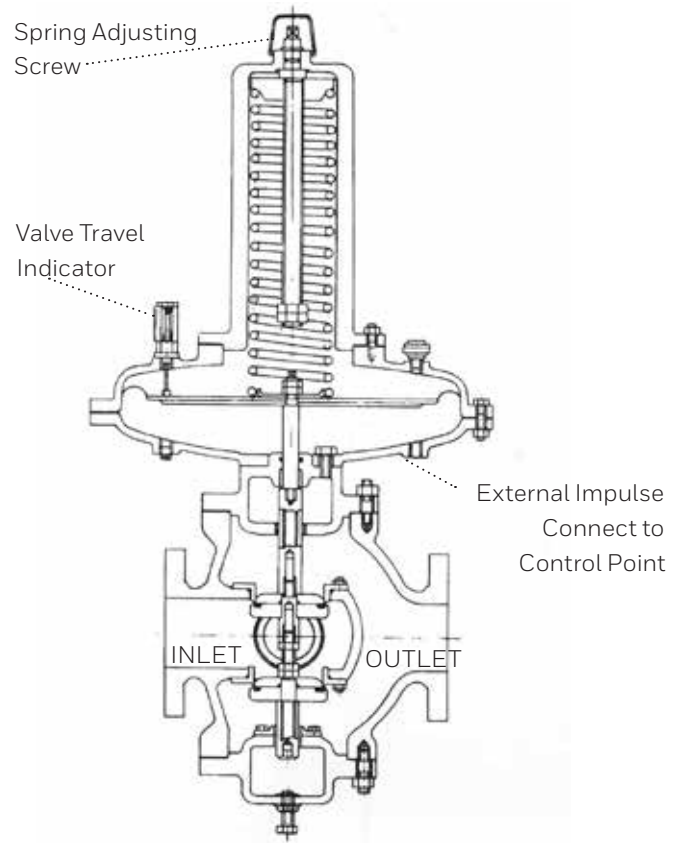

Diagram 1
HON 680 EVA

CONSTRUCTION

HON 680 MK1 Pressure Regulator

- The HON 680 Mk1 is based on a ductile iron, modular construction design enabling a common body to accept different internal valve arrangements and differently pressure-rated diaphragm heads applied to it. Thus the internal valves, which are stem-guided, may be arranged to fall open or fall closed and operate on full-bore or reduced bore orifices which may be changed or renewed in the field. While diaphragm heads are rarely changed in the field without a major change of usage, spring housings may be substituted readily and, if necessary a full scale conversation may be carried out to create a different model for fresh service conditions.
- All units are of robust and enclosed construction, suitable for outdoor location and most models may be installed in any mounting attitude.



HON 680 EVA Regulator

(MkII design "EVA" - external valve adjustment)

- A major refinement on models working on inlet pressures at 65 psig (4.5 bar) or lower is the facility to adjust the internal valve seating accuracy while the regulator remains on stream. This design of External Valve Adjustment, designated E.V.A. may be fitted retrospectively to Mk1 models.
- How the mechanism works is simple. The upper valve abuts to a sleeve shoulder on the stem and thus is fixed. The lower valve is moveable axially up and down the stem by a sleeve below it being advanced or retracted by the adjusting nut against the compression of the belleville washer stack separating the two valves.
- Valve setting is carried out simply by removing the cap from the bottom cover of the body and slowly rotating the adjusting nut until optimum valve closure performance is achieved. The operation is obviously best carried out when a standby supply stream or a bypass is available to meet gas demand in order to enable the regulator to be temporarily isolated and its lock-up tested against a closed outlet.
- The great advantage of this system is the avoidance of a total shutdown and purging the installation.

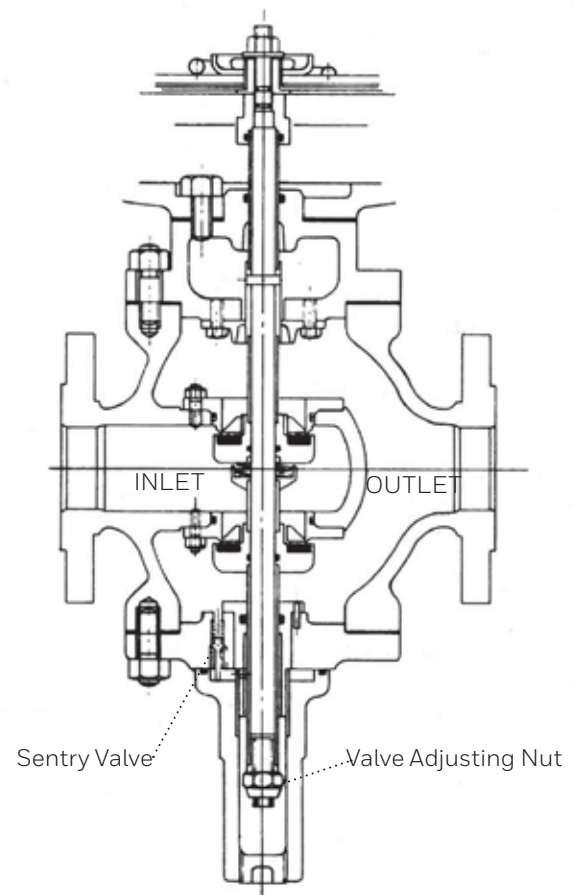

SECTIONAL ARRANGEMENT

HON 680 E.V.A. Regulator

Regulator

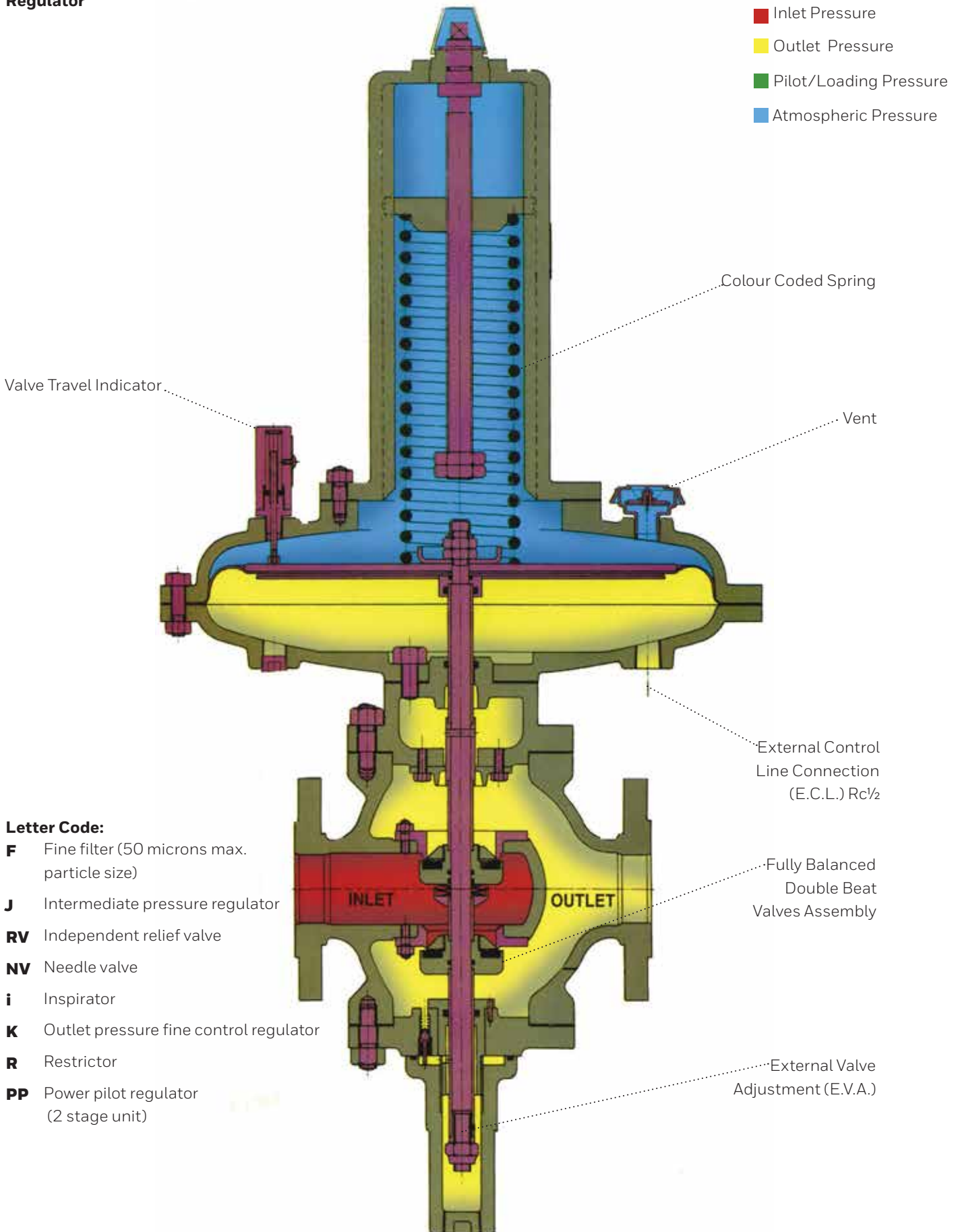

MATERIALS OF CONSTRUCTION

HON 680 - MK1	
Component	Material
Body, Diaphragm Casing, Spring Housing, Inspection Plates and Bottom Cover	Ductile Iron to BS EN 1563 Grade: EN-GJS-400-18
Spring	Carbon Steel: BS.5216
Valve Seats, Diaphragm Spindle, Bush, Valve Spindle and nut	Stainless Steel: BS.970 - 416S29
Diaphragm	Nitrile reinforced
'O' Rings	Nitrile
Adjusting Screw & Spring Button	Carbon Steel: BS.970 - 070M20
Valve Back	Carbon Steel: BS.970 - 070M20 Polyurethane filled

HON 680/680H - EVA	
Component	Material
Body, Diaphragm Casing, Spring Housing, Inspection Plates and Bottom Cover	Ductile Iron to BS EN 1563 Grade: EN-GJS-400-18
Spring	Carbon Steel: BS.5216
Valve Seats, Diaphragm Spindle, Bush, Valve Spindle and nut	
Diaphragm	Nitrile reinforced
'O' Rings & Valve Seat	Nitrile
Adjusting Screw & Spring Button	Carbon Steel: BS.970 - 070M20
Valve Back	Carbon Steel: BS.970 - 070M20



CONTROLS SUPPLY CHAIN®
VALVES ACTUATORS INSTRUMENTATIONS