

## Electrohydraulic Gas Valves (formerly SH) GH 5000 Series Class 1 Solenoid Gas Valves (formerly SA...KVS) GS2000 Series TABLES LISTING NEW INTERNATIONAL CODE NUMBERS

### Type GH Class 1 Electrohydraulic Valves Type GS Class 1 Solenoid Gas Valves

The development and upgrading of the Johnson Maclaren range of electrohydraulic and solenoid operated industrial gas valves has led to the production of improved models.

In order to distinguish the new improved products from the earlier models and at the same time avoid the problems of lengthened code numbers, it was decided to adopt the international coding system already in worldwide use by Johnson Controls

It should be emphasised that the new production has been carefully engineered to ensure interchangeability with earlier models, so that, for example, new actuators will fit valve bodies from earlier production

In order to assist in the changeover to the new codings, the tables which follow list the most common former SH and SA...KVS codes and relate these to the new international codes.

The new code defines the complete valve and its corresponding replacement actuator using two groups of numerals preceded by the Alpha characters GH (standing for Gas Hydraulic) and GS (standing for Gas Solenoid). For the electrohydraulic actuator, (replacement) the Alpha characters AH (standing for Actuator Hydraulic) are used. The codes are generally of 12 characters in length and it should be particularly noted that the hyphens between the numerical groups also count as characters, for computer

### New GH Electrohydraulic Valves Features:

- CPI switching now available over entire range
- IP54 rating over entire range (protected against dust ingress and water sprayed from all directions).
- Improved flow.
  - Wire mesh integral filters.
  - Safety shut-off.
  - Class 1, certified to BS5963
  - Robust construction.
  - Interchangeable actuators
- 240,220 & 110V 50/60Hz models available.

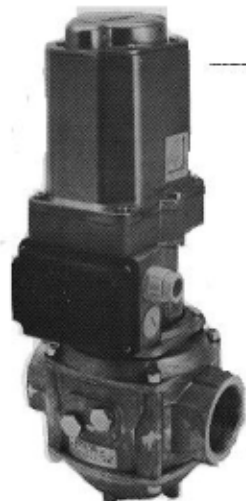

Type GH Valve up to 2" Threaded.  
Aluminium Die Cast Body.

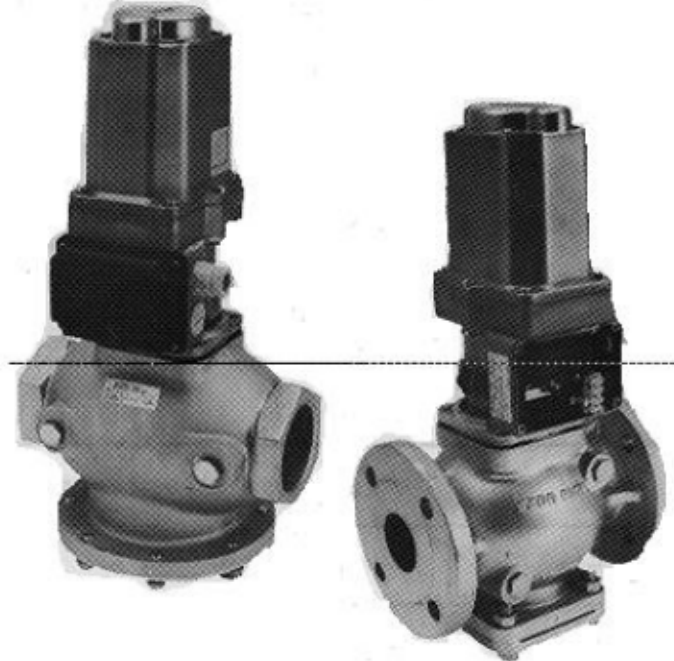

### New GS Solenoid Valves

#### Features:

- Available with Closed Position Indication (C.P.I) switch for all sizes in range. Consult factory.
- IP54 rating over entire range (protected against dust and sprayed water).
- Improved Flow. Class 1, certified to BS 5963 Safety shut-off. Robust construction. Natural or LP gases. Quick opening, step slow opening models with adjustable flow
- Interchangeable actuators.
- 240,220,110, 24 Volt 50/60Hz and 24V,12V DC models available.

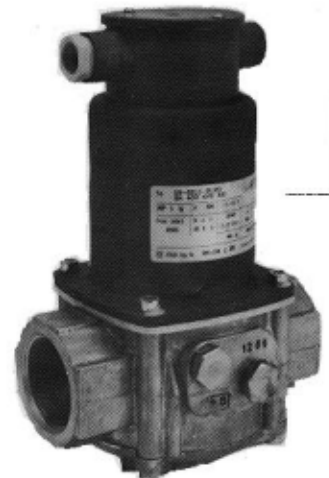

Type GS Solenoid Valves  
Fast Opening 1/2"2 BSPP

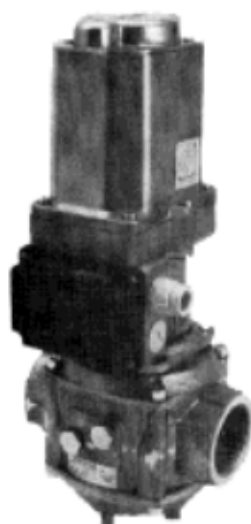
**240V (SCREWED)**

COMPLETE VALVES (SCREWED,Rp)				REPLACEMENT ACTUATORS	
TYPE	Rp	NEW CODE	WAS	NEW CODE	WAS
On/Off Series 240V 50/60Hz	¾	GH-5110-2120	SH111NVS20	AH-5100-0120	SH111
	1	GH-5110-3120	SH111NVS25	AH-5100-0120	SH111
	1 1/2	GH-5110-5120	SH111NVSL40	AH-5100-0120	SH111
	2	GH-5210-6120	SH211NVSL50	AH-5200-0120	SH211
	2 1/2	*GH-5210-7120	SH211NVS65	AH-5200-0120	SH211
	3	*GH-5210-8120	SH211NVS80	AH-5200-0120	SH211
High/Low/Off Series 240V 50/60Hz	¾	GH-5110-2321	SH131NVS20S	AH-5100-0320	SH131
	1	GH-5110-3321	SH131NVS25S	AH-5100-0320	SH131
	1 1/2	GH-5110-5321	SH131NVSL40S	AH-5100-0320	SH131
	2	GH-5210-6321	SH231NVSL50	AH-5200-0320	SH231
	2 1/2	*GH-5210-7321	SH231NVS65	AH-5200-0320	SH231
	3	*GH-5210-8321	SH231NVS80	AH-5200-0320	SH231
On/Off Series with CPI 240V 50/60Hz	1	GH-5119-3621	SH161CNVS25S	AH-5109-0620	SH161C
	1 1/2	GH-5119-5621	SH161CNVSL40S	AH-5109-0620	SH161C
	2	GH-5219-6621	SH261CNVSL50S	AH-5209-0620	SH261C
	2 1/2	*GH-5219-7621	SH261CNVS65S	AH-5209-0620	SH261C
	3	*GH-5219-8621	SH261CNVS80S	AH-5209-0620	SH261C
High/Low/Off Series with CPI 240V 50/60Hz	1	GH-5119-3421	SH141CNVS25S	AH-5109-0420	SH141C
	1 1/2	GH-5119-5421	SH141CNVSL40S	AH-5109-0420	SH141C
	2	GH-5219-6421	SH241CNVSL50S	AH-5209-0420	SH241C
	2 1/2	*GH-5219-7421	SH241CNVS65S	AH-5209-0420	SH241C
	3	*GH-5219-8421	SH241CNVS80S	AH-5209-0420	SH241C

\*NOTE: See Supplement Page 9 for advance information on codes for new 2 1/2" and 3" screwed models.

**220V (SCREWED)**

COMPLETE VALVES\$SCREWED,Rp)				REPLACEMENT ACTUATORS	
TYPE	Rp	NEW CODE	WAS	NEW CODE	WAS
On/Off Series 220V 50/60Hz	¾	GH-5110-2110	SH110NVS20	AH-5100-0110	SH110
	1	GH-5110-3110	SH110NVS25	AH-5100-0110	SH110
	1 1/2	GH-5110-5110	SH110NVSL40	AH-5100-0110	SH110
	2	GH-5210-6110	SH210NVSL50	AH-5200-0110	SH210
	2 1/2	*GH-5210-7110	SH210NVS65	AH-5200-0110	SH210
	3	*GH-5210-8110	SH210NVS80	AH-5200-0110	SH210
High/Low/Off Series 220V 50/60Hz	¾	GH-5110-2311	SH130NVS20S	AH-5100-0310	SH130
	1	GH-5110-3311	SH130NVS25S	AH-5100-0310	SH130
	1 1/2	GH-5110-5311	SH130NVSL40S	AH-5100-0310	SH130
	2	GH-5210-6311	SH230NVSL50	AH-5200-0310	SH230
	2 1/2	*GH-5210-7311	SH230NVS65	AH-5200-0310	SH230
	3	*GH-5210-8311	SH230NVS80	AH-5200-0310	SH230
On/Off Series with CPI 220V 50/60Hz	1	GH-5119-3611	SH160CNVS25S	AH-5109-0610	SH160C
	1 1/2	GH-5119-5611	SH160CNVSL40S	AH-5109-0610	SH160C
	2	GH-5219-6611	SH260CNVSL50S	AH-5209-0610	SH260C
	2 1/2	*GH-5219-7611	SH260CNVS65S	AH-5209-0610	SH260C
	3	*GH-5219-8611	SH260CNVS80S	AH-5209-0610	SH260C
High/Low/Off Series with CPI 220V 50/60Hz	1	GH-5119-3411	SH140CNVS25S	AH-5109-0410	SH140C
	1 1/2	GH-5119-5411	SH140CNVSL40S	AH-5109-0410	SH140C
	2	GH-5219-6411	SH240CNVSL50S	AH-5209-0410	SH240C
	2 1/2	*GH-5219-7411	SH240CNVS65S	AH-5209-0410	SH240C
	3	*GH-5219-8411	SH240CNVS80S	AH-5209-0410	SH240C

**110V (SCREWED)**

COMPLETE VALVES\$SCREWED,Rp)				REPLACEMENT ACTUATORS	
TYPE	Rp	NEW CODE	WAS	NEW CODE	WAS
On/Off Series 110V 50/60Hz	¾	GH-5110-2130	SH112NVS20	AH-5100-0130	SH112
	1	GH-5110-3130	SH112NVS25	AH-5100-0130	SH112
	1 1/2	GH-5110-5130	SH112NVSL40	AH-5100-0130	SH112
	2	GH-5210-6130	SH212NVSL50	AH-5200-0130	SH212
	2 1/2	*GH-5210-7130	SH212NVS65	AH-5200-0130	SH212
	3	*GH-5210-8130	SH212NVS80	AH-5200-0130	SH212
High/Low/Off Series 110V 50/60Hz	¾	GH-5110-2331	SH132NVS20S	AH-5100-0330	SH132
	1	GH-5110-3331	SH132NVS25S	AH-5100-0330	SH132
	1 1/2	GH-5110-5331	SH132NVSL40S	AH-5100-0330	SH132
	2	GH-5210-6331	SH232NVSL50	AH-5200-0330	SH232
	2 1/2	*GH-5210-7331	SH232NVS65	AH-5200-0330	SH232
	3	*GH-5210-8331	SH232NVS80	AH-5200-0330	SH232
On/Off Series with CPI 110V 50/60Hz	1	GH-5119-3631	SH162CNVS25S	AH-5109-0630	SH162C
	1 1/2	GH-5119-5631	SH162CNVSL40S	AH-5109-0630	SH162C
	2	GH-5219-6631	SH262CNVSL50S	AH-5209-0630	SH262C
	2 1/2	*GH-5219-7631	SH262CNVS65S	AH-5209-0630	SH262C
	3	*GH-5219-8631	SH262CNVS80S	AH-5209-0630	SH262C
High/Low/Off Series with CPI 110V 50/60Hz	1	GH-5119-3431	SH142CNVS25S	AH-5109-0430	SH142C
	1 1/2	GH-5119-5431	SH142CNVSL40S	AH-5109-0430	SH142C
	2	GH-5219-6431	SH242CNVSL50S	AH-5209-0430	SH242C
	2 1/2	*GH-5219-7431	SH242CNVS65S	AH-5209-0430	SH242C
	3	*GH-5219-8431	SH242CNVS80S	AH-5209-0430	SH242C

\*NOTE: See Supplement Page 9 for advance information on codes for new 2/2" and 3" screwed models.

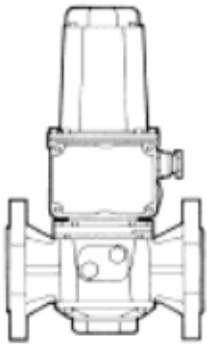

DN 40 Valve

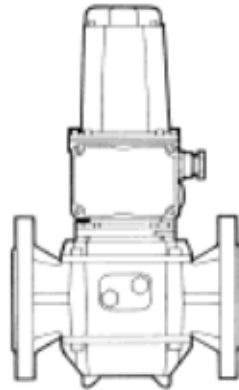

DN 50 Valve

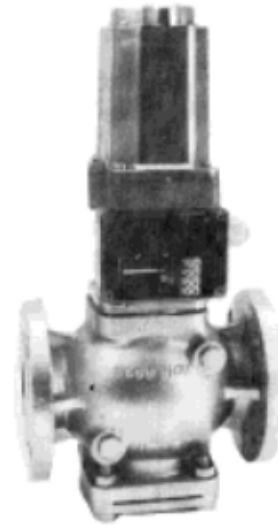

DN 65-150 Valve

**240V (FLANGED)**

COMPLETE VALVES (FLANGED)				REPLACEMENT ACTUATORS	
TYPE	DN	NEW CODE	WAS	NEW CODE	WAS
On/Off Series 240V 50/60Hz	40	GH-5120-1120	**	AH-5100-0120	
	50	GH-5220-2120	SH211NVF50	AH-5200-0120	SH211
	65	GH-5220-3120	SH211NVF65	AH-5200-0120	SH211
	80	GH-5220-4120	SH211NVF80	AH-5200-0120	SH211
	100	GH-5420-5120	SH411NVF100	AH-5400-0120	SH411
	125	GH-5420-6120	SH411NVF125	AH-5400-0120	SH411
	150	GH-5420-7120	SH411NVF150	AH-5400-0120	SH411
High/Low/Off Series 240V 50/60Hz	40	GH-5120-1321		AH-5100-0320	
	50	GH-5220-2321	SH231NVF50S	AH-5200-0320	SH231
	65	GH-5220-3321	SH231NVF65S	AH-5200-0320	SH231
	80	GH-5220-4321	SH231NVF80S	AH-5200-0320	SH231
	100	GH-5420-5321	SH411NVF100S	AH-5400-0320	SH431
	125	GH-5420-6321	SH411NVF125S	AH-5400-0320	SH431
	150	GH-5420-7321	SH411NVF150S	AH-5400-0320	SH431
On/Off Series with CPI 240V 50/60Hz	40	GH-5129-1621		AH-5109-0620	
	50	GH-5229-2621	SH261CNVF50S	AH-5209-0620	SH261C
	65	GH-5229-3621	SH261CNVF65S	AH-5209-0620	SH261C
	80	GH-5229-4621	SH261CNVF80S	AH-5209-0620	SH261C
	100	GH-5429-5621	SH461CNVF100S	AH-5409-0620	SH461C
	125	GH-5429-6621	SH461NVF125S	AH-5409-0620	SH461C
	150	GH-5429-7621	SH461NVF150S	AH-5409-0620	SH461C
High/Low/Off Series with CPI 240V 50/60Hz	40	GH-5129-1421		AH-5109-0420	
	50	GH-5229-2421	SH241CNVF50S	AH-5209-0420	SH241C
	65	GH-5229-3421	SH241CNVF65S	AH-5209-0420	SH241C
	80	GH-5229-4421	SH241CNVF80S	AH-5209-0420	SH241C
	100	GH-5429-5421	SH441CNVF100S	AH-5409-0420	SH441C
	125	GH-5429-6421	SH441NVF125S	AH-5409-0420	SH441C
	150	GH-5429-7421	SH441NVF150S	AH-5409-0420	SH441C

\*NOTE: See Supplement Page 10 for advance information on codes for new DN65 and 80 flanged models.

## 220V (FLANGED)

COMPLETE VALVES (FLANGED)				REPLACEMENT ACTUATORS	
TYPE	DN	NEW CODE	WAS	NEW CODE	WAS
On/Off Series 220V 50/60Hz	40	GH-5120-1120	**	AH-5100-0110	
	50	GH-5220-2120	SH210NVF50	AH-5200-0110	SH210
	65	GH-5220-3120	SH210NVF65	AH-5200-0110	SH210
	80	GH-5220-4120	SH210NVF80	AH-5200-0110	SH210
	100	GH-5420-5110	SH410NVF100	AH-5400-0110	SH410
	125	GH-5420-6110	SH410NVF125	AH-5400-0110	SH410
	150	GH-5420-7110	SH410NVF150	AH-5400-0110	SH410
High/Low/Off Series 220V 50/60Hz	40	GH-5120-1311		AH-5100-0310	
	50	GH-5220-2311	SH230NVF50S	AH-5200-0310	SH230
	65	GH-5220-3311	SH230NVF65S	AH-5200-0310	SH230
	80	GH-5220-4311	SH230NVF80S	AH-5200-0310	SH230
	100	GH-5420-5311	SH430NVF100S	AH-5400-0310	SH430
	125	GH-5420-6311	SH430NVF125S	AH-5400-0310	SH430
	150	GH-5420-7311	SH430NVF150S	AH-5400-0310	SH430
On/Off Series with CPI 220V 50/60Hz	40	GH-5129-1611		AH-5109-0610	
	50	GH-5229-2611	SH260CNVF50S	AH-5209-0610	SH260C
	65	GH-5229-3611	SH260CNVF65S	AH-5209-0610	SH260C
	80	GH-5229-4611	SH260CNVF80S	AH-5209-0610	SH260C
	100	GH-5429-5611	SH460CNVF100S	AH-5409-0610	SH460C
	125	GH-5429-6611	SH460NVF125S	AH-5409-0610	SH460C
	150	GH-5429-7611	SH460NVF150S	AH-5409-0610	SH460C
High/Low/Off Series with CPI 240V 50/60Hz	40	GH-5129-1411		AH-5109-0410	
	50	GH-5229-2411	SH240CNVF50S	AH-5209-0410	SH240C
	65	GH-5229-3411	SH240CNVF65S	AH-5209-0410	SH240C
	80	GH-5229-4411	SH240CNVF80S	AH-5209-0410	SH240C
	100	GH-5429-5411	SH440CNVF100S	AH-5409-0410	SH440C
	125	GH-5429-6411	SH440NVF125S	AH-5409-0410	SH440C
	150	GH-5429-7411	SH440NVF150S	AH-5409-0410	SH440C

\*\* NEW SIZE - NOT PREVIOUSLY AVAILABLE.

## 110V (FLANGED)

COMPLETE VALVES (FLANGED)				REPLACEMENT ACTUATORS	
TYPE	DN	NEW CODE	WAS	NEW CODE	WAS
On/Off Series 220V 50/60Hz	40	GH-5120-1130	**	AH-5100-0130	
	50	GH-5220-2130	SH212NVF50	AH-5200-0130	SH212
	65	GH-5220-3130	SH212NVF65	AH-5200-0130	SH212
	80	GH-5220-4130	SH212NVF80	AH-5200-0130	SH212
	100	GH-5420-5130	SH412NVF100	AH-5400-0130	SH412
	125	GH-5420-6130	SH412NVF125	AH-5400-0130	SH412
	150	GH-5420-7130	SH412NVF150	AH-5400-0130	SH412
High/Low/Off Series 220V 50/60Hz	40	GH-5120-1331		AH-5100-0330	
	50	GH-5220-2331	SH232NVF50S	AH-5200-0330	SH232
	65	GH-5220-3331	SH232NVF65S	AH-5200-0330	SH232
	80	GH-5220-4331	SH232NVF80S	AH-5200-0330	SH232
	100	GH-5420-5331	SH432NVF100S	AH-5400-0330	SH432
	125	GH-5420-6331	SH432NVF125S	AH-5400-0330	SH432
	150	GH-5420-7331	SH432NVF150S	AH-5400-0330	SH432
On/Off Series with CPI 220V 50/60Hz	40	GH-5129-1631		AH-5109-0630	
	50	GH-5229-2631	SH262CNVF50S	AH-5209-0630	SH262C
	65	GH-5229-3631	SH262CNVF65S	AH-5209-0630	SH262C
	80	GH-5229-4631	SH262CNVF80S	AH-5209-0630	SH262C
	100	GH-5429-5631	SH462CNVF100S	AH-5409-0630	SH462C
	125	GH-5429-6631	SH462NVF125S	AH-5409-0630	SH462C
	150	GH-5429-7631	SH462NVF150S	AH-5409-0630	SH462C
High/Low/Off Series with CPI 240V 50/60Hz	40	GH-5129-1431		AH-5109-0430	
	50	GH-5229-2431	SH242CNVF50S	AH-5209-0430	SH242C
	65	GH-5229-3431	SH242CNVF65S	AH-5209-0430	SH240C
	80	GH-5229-4431	SH242CNVF80S	AH-5209-0430	SH242C
	100	GH-5429-5431	SH442CNVF100S	AH-5409-0430	SH442C
	125	GH-5429-6431	SH442NVF125S	AH-5409-0430	SH442C
	150	GH-5429-7431	SH442NVF150S	AH-5409-0430	SH442C

\*NOTE: See Supplement Page 10 for advance information on codes for new DN65 and 80 flanged models.

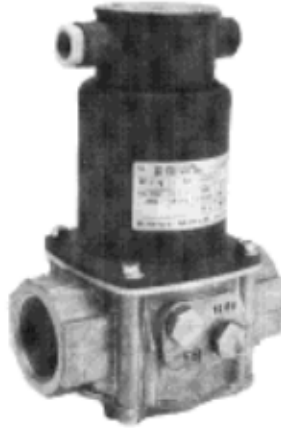
**240V (SCREWED) SOLENOID**

COMPLETE VALVES \$CRAWLED, Rp)				REPLACEMENT ACTUATORS	
TYPE	Rp	NEW CODE	WAS	NEW CODE	WAS
Quick Opening 240V 50/60Hz	1/2	GS-2011-2120	SA103KVS151	626-1130-001	SA103
	3/4	GS-2011-3120	SA203KVS201	626-2130-001	SA203
	1	GS-2011-4120	SA303KVS251 (SA603KVS251)	626-3130-001	SA303
	1 1/2	GS-2011-5120	SA403KVS401 (SA703KVS401)	626-4130-001	SA403
	2	GS-2011-6120	SA505KVS401	626-5130-001	SA503
Quick Opening Adjustable Flow 240V 50/60Hz	1/2	GS-2011-2220	SA103KVS152	626-1130-001	SA103
	3/4	GS-2011-3220	SA203KVS202	626-2130-001	SA203
	1	GS-2011-4220	SA303KVS252 (SA604KVS251)	626-3130-001	SA303
	1 1/2	GS-2011-5220	SA403KVS402 (SA703KVS402)	626-4130-001	SA403
Step Slow Opening 240V 50/60Hz	3/4	GS-2011-3320	SA204KVS203	626-2140-001	SA204
	1	GS-2011-4320	SA304KVS253	626-3140-001	SA304
	1 1/2	GS-2011-5320	SA404KVS403	626-4140-001	SA404
Step Slow Opening Adjustable Flow 240V 50/60Hz	1/2	GS-2011-2430	SA105KVS154	626-1140-001	SA104
	3/4	GS-2011-3430	SA205KVS204	626-2140-001	SA204
	1	GS-2011-4430	SA305KVS254	626-3140-001	SA304
	1 1/2	GS-2011-5430	SA405KVS404	626-4140-001	SA404

Note: All above models are also available for 220V/50/60Hz. Consult factory

**IMPORTANT: ALL SOLENOID VALVES LISTED ON PAGES 6 & 7 CAN ALSO BE SUPPLIED WITH CLOSED POSITION INDICATION (C.P.I.) SWITCH- CONSULT FACTORY.**

**24V D.C./24V 50HZ/12V D.C./SCREWED] SOLENOID**

COMPLETE VALVES\$CREWED,Rp)				REPLACEMENT ACTUATORS	
TYPE	Rp	NEW CODE	WAS	NEW CODE	WAS
Quick Opening 24V D.C.	1/2	GS-2011-2150	SA108KVS151	626-1180-001	SA108
	3/4	GS-2011-3150	SA208KVS201	626-2180-001	SA208
	1	GS-2011-4150	SA308KVS251	626-3180-001	SA308
	1 1/2	GS-2011-5150	SA408KVS401	626-4180-001	SA408
Quick Opening 24V 50/60Hz	1/2	GS-2011-2140	SA106KVS151	626-1160-001	SA106
	3/4	GS-2011-3140	SA206KVS201	626-2160-001	SA206
	1	GS-2011-4140	SA306KVS251	626-3160-001	SA306
	1 1/2	GS-2011-5140	SA406KVS401	626-4160-001	SA406
Step Slow Opening 24V 50/60Hz	1	GS-2011-4340	SA306KVS253	626-3160-001	SA306
	1 1/2	GS-2011-5340	SA406KVS403	626-4160-001	SA406
Quick Opening 12V D.C.	1/2	GS-2011-2160	SA107KVS151	626-1170-001	SA107
	3/4	GS-2011-3160	SA207KVS201	626-2170-001	SA207
	1	GS-2011-4160	SA307KVS251	626-3170-001	SA307
	1 1/2	GS-2011-5160	SA407KVS401	626-4170-001	SA407

**110V (SCREWED) SOLENOID**

COMPLETE VALVES\$CREWED,Rp)				REPLACEMENT ACTUATORS	
TYPE	Rp	NEW CODE	WAS	NEW CODE	WAS
Quick Opening 110V 50/60Hz	1/2	GS-2011-2130	SA105KVS151	626-1150-001	SA105
	3/4	GS-2011-3130	SA205KVS201	626-2150-001	SA205
	1	GS-2011-4130	SA305KVS251	626-3150-001	SA305
	1 1/2	GS-2011-5130	SA405KVS401	626-4150-001	SA405
	2	GS-2011-6130	SA505KVS401	626-5150-001	SA505
Quick Opening Adjustable Flow 110V 50/60Hz	1/2	GS-2011-2230	SA105KVS152	626-1150-001	SA105
	3/4	GS-2011-3230	SA205KVS202	626-2150-001	SA205
	1	GS-2011-4230	SA305KVS252	626-3150-001	SA305
	1 1/2	GS-2011-5230	SA405KVS402	626-4150-001	SA405
Step Slow Opening 110V 50/60Hz	1	GS-2011-4330	SA305KVS253	626-3150-001	SA305
	1 1/2	GS-2011-5330	SA405KVS403	626-4150-001	SA405
Step Slow Opening Adjustable Flow 110V 50/60Hz	1/2	GS-2011-2430	SA105KVS154	626-1150-001	SA105
	3/4	GS-2011-3430	SA205KVS204	626-2150-001	SA205
	1	GS-2011-4430	SA305KVS254	626-3150-001	SA305
	1 1/2	GS-2011-5430	SA405KVS404	626-4150-001	SA405

**TYPE GH 5000 VALVE  
ELECTROHYDRAULIC**

Users are reminded of their responsibility to ensure that all Johnson ControlsMaclaren Products are used in a manner which is safe and in compliance with local laws and regulations and without risks to health and property.

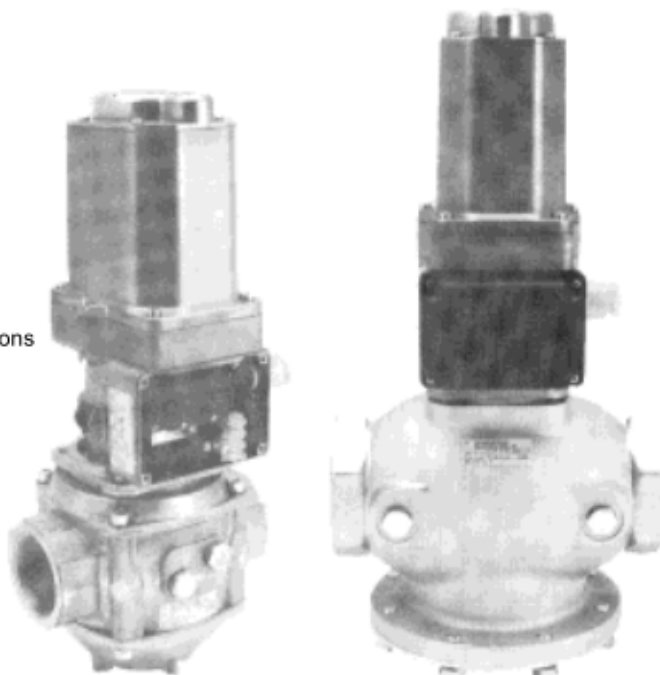

**TYPE GS 2000 SOLENOID VALVES**

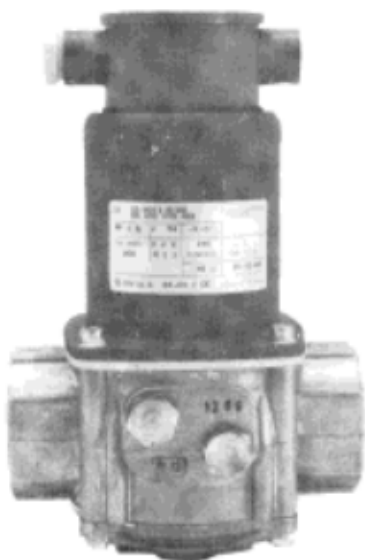

Fast opening 1/2" - 2" BSP

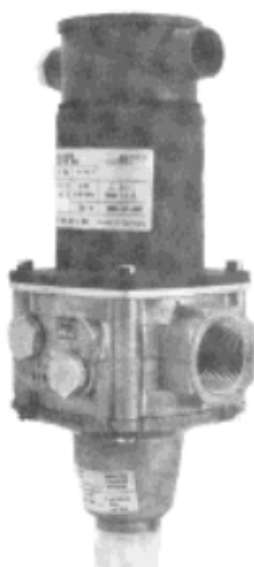

Step slow opening 1/2" - 1 1/2" BSP

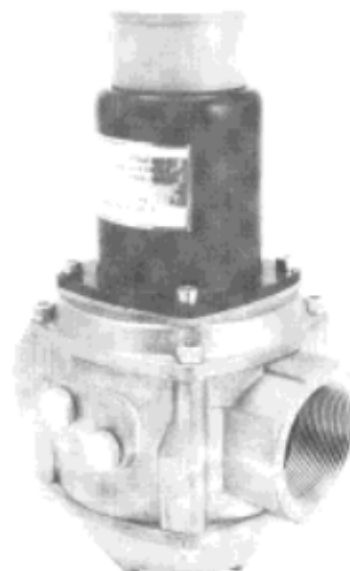

Fast opening 2" size only

Leaflet subject to change without prior notice  
JOHNSON CONTROLS PRODUCTS GROUP



## GS 2000 Class 1 Gas Safety Shutoff Valves Solenoid Operated

### GS2000 Gas Safety Solenoid Operated Valves

This valve series meets industrial requirements for robust and maintenance free solenoid valves.

These single seat two-way valves with solenoid actuator for vertical and horizontal mounting, are suitable for manufactured, natural and L.P. gases. Type GS2000 valves are particularly suitable for control of main gas lines on commercial and industrial power and atmospheric gas burners, meeting the requirements for Class 1 applications and suitable for forced and induced draught gas burners and burner trains.

Of robust construction throughout. The range of operating modes' includes Class 1 series fast opening, fast opening with adjustable flow, steps slow opening and step slow opening with adjustable flow.

The silent operation of the slow opening versions is an attractive feature for commercial and residential applications.

### Operation

When the valve is de-energised, the spring loaded valve plug is pressed against the seat to provide tight shut off. When the valve is energised, direct current is supplied through an overload-protected rectifier, incorporated in the valve terminal head, to the Solenoid coil. The magnetic field generated by this coil forces the valve plug from the seat to open the valve downward against the spring and flow medium pressure.

The actuator plunger is guided in a PTFE bearing and provides for maintenance free operation under temperature and pressure conditions within valve specifications. A seal protects the plunger cylinder from the entry of impurities which may be carried by the flow-medium and the valve's seating surfaces and appliance components are additionally protected by a built-in wire-mesh filter.

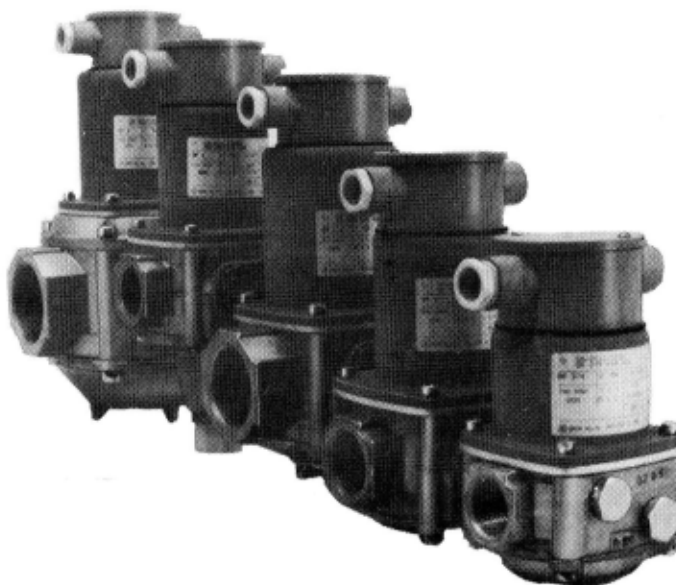

### Specification

<b>Product:</b>	GS 2000 Class 1 Gas Safety Shut-Off Valves -Solenoid Operated	
<b>Service:</b>	Natural or L.P. gases (i.e. Propane, Butane)	
<b>Mounting:</b>	Vertical and horizontal.	
<b>Materials:</b>	Valve body, up to 2" diecast aluminum.	Flanges: PN/6 to DIN 2501
<b>Charact./Seating:</b>	Magnet Housing: steel on/off with disc type NBR soft seat.	
<b>Temperature:</b>	Ambient - 15 to + 60°C	
<b>Electrical Connection:</b>	Cable compression gland for cables 7-12 mm dia, Pg 13.5 - screw terminals	
<b>Actuator:</b>	Direct current solenoid. Overload protected rectifier.	
<b>Voltages:</b>	220V, 240V, 110V or 24V*, 50-60Hz	(+ 10%) (* except DN 50) (- 15%)
<b>Power Rating:</b>	DN 15 = 21 VA, DN 20 = 25 VA, DN 25 = 32, VA, DN 40 = 46 VA, DN 50 = 55 VA	

<b>Type 1:</b>	Fast opening and closing.
<b>Type 2:</b>	Fast opening and closing with adjustable flow
<b>Type 3:</b>	Step slow opening, fast closing with adjustable low start rate.
<b>Type 4:</b>	Step slow opening, fast closing with adjustable low start rate and adjustable max. flow.
<b>Opening Time:</b>	Fast opening = max 1 sec. Slow opening max. 25 sec.
<b>Closing Time:</b>	Max 1 sec.
<b>Permissible Operating Sequence</b>	Fast opening = 20 per minute Slow opening = 1 per minute
<b>Switch-on Time:</b>	100%
<b>Pressure Tappings:</b>	All valve bodies have Rp 1/4 Tappings. 2 - Inlet side 2 - Outlet side
<b>Enclosure:</b>	IP 54 (DIN 40 050)

## 2. GS 2000 RANGE CLASS 1 SOLENOID OPERATED

### Valve Action

Fast opening type: On energising, valve goes immediately to a fully open position, or a position determined by Flow Adjuster, if fitted. **Step slow opening type:** On energising valve goes immediately to an opening determined by Flow Adjuster, if fitted. Maximum time from first step to maximum open position is 25 seconds depending on initial setting.

First step setting is adjustable between 10 and 60% of stroke.

To adjust, remove plastic cap (9) at base of valve and carefully turn large (19mm) hexagonal nut (7) clockwise, to reduce flow and anticlockwise to increase flow.

Effective adjustment range is achieved with half turn.

**NOTE:** Valve action from a closed position to a maximum open position is continuous i.e. Fast to first step and then immediately slow to maximum open position. The slow opening stroke is controlled by an hydraulic damper located in the extension at the base of the valve.

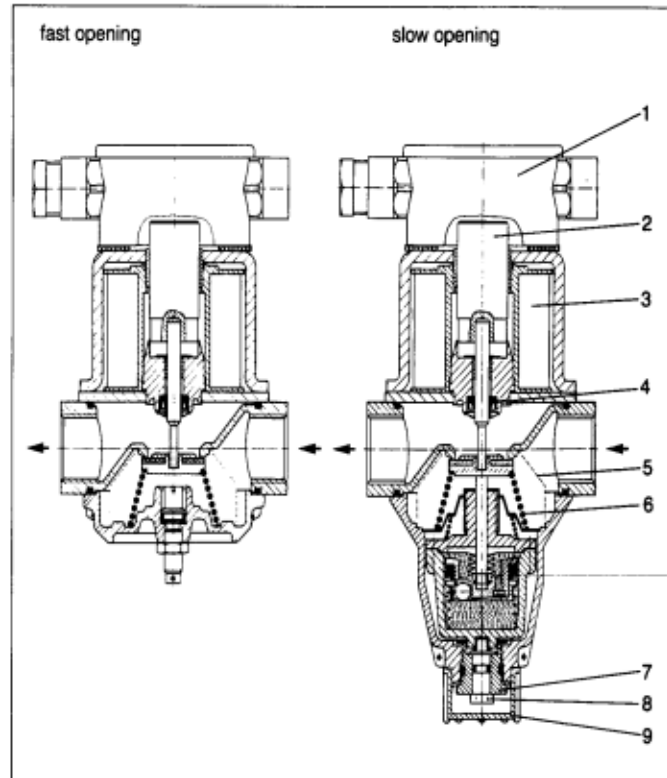

- 1 Terminal Head
- 2 Plunger
- 3 Solenoid Coil
- 4 Seal
- 5 Wire mesh screen

- 6 Valve Spring
- 7 Step Adjuster
- 8 Max. Flow Adjuster
- 9 Protective cap

### GS2000 RANGE OF 240V (SCREWED) SOLENOID VALVES

COMPLETED VALVES (SCREWED, Rp)				FLOW NATURAL GAS AT 2.5 mbar (1" WG)		RESPONSE TIME		MAX. WORKING PRESSURE	REPLACEMENT ACTUATOR CODE NO	OLD CODE WAS
TYPE	Rp	NEW CODE	WAS	M <sup>3</sup> /hr	ft <sup>3</sup> /hr	OPENING sec	CLOSING sec			
Quick Opening	½	GS-2011-2120	SA103KVS151	7.74	273	Max 1	Max 1	200	616-1130-001	SA103
240V50/60Hz**	¾	GS-2011-3120	SA203KVS201	12.64	446	Max 1	Max 1	200	626-2130-001	SA203
	1	GS-2011-4120	SA303KVS251	20.64	729	Max 1	Max 1	200	626-3130-001	SA303
On/Off	1 ½	GS-2011-5120	SA403KVS401	43.86	1549	Max 1	Max 1	200	626-4130-001	SA403
Type 1*	2	GS-2011-6120	SA503KVS501	78.69	2779	Max 2	Max 1	200	626-5130-001	SA503
Quick Opening	½	GS-2011-2220	SA103KVS152	7.74	273	Max 1	Max 1	200	616-1130-001	SA103
Adjustable Flow 240V50/60Hz**	¾	GS-2011-3220	SA203KVS202	12.64	446	Max 1	Max 1	200	626-2130-001	SA203
	1	GS-2011-4220	SA303KVS252	20.64	729	Max 1	Max 1	200	626-3130-001	SA303
	1 ½	GS-2011-5220	SA403KVS402	43.86	1549	Max 1	Max 1	200	626-4130-001	SA403
Type 2*										
Step slow Opening	¾	GS-2011-3320	SA204KVS203	7.74	273	Max 25	Max 1	200	626-2140-001	SA204
240V50/60Hz**	1	GS-2011-4320	SA304KVS253	12.64	446	Max 25	Max 1	200	626-3140-001	SA304
	1 ½	GS-2011-5320	SA404KVS403	20.64	729	Max 25	Max 1	200	626-4140-001	SA404
Type 3*										
Step slow Opening	½	GS-2011-2420	SA104KVS154	7.74	273	Max 25	Max 1	200	616-1140-001	SA104
Adjustable Flow 240V50/60Hz**	¾	GS-2011-3420	SA204KVS204	12.64	446	Max 25	Max 1	200	626-2140-001	SA204
	1	GS-2011-4420	SA304KVS254	20.64	729	Max 25	Max 1	200	626-3140-001	SA304
	1 ½	GS-2011-5420	SA404KVS404	43.86	1549	Max 25	Max 1	200	626-4140-001	SA404
Type 4*										

Type 1 = Class 1 Fast Opening and Closing On/Off

Type 2 = Class 1 Fast Opening and Closing with Max. Adjustable Flow

Type 3 = Class 1 Step Slow Opening, Fast Closing with Adjustable Low Start Rate

Type 4 = Class 1 Step Slow Opening, Fast Closing with Adjustable Low Start Rate and Adjustable Flow.

**IMPORTANT:** All above solenoid valves can be supplied with closed position indication (C.P.I.) switch.

**NOTE:** m<sup>3</sup>/h x 35.315 = ft<sup>3</sup>/hr.

**NOTE 2:** For code numbers for 24V DC/24V 50HZ/12V DC and 110V, See Separate Coding Leaflet.

## GS 2000 RANGE CLASS 1 SOLENOID OPERATED VALVES.

GS 2000 CLASS 1 SOLENOID VALVES: FLOW DIAGRAM

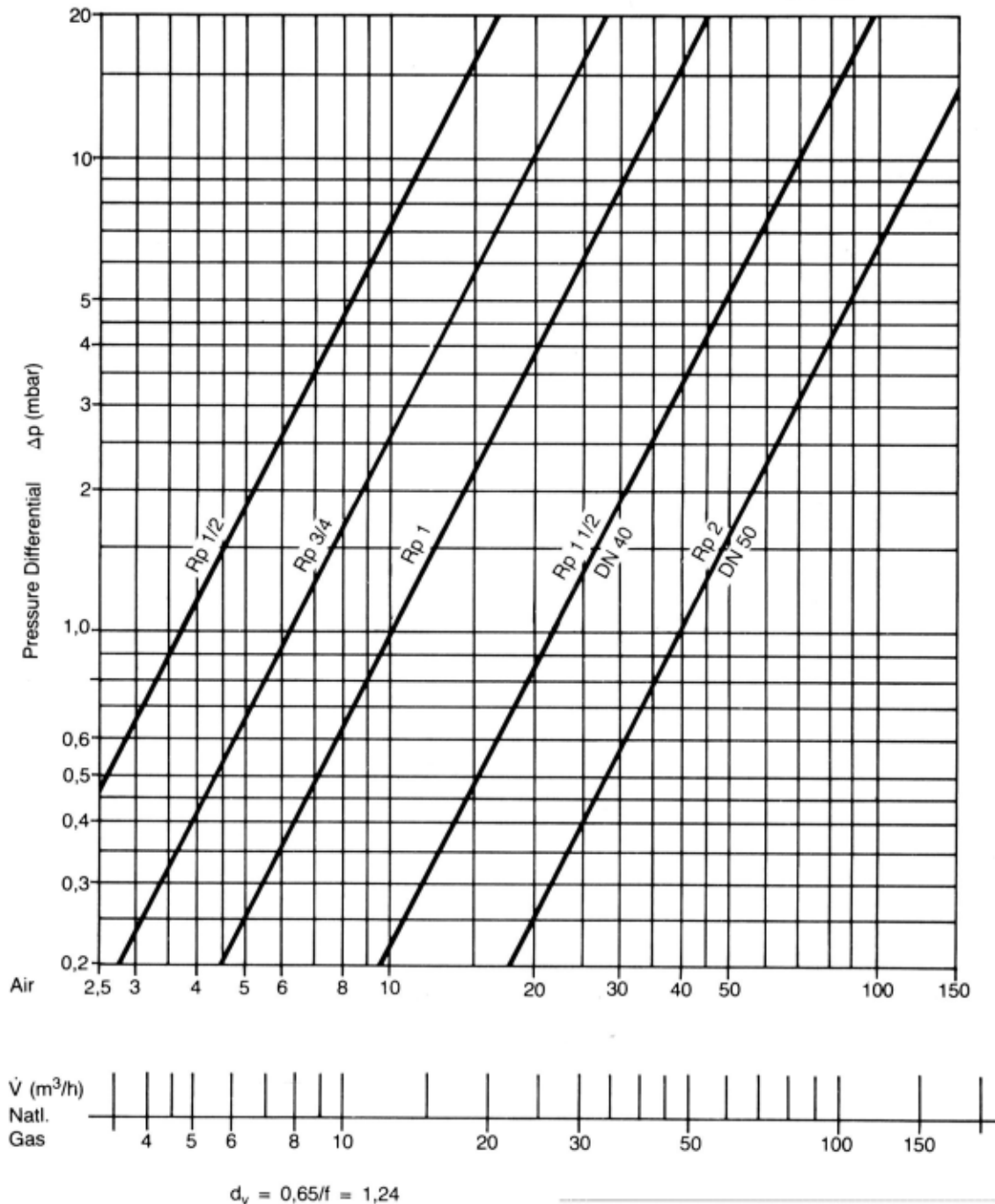

### Valves fitted with Flow Adjuster Fast or SlowType.

Adjustment is by means of small (8mm) hexagonal nut (8) located at base of valve.

Turn clockwise to reduce flow.

Maximum adjustment approx. 5 turns for 1/2 & 3/4 sizes, approx. 8 turns for 1, 1 1/2 & 2" sizes.

#### Note:

First adjust step setting if applicable, then max. flow setting.

Thereafter check step adjustment.

Do not force adjustment beyond stop.

**Installation** 1. Valves must be installed in conformance with flow direction arrows cast into valve ports for proper operation

2. Ambient temperature must not exceed limits specified.
3. Pipes should be cleared of all impurities prior to valve connection.
4. Any sealants should be applied to male thread of pipe and NOT to female thread of valve.
5. DO NOT USE VALVE ACTUATOR AS A LEVER WHEN TURNING VALVE ON TO PIPE. USE CORRECT TOOLS OVER FLATS OF VALVE PORT FACES.
6. Install vertically wherever possible.

Users are reminded of their responsibility to ensure that all Johnson Controls Products are used in a manner which is safe and without risks to health and to comply with local laws and regulations.  
**WARNING:** Unauthorised disassembly, reassembly, or internal adjustment may result in a hazardous condition, and will revoke any guarantees.

## 4. GS 2000 RANGE CLASS 1 SOLENOID VALVES

### Dimensions (mm)

DN/TYPE	GEW	SW	A	B	C	H1	H2	H3	H4	X	Y	Z
GS-2011-2120	Rp1/2	36	79	100	72	118	36			15	7	38
GS-2011-2220	Rp1/2	36	79	100	72	118		53		15	7	38
GS-2011-2420	Rp1/2	36	79	100	72	118			105	15	7	38
GS-2011-3120	Rp3/4	36	79	100	72	118	38			15	7	38
GS-2011-3220	Rp3/4	36	79	100	72	118		53		15	7	38
GS-2011-3320	Rp3/4	36	79	100	72	118			105	15	7	38
GS-2011-3420	Rp3/4	36	79	100	72	118			105	15	7	38
GS-2011-4120	Rp 1	46	98	125	72	156	40			15	7	48
GS-2011-4220	Rp 1	46	98	125	72	156		56		15	7	48
GS-2011-4320	Rp 1	46	98	125	72	156			110	15	7	48
GS-2011-4420	Rp 1	46	98	125	72	156			110	15	7	48
GS-2011-5120	Rp 1	65	106	150	85	175	64			15	0	52
GS-2011-5220	Rp 1	65	106	150	85	175		77.5		15	0	52
GS-2011-5320	Rp 1	65	106	150	85	175			110	15	0	52
GS-2011-5420	Rp 1	65	106	150	85	175			110	15	0	52
GS-2011-6120	Rp 2	75	151	180	85	203		92		15	0	69

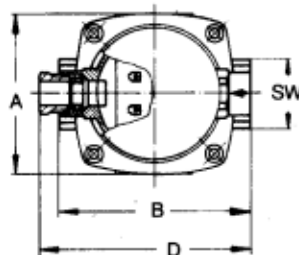
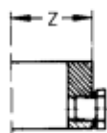
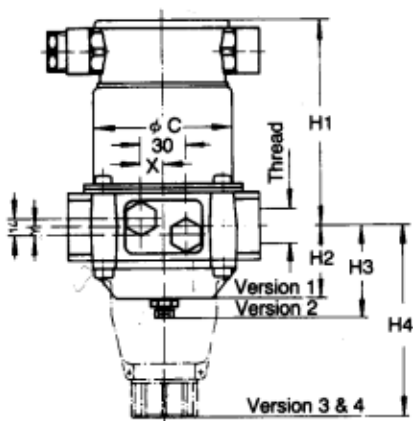

**FOR THREAD SIZES Rp 1/2" TO 1 1/2"**

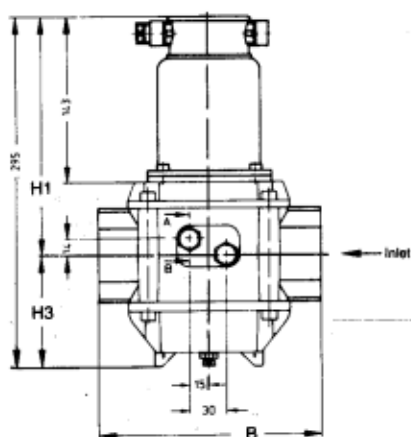

**FOR THREAD SIZE Rp 2"**

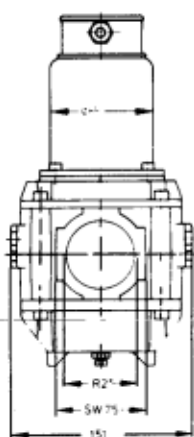
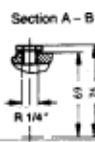

**Gas valve, screwed ends  
RP 2"**

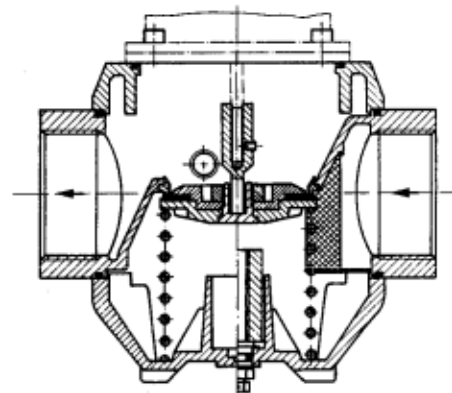

Users are reminded of their responsibility to ensure that all Johnson Controls Products are used in a manner which is safe and in compliance with local laws and regulations and without risks to health and property.

LEAFLET SUBJECT TO CHANGE WITHOUT NOTICE

JOHNSON CONTROLS PRODUCTS GROUP

## SERVICE EXCHANGE ACTUATORS ITT/Johnson, SH Electrohydraulic, & GH 5000 Gas Safely Shutoff Valves

### SERVICE EXCHANGE ACTUATORS For Electrohydraulic Gas Safety Shut-off Valves

**AS OF AUGUST 1996 JOHNSON CONTROLS  
 ARE NO LONGER OFFERING A SERVICE  
 EXCHANGE PROGRAM FOR SH SERIES  
 ACTUATORS**

#### ELECTROHYDRAULIC VALVES

As in the manufacture of any long-term product there is a history of improvement and modification known and recorded within the company. There are major internal differences between the ITT and SH valves and the GH series. Such information is not known to outside companies.

The Johnson Controls class 1 electrohydraulic valves were developed from the ITT range of 'Hydramotors' (registered trade mark). From 1975 changes were made and the range was re-designated the 'SH electrohydraulic valve series', using an alpha numeric numbering system to classify sizes, types, connections and voltages. In order to distinguish the new models from earlier production an international coding system, the GH 5000 series, was introduced for customers of the Johnson Controls worldwide organisation.

Electrohydraulic valves are used in gas burner trains and controls and are essential for the safe operation of the burner in numerous applications including public buildings and facilities, schools and shopping complexes. In these situations safety is of the utmost importance.

#### Non-Repairable Actuators

The very early type HO (ITT)Hydramotors are obsolete and MUST be replaced if they fail.

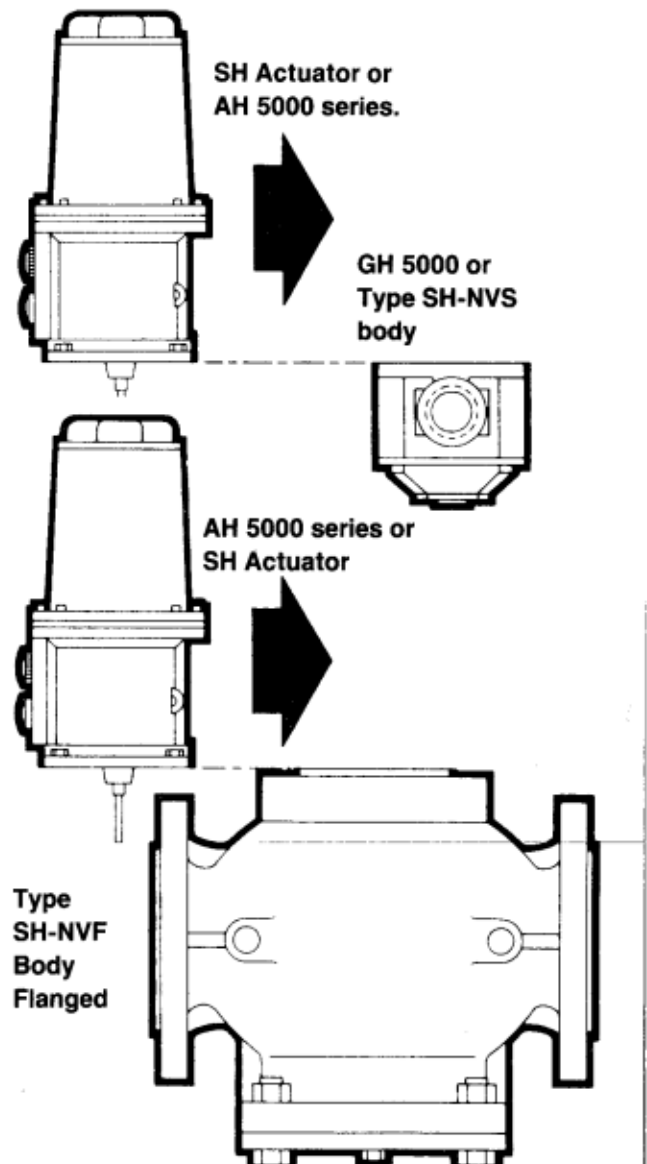

**Type AH Actuator for  
 Series GH & SH Electro  
 hydraulic Gas Safely  
 Shut-Off Valves**

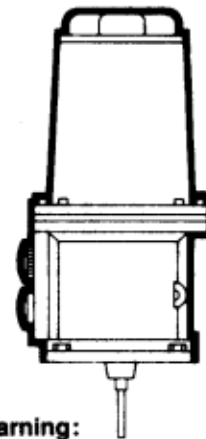

**AH-5000 or  
SH Actuator**

**Warning:**

**It is imperative that the extension  
 piece attached to the actuator stem re-  
 mains with the valve on replacement  
 of the actuator and is used again with  
 the replacement actuator.**

Adjustment of switches in terminal box

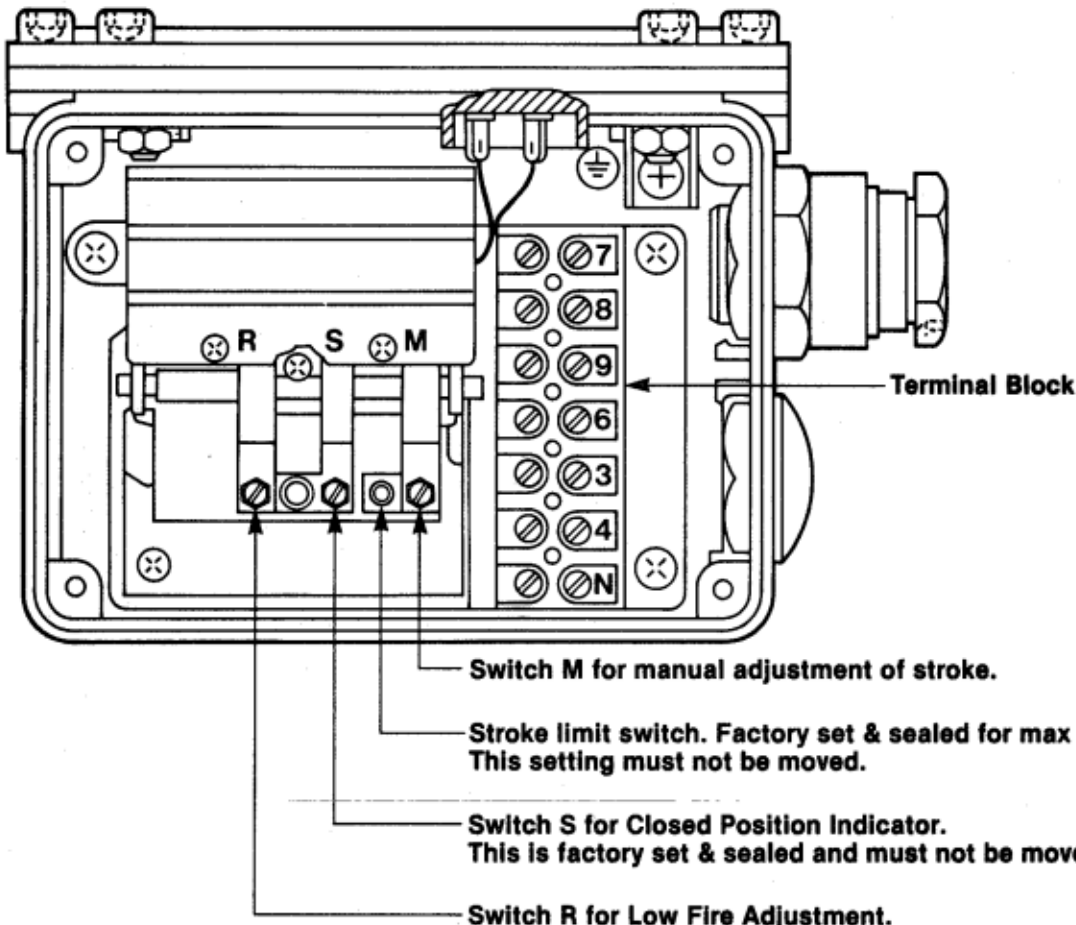

-Note Switch S for Closed Position Indicator. Switch must not  
 indicate 'closed' if the valve plug is more than 1 mm from  
 shut-off condition.

The adjustment of the switches to different switching positions is carried out on the slotted screws.  
 Clockwise turning of the screws (screwing in) effects stroke reduction, counterclockwise turning effects  
 stroke increase. On switch M a smaller or larger flow rate is effected.

Check switch position and flow rate after adjustment by several switching cycles.

## Replacement of Actuator

1. Close main gas cock, disconnect power supply and disconnect cabling.
2. Remove the 4 screws (1) in locking rings (2) and lift off actuator.
3. Clean sealing surfaces of valve and new actuator. Gasket ring (3): On valves with a flat gasket ring—the old ring is removed and a new one used.

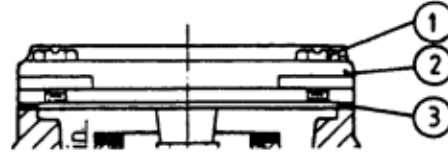

On valves which are sealed with a rubber ring with square □ or circular O cross-section, the gasket is cleaned and re-used.

### ELECTRICAL CONNECTIONS: TYPE AH ACTUATOR FOR GH & SH SERIES VALVES CAUTION!! SH SERIES HAS DIFFERENT TERMINALS (NUMBERS IN BRACKETS)

Operation	Terminal	Terminal Connection	Connection Diagram
On-Off AH-5X00-01X0	6	none (vacant terminal)	
	3	none (vacant terminal)	
	4	On-Off	
	N	Neutral (N)	
HIGH/LOW OFF AH-5X00-03X0	6	none (vacant terminal)	
	3	On-Off	
	4	Low Position	
	N	Neutral (N)	
HIGH/LOW OFF + CPI AH-5X09-04X0	6	none (vacant terminal)	
	3	On-Off	
	4	Low Position	
	N	Neutral (N)	
AH-5X09-04X0	7	Opening contact	
	8	Closing contact	
	9	common connection	
ON/OFF + CPI AH-5X09-06X0	6	none (vacant terminal)	
	3	none (vacant terminal)	
	4	On-Off	
	N	Neutral (N)	
AH-5X09-06X0	7	Opening contact	
	8	Closing contact	
	9	common connection	

### 1 CLOSED POSITION INDICATION

The On/Off and High/Low/Off versions of the GH/SH/AH range of electro-hydraulic valves can be fitted with Closed Position indication (C.P.I.) C.P.I. switches are set and sealed after complying with the strict requirements set out in Appendix 2 of MRST 2.3/2.4

Safety shut-off valves can be a more economical method of meeting the requirements agreed by British Gas, SBGI and BCEMA and as set out in BS 5885: 1980 which state that "for burners above 1000 KW and up to 2000 KW two Class One Valves with systems check are required" Acceptable systems check, in accordance with this document can be either:

- (a) Safety Shut-Off Valve with proof of closure switch:
  - OR (b) Safety Shut-Off Valve fitted with C.P.I. OR (c) Pressure proving system.
- Of these alternatives, the most economical method is generally (b), Safety Shut-Off Valves fitted with C.P.I. which can thus give economies at the burner manufacturing stage.

**List of Johnson Controls**

**Electrohydraulic Actuators**

The Actuators listed below are all products of Johnson Controls (or formerly ITT controls).

List of HO (ITT) Hydramotor, SH & GH 5000 Actuators:

Actuators 240 volt	Actuators 220 volt	Actuators 110 volt
HO (ITT)	HO (ITT)	HO (ITT)
SH 111	SH 110	SH 112
SH 131	SH 130	SH 132
SH 141C	SH140C	SH 142C
SH 161C	SH 160C	SH 162C
SH 211	SH 210	SH 212
SH 231	SH 230	SH 232
SH 241	SH 240C	SH 242C
SH 261C	SH 260C	SH 262C
SH 411	SH 410	SH 412
SH 431	SH 430	SH 432
SH 441C	SH 440C	SH 442C
SH461C	SH460C	SH462C
AH-5100-0120	AH-5100-0110	AH-5100-0130
AH-5100-0320	AH-5100-0310	AH-5100-0330
AH-5109-0420	AH-5109-0430	AH-5109-0430
AH-5109-0620	AH-5109-0610	AH-5109-0630
AH-5200-0120	AH-5200-0110	AH-5200-0130
AH-5200-0320	AH-5200-0310	AH-5200-0330
AH-5209-0420	AH-5209-0410	AH-5209-0430
AH-5209-0620	AH-5209-0610	AH-5209-0630
AH-5400-0120	AH-5400-0110	AH-5400-0130
AH-5400-0320	AH-5400-0310	AH-5400-0330
AH-5409-0420	AH-5409-0410	AH-5409-0430
AH-5409-0620	AH-5409-0610	AH-5409-0630

**New GH Electrohydraulic Valves**

**Features:**

- CPI switching now available over entire range.

IP54 rating over entire range (protected against dust ingress and water sprayed from all directions).

Improved flow.

Wire mesh integral filters.

Safety shut-off.

Class 1, certified to BS5963

Robust construction.

Interchangeable actuators

240, 220 & 110V 50/60Hz models available.



Type GH Valve up to 2" Threaded.  
Aluminium Die Cast Body.



Type GH Valves 2½" sizes and larger

When fitting a service exchange actuator to a valve body **users should refer** to the service/installation leaflet.