

Gas Pressure Regulator Series 270 MK2

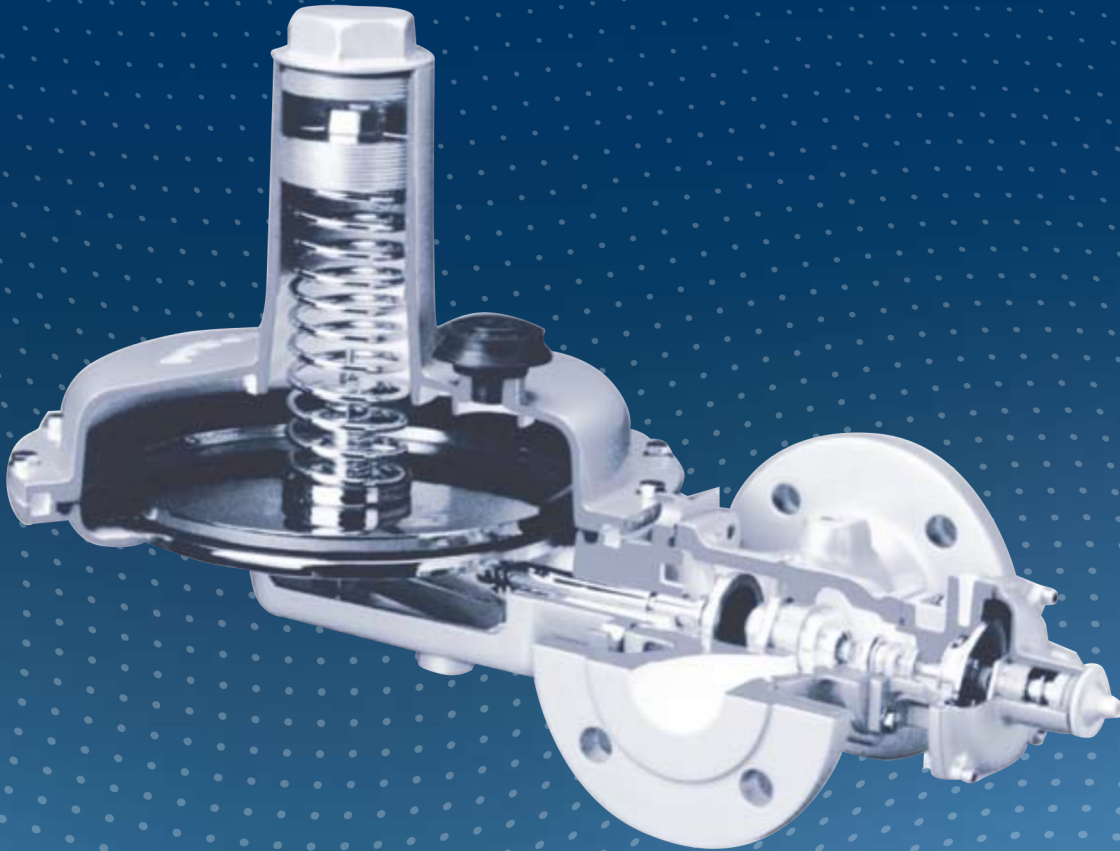

PRODUCT INFORMATION

**Serving the Gas Industry
Worldwide**



CONTROLS SUPPLY CHAIN
VALVES ACTUATORS INSTRUMENTATIONS



GAS PRESSURE REGULATOR SERIES 270 MK2

Introduction, Application, Features & Technical Data

Introduction

- The Series 270 MK2 regulator is a direct acting, single diaphragm, spring loaded open, lever operated regulator for use on gas pressure reduction systems.
- Control of varying inlet pressure and capacity applications is ensured by utilising a range of interchangeable orifices of varying size.
- Use with confidence on natural and manufactured gases of non-aggressive nature, including Nitrogen, Carbon Dioxide, Propane and Butane.

Application

- Designed for use on gas pressure reduction services to domestic, business premises and small industrial feeds to burners, heater units, boilers and other items of equipment where an accurate, safe and dependable pressure controlled supply is required.

Features

- Completely independent operation of regulator and safety cut-off valve.
- Diaphragm casing can be rotated through 360° at intervals of 45° to assist servicing and installation in confined spaces.
- Both regulator casing/valve head and safety cut-off valve can be removed from the body as cartridges, ensuring straightforward maintenance without removing the body from the pipeline.
- Wide operational pressure range.
- Internally or Externally impulsed (ICL/ECL).

SERVICE CONDITIONS	
Maximum Inlet Pressure (dependent upon orifice size fitted)	Up to 10.3 bar g (150psig)
Outlet Pressure Range: Series 270 MK2 Series 270H MK2	10 to 350 mbar g (4 to 140" wg) 320 to 500 mbar (128 to 200" wg)
Maximum Incidental Outlet Pressure	700 mbar g (280" wg) (Max. Allowance OPCO trip set pressure)
Minimum Differential Pressure	Typically 35 mbar (14" wg)
Internal Relief Valve Setting: Series 270 Series 270H	Nominally 20 mbar g (8" wg) 80 mbar g (32" wg) (above regulator outlet pressure set point)
Temperature Range	-20°C to +60°C

Size Range

- 1.1/2" and 2" Screwed BS21 Rc & Rp
- DN 50 Flanged to PN16 :
BS EN 1092-2:1997
ASA Class 150

Options

- P - Type : No Internal Relief
- R - Type : With Internal Relief
- ECL : External Control Line
- ICL : Internal Control Line
- Regulator can be fitted with the Series 309 Over pressure (OPCO) or combined Under/Over pressure (UPCO/OPCO) Safety Cut-Off valve. These devices protect the downstream system in the event that a dangerous gas pressure condition develops.

Installation

The regulator may be mounted in any orientation to suit site conditions, moisture or debris must not ingress the vent hole. For optimum performance the recommended operating position is with diaphragm casing horizontal and spring housing pointing vertically upwards.

It is important when installing equipment that pipeline stresses are kept to a minimum and no undue external forces are placed on the connections.



SPRING SELECTION - REGULATOR SPRING RANGES			
Spring		Outlet Pressure Range	
Number	Colour	mbar	ins wg
1244	Red	10 - 15	4 - 6
1245	Grey	15 - 20	6 - 8
1299	Purple	18 - 35	7 - 14
1246	Green	20 - 28	8 - 11
1247	Yellow	28 - 45	11 - 18
1248	Black	45 - 75	18 - 30
1249	White	75 - 110	30 - 44
1250	Orange	95 - 150	38 - 60
1251	Blue	140 - 225	56 - 90
1252	Silver	200 - 350	80 - 140
1263*	Brown	320 - 500	128 - 200
1253	OPCO Setting Spring for fitting into main regulator		

*Series 270H model only, requires special adjuster

OPCO: SAFETY CUT-OFF VALVE			
Spring		Cut-Off Range	
Number	Colour	mbar	ins wg
861	Brown	35 - 90	14 - 36
1103	Gold	80 - 130	32 - 52
1104	Purple	120 - 250	48 - 100
1105	Black	200 - 350	80 - 140
1254*	Red	340 - 500	136 - 200
1255*	Green	450 - 600	180 - 240

* Requires special spacer

S.309LP UPCO/OPCO SAFETY CUT-OFF VALVE				
	Spring		Cut-Off Range	
	Number	Colour	mbar	ins wg
OPCO	1109	Grey	40 - 55	16 - 22
	1110	Green	50 - 110	20 - 40
	1111	Silver	110 - 200	44 - 80
	1140	Silver/Red	150 - 240	60 - 96
UPCO	1138	Blue/Green	10 - 30	4 - 12

Minimum OPCO & UPCO/OPCO Settings

- P - Type: 35 mbar (14" wg) or 10% above regulator set point, whichever is the higher
- R - Type: 55 mbar (22" wg) when Internal relief fitted
- Minimum differential pressure between UPCO and OPCO is 45 mbar (18" wg) and 65 mbar (26" wg) with Internal relief

Note: The Series 309 MP2 Overpressure Cut-Off Valve can be fitted on special request to give a maximum trip pressure of 700mbar (280" wg) - contact BD-RMG for details.

MATERIALS OF CONSTRUCTION	
Regulator	
Body	Ductile Iron: BS EN 1563 Grade EN - GJS - 400 - 18-LT
Top & Bottom half casing Top cap, Spring adjuster	Aluminium Alloy : BS.1490 Grade LM24M
Orifice & Bottom casing guide bush	Brass: BS.2874 Grade CZ 121
Lever	Stainless Steel: BS.3416 Grade ANC 3B
Valve Spindle	Stainless Steel: BS.970 Grade 416S29
Spring retainer and Diaphragm plates	Mild Steel: BS.1449 Grade CS4
Relief Valve and Main springs	Spring Carbon Steel: BS.5216 Grade HS3 and Chrome Vanadium: BS2803
Valve Seat & 'O' rings	Nitrile
Diaphragm	Moulded Nylon Reinforced Nitrile
Safety Cut-Off Valve	
Body	Aluminium: BS.1490 LM6
Spindle	Stainless Steel: BS.970 Grade 316 S31
Valve	Aluminium: BS.1474 Grade 6082TF
Valve seating	Polyurethane
Diaphragm & 'O' rings	Nitrile
Spring Adjuster	Brass: BS.2874 Grade CZ 121
Spring	Spring Carbon Steel: BS.5216 Grade HS3

ORIFICE SELECTION		
Orifice Size	Maximum Inlet Pressure	
	mm	bar
5	10.3	150
10	10.3	150
15	5	72
20	4	60
25	2	30
32	1	15



GAS PRESSURE REGULATOR SERIES 270 MK2

Performance

TABLES OF COEFFICIENTS				
Orifice Size (mm)	Body size	Cg	K1	C1
5	1.1/2" Sc.	29	139	24
	2" Sc./DN 50 FL	31	131	26
7.5	1.1/2" Sc.	72	123	28
	2" Sc./DN 50 FL	73	118	29
10	1.1/2" Sc.	112	127	28
	2" Sc./DN 50 FL	125	110	31
15	1.1/2" Sc.	282	100	31
	2" Sc./DN 50 FL	294	105	32.5
20	1.1/2" Sc.	462	91	37
	2" Sc./DN 50 FL	495	87	39.5
25	1.1/2" Sc.	607	91	36
	2" Sc./DN 50 FL	686	85	40
32	1.1/2" Sc.	692	94	35.5
	2" Sc./DN 50 FL	809	83	41

Capacity Performance

For in-control capacities see capacity graphs:
Maximum full open capacities can be calculated using the following equations:

Sub-Critical Flow

$$\blacktriangleright (P_e - P_a) \leq 0.5(P_e + P_b)$$

$$Q = \frac{6.97}{\sqrt{d(te + 273)}} C_g(P_e + P_b) \sin \left[K_1 \sqrt{\frac{P_e - P_a}{P_e + P_b}} \right] \text{ deg}$$

Critical Flow

$$\blacktriangleright (P_e - P_a) \leq 0.5(P_e + P_b)$$

$$Q = \frac{6.97}{\sqrt{d(te + 273)}} C_g(P_e + P_b)$$

Example Calculation: For 2" size with 15mm orifice

Conditions : Inlet Pressure (Pe) 1 barg
 : Outlet Pressure (Pa) 200 mbarg
Medium : Natural Gas SG= 0.6

$$\text{Test for flow conditions: } (1 - 0.2) \leq 0.5(1 + 1.01325) \\ 0.8 \leq 1.006$$

*Hence Sub-Critical Flow conditions.

Full Open Capacity:

$$Q = \frac{6.97}{\sqrt{0.6(15 + 273)}} \times 294(2.01325) \sin \left[105 \sqrt{\frac{0.8}{2.1325}} \right] \text{ deg}$$

$$Q = 287 \text{ Sm}^3/\text{hr}$$

PERFORMANCE CLASSIFICATION

Lock Up: The amount of 'Lock Up' pressure is dependent upon the prevailing pressure ranges and orifice size.

Regulator 'Lock Up' pressure:
5 to 10 mbar (2 to 4" wg)

Accuracy Class:
All graphical data based on AC 20

Flow Turn Down Ratio:
Varies according to orifice size, prevailing pressure, flow and installation design.
For a general guide expect 50:1 minimum.

DEFINITION

Q = Full Open Capacity in m³/hr at Metric Standard Conditions (MSC)

Cg = Flow Coefficient

K1 = Body Shape Factor

d = Relative Density/SG of Gas (Air = 1)

Pe = Inlet Pressure (bar g)

Pa = Outlet Pressure (bar g)

Pb = Ambient atmospheric pressure in bar Absolute

te = Gas temperature at inlet of unit in °C

6.97 = Contant

MSC = Absolute pressure of 1.01325 barA and temperature of 15°C



GAS PRESSURE REGULATOR SERIES 270 MK2

Capacities: DN 50 in sm^3/hr for Natural Gas (SG 0.6)

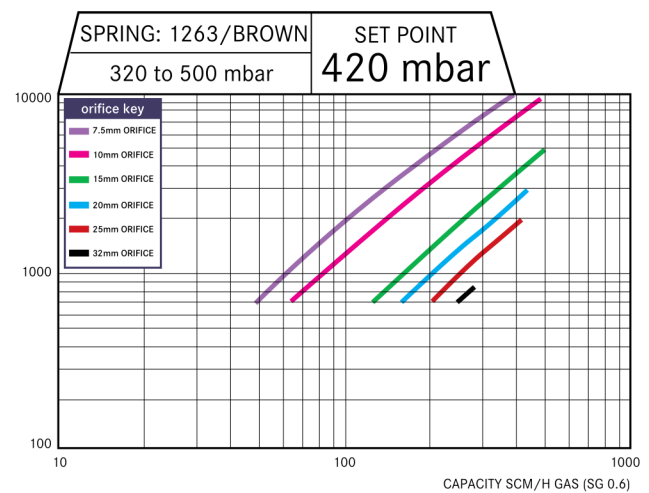
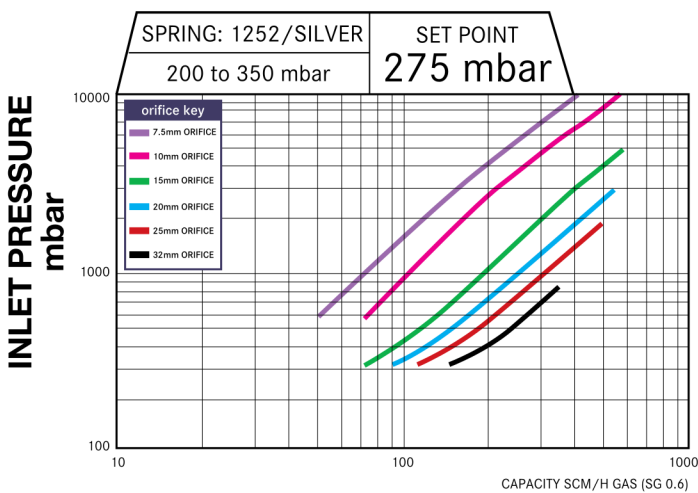
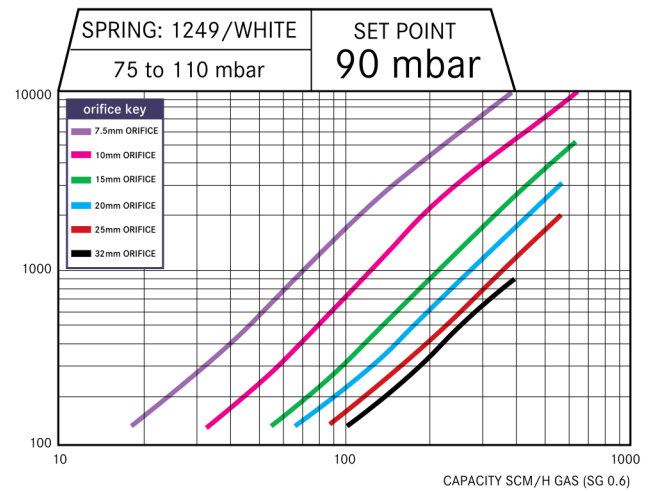
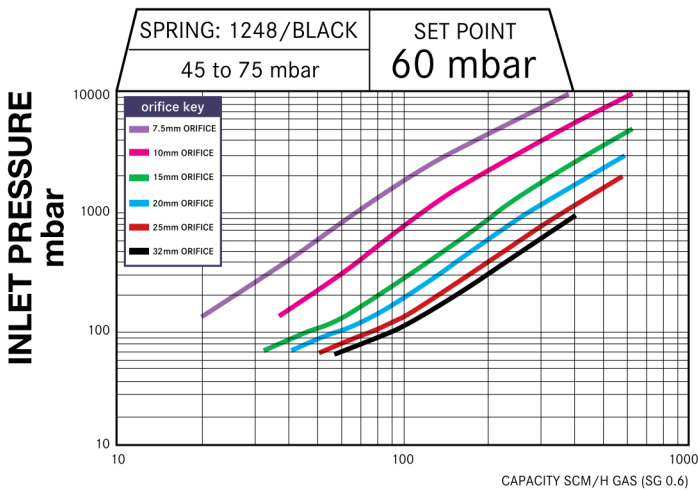
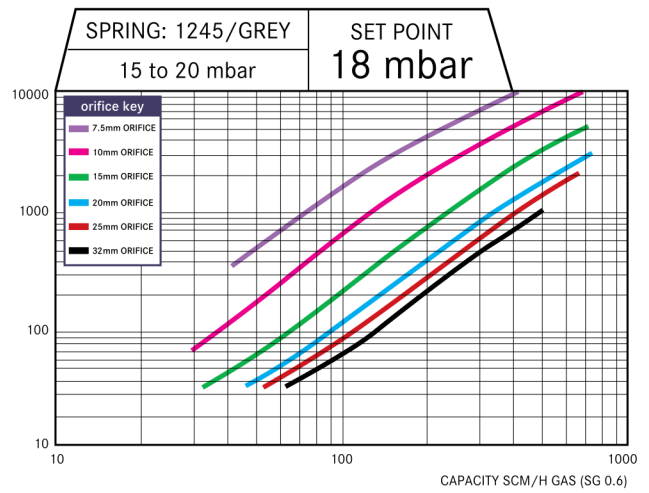
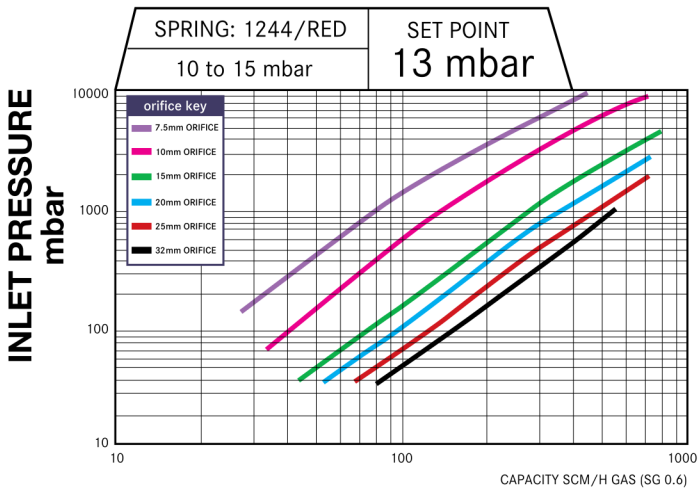

Graphs give capacities for internally/externally impulsed and with or without OPCO (refer to correction factors for 40mm (1 1/2") size unit)



GAS PRESSURE REGULATOR SERIES 270 MK2

Capacities: DN 50 in sm^3/hr for Natural Gas (SG 0.6)

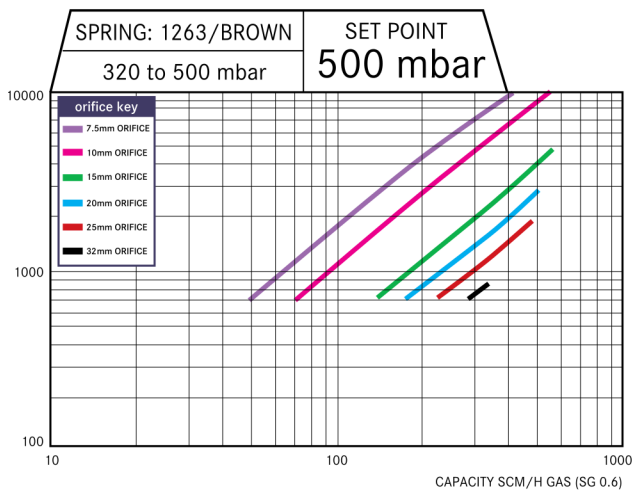
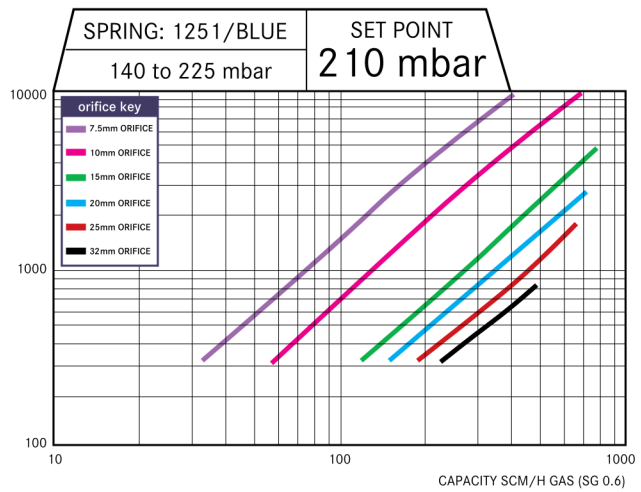
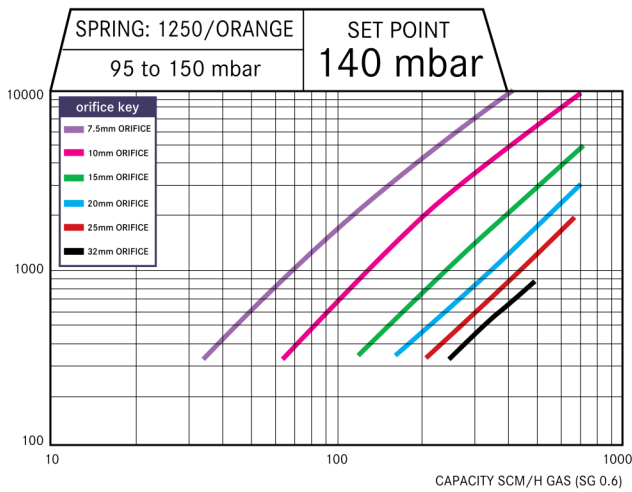
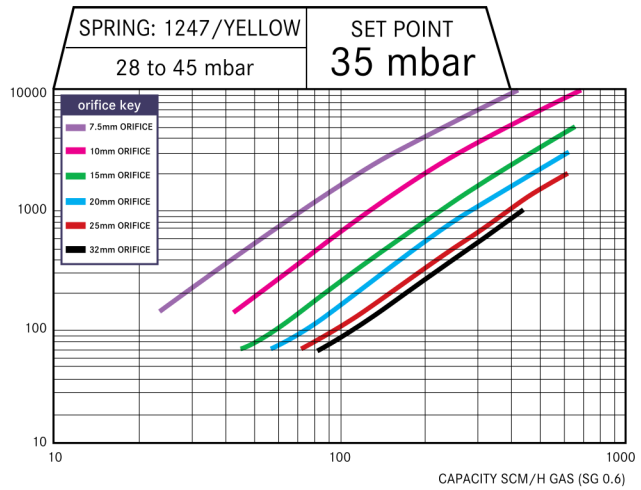
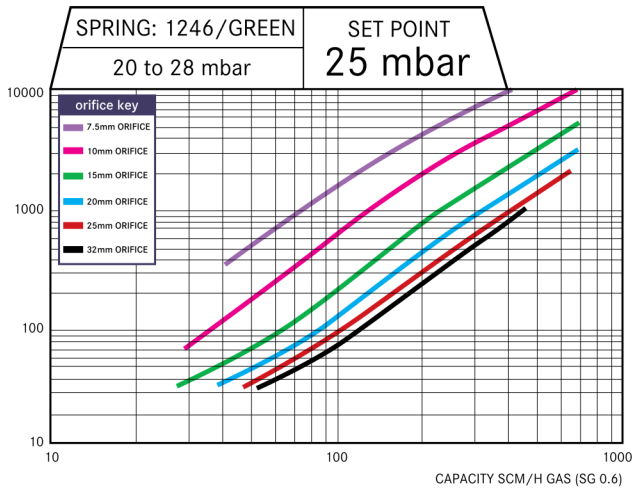

Correction Factors

40mm (1.1/2") screwed

For calculating the capacity of the 40mm (1.1/2") size unit, obtain the flow capacity from the graphs and multiply by the following correction factors:

Orifice Size	Correction Factor
32mm	0.8
25mm	0.9
All other sizes	1.0

Sm^3/hr to SCFH: x 35.3

Types of Gases:

The capacities shown in the tables are given in terms of natural gas SG 0.6. For all other gases multiply by the following correction factor:

$$\sqrt{\frac{0.6}{\text{SG of gas handled}}}$$

Droop: 20%



GAS PRESSURE REGULATOR SERIES 270 MK2

Sectional Arrangement (Series 270 -OPCO-ICL)

NON-PRINT AREA

7

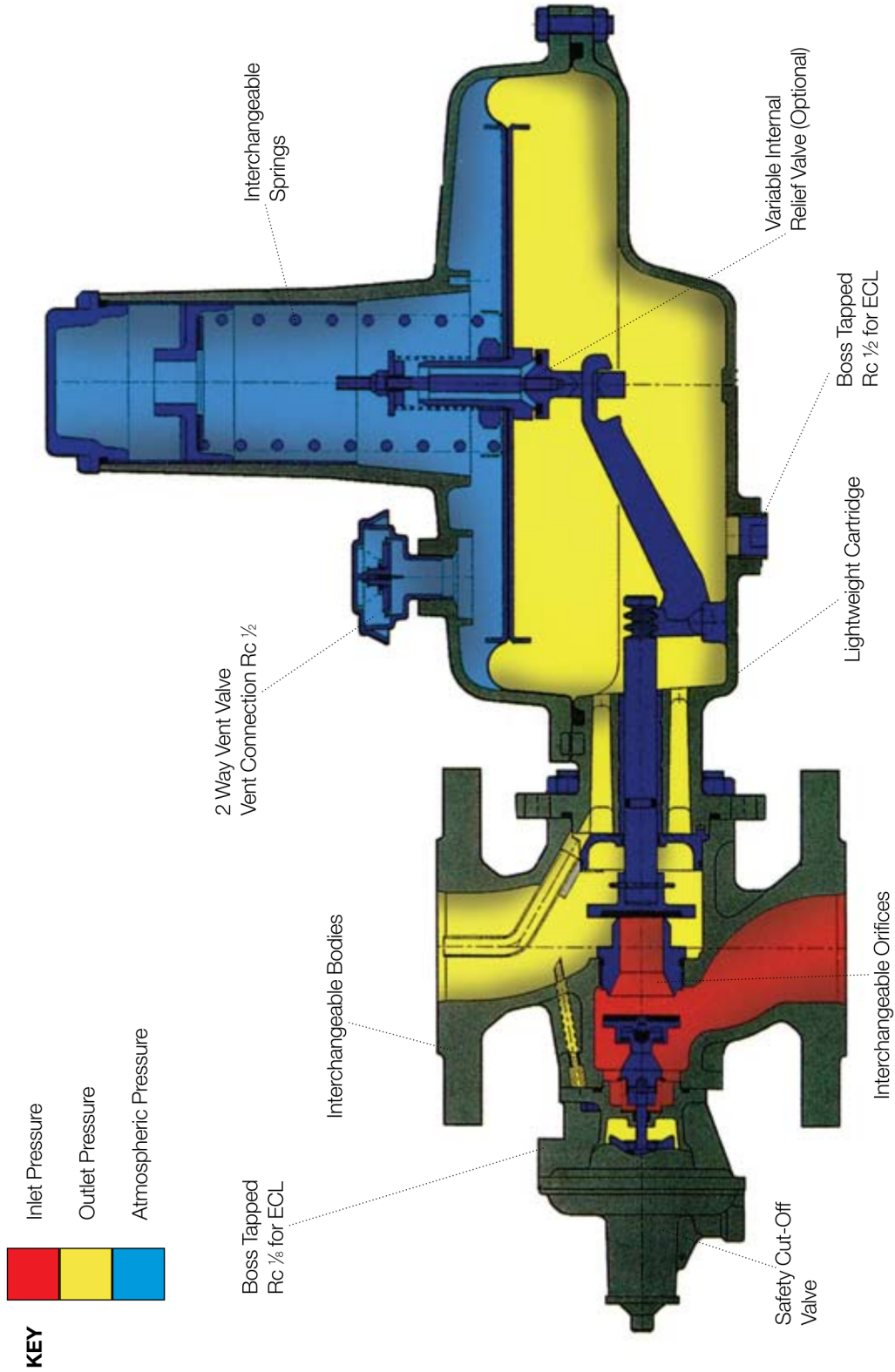



GAS PRESSURE REGULATOR SERIES 270 MK2

Dimensions & Weights

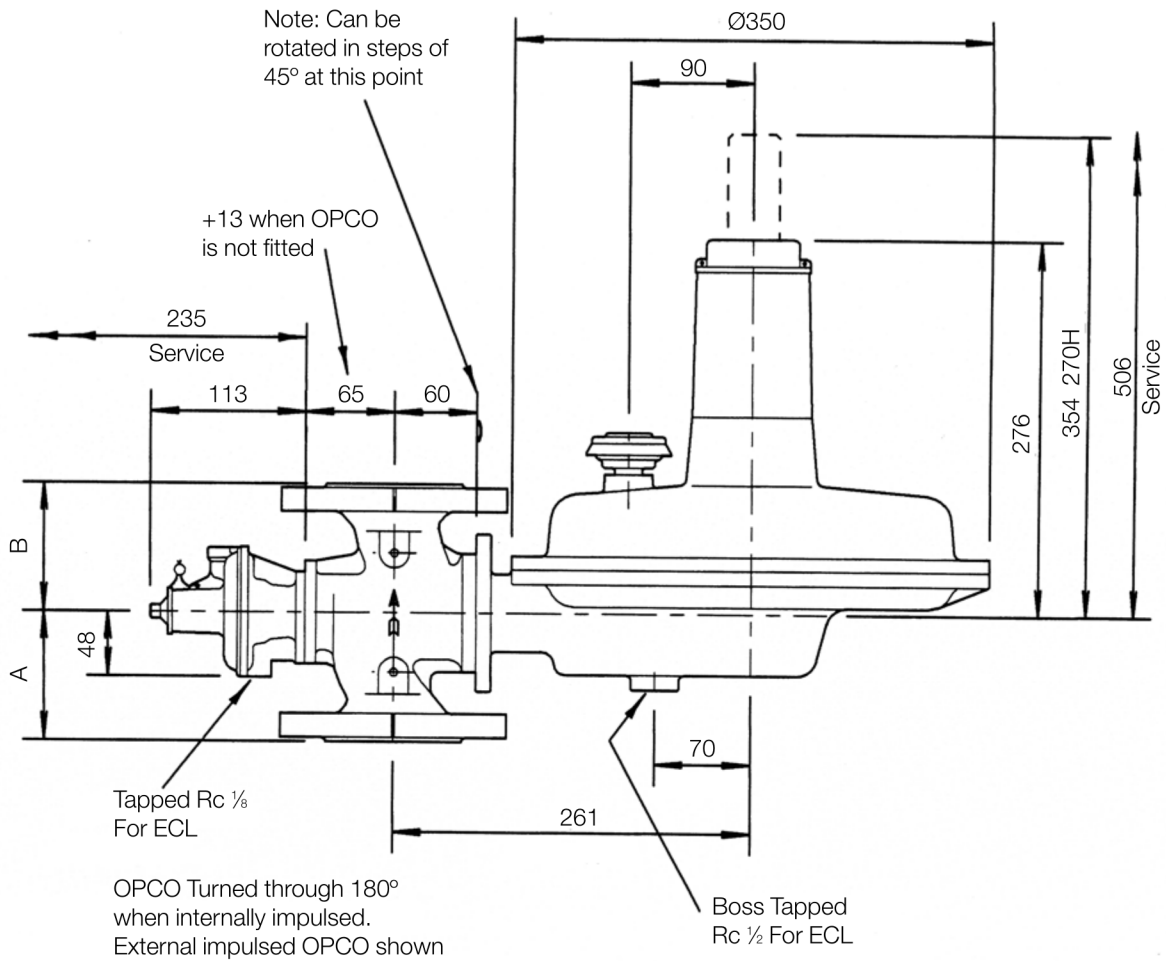

DIMENSIONS AND WEIGHTS						
Size			270		270H	
	A	B	Wt with OPCO	Wt No OPCO	Wt with OPCO	Wt No OPCO
	mm	mm	Kg	Kg	Kg	Kg
1.1/2" Screwed	73	95	12.5	12	13.5	13
2" Screwed	73	95	12.5	12	13.5	13
DN 50 Flanged	95	95	16.5	16	17.5	17



Internal Relief

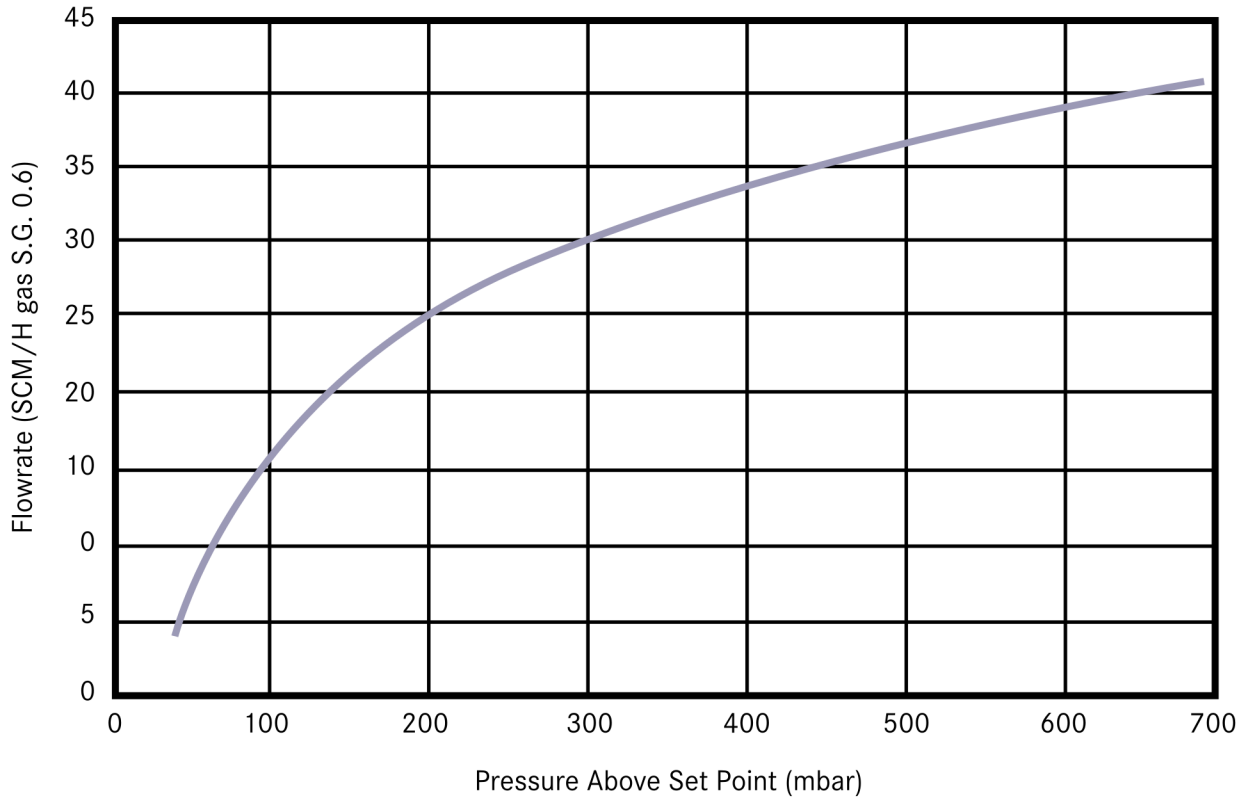

9

Typical Installation

