



H10 Hydramotor® Actuator

Travel Limit, Pull-Type

INSTALLATION AND SERVICE

SDI: H10-3
Effective: 12-96
Supersedes: 6-88



DESCRIPTION

Hydramotor® valves consist of three components: the actuator described in this sheet (Figure 1) together with a mounting yoke and a valve body.

H10 hydraulic actuators pull when energized and extend, powered by an internal return spring, when deenergized, providing ON-OFF control of valves. The operating mechanism is completely immersed in oil, eliminating usual maintenance and service.

OPERATION (See Figure 2)

When the actuator terminals are powered, relief valves close and an electric motor-driven pump applies hydraulic pressure to a spring-loaded piston. When the stem reaches full travel, a limit switch opens the pump motor circuit. The relief valves remain closed, holding the stem in its extended position until the actuator is deenergized, opening the relief valves and allowing the internal return spring to retract the piston. Deenergizing the actuator opens the normally-open relief valves. NOTE: When the actuator is held in its energized position, the motor may restart intermittently to maintain proper pressure against the piston.)

INSTALLATION

CAUTION

- This actuator should be installed and/or serviced by trained and experienced service technicians.
- Turn off electric power supply before wiring actuator to prevent electrical shock and damage to equipment.
- All wiring must conform to applicable electrical codes and ordinances (NEC Class 1).
- Limit controls must be capable of handling electrical load shown on actuator nameplate (volts, frequency). Wire limit controls in hot side of circuit. Do not connect additional wiring to limit switch.
- Maximum connected load of motor and auxiliary switch must not exceed 2000 VA.
- Ensure actuator selected is appropriate for the application.
- Actuators used in areas where dust, corrosive or explosive elements are present should be equipped with proper protective shields. Protective shields must be replaced before operating valve.
- It is recommended that actuator surface temperature be kept below 175° F (80°C).
- Check application for proper voltage. A 60 cycle actuator is suitable for 50 cycle operation but power stroke timing will increase by approximately 20%.

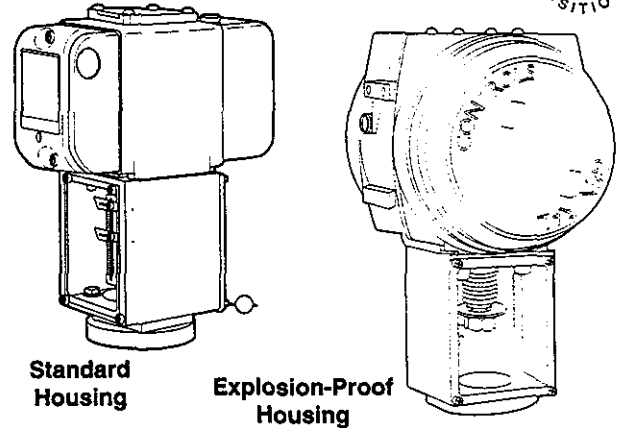

Figure 1. H10 Hydramotor® with Mounting Yoke

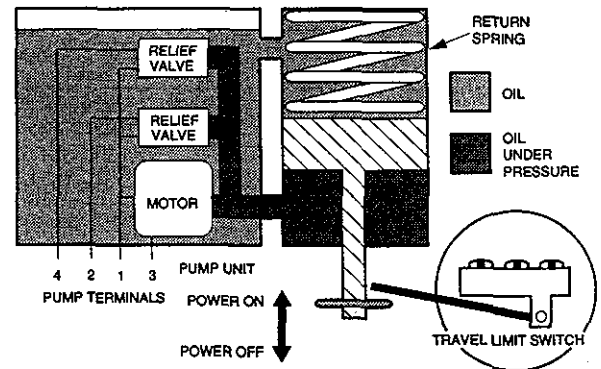

Figure 2. Typical H10 Operation

1. Follow equipment manufacturer's wiring instructions. Typical wiring connections are shown in Figures 3 and 4.
2. Check power source, actuator and all operating and limit switches in electrical circuit for proper operation.

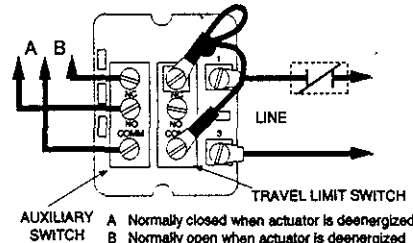
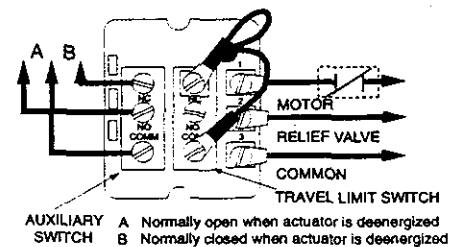

Figure 3.
Two-Wire
Circuit with
Auxiliary
Switch Wiring

Figure 4.
Three-Wire
Circuit with
Auxiliary
Switch Wiring



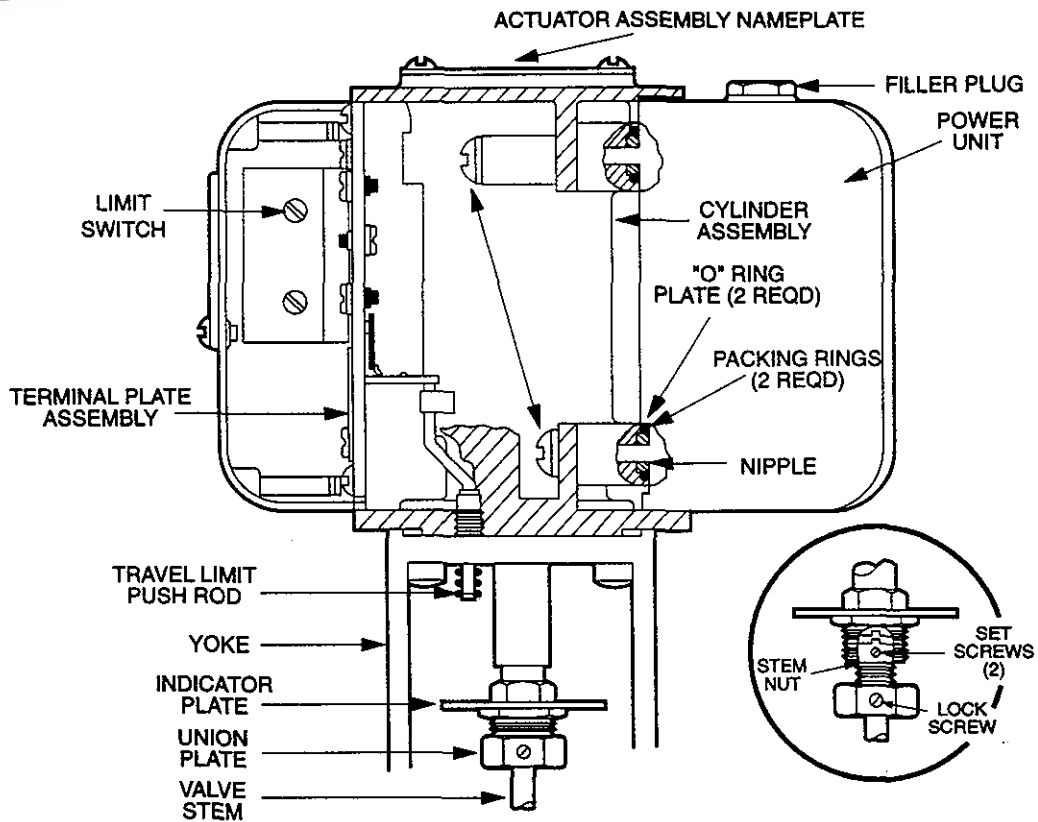

Figure 5. H10 Cross Section

ACTUATOR REPLACEMENT

Removal

1. Loosen lock screw, unscrew union nut to detach valve stem from actuator shaft (see Figures 5 and 6).

CAUTION

Do not damage the polished surfaces of valve stem or actuator shaft.

2. Energize actuator to relieve pressure of closing spring.
3. Remove mounting bolts or bushing nut, depending on type of mounting, holding yoke to valve body.
4. Deenergize actuator and lift off of valve body.

Replacement

Replace actuator with unit having identical catalog number. Reassembly is the reverse of disassembly:

1. Energize new actuator.
2. Secure actuator to valve.
3. Line up prongs of stem head nut with slot in actuator shaft.
4. Deenergize actuator.
5. Be sure prongs are in slot.
6. Tighten union nut fingertight.
7. Tighten lock screw to 25 in-lb.
8. Test for proper operation.

STEM NUT ADJUSTMENT (See Figure 6)

CAUTION

If stem nut is not adjusted properly, valve assembly may malfunction.

NOTE: If stem nut is removed during repair, it must be adjusted according to the following procedure.

1. For proper seating pressure and correct valve lift, distance from bottom of actuator shaft to top of stem nut must be measured, as shown in Figure 6 (refer to valve installation instructions). The "lift" dimension is measured with valve stem in DOWN position (closed) and actuator shaft in UP (energized) position. [Refer to valve installation instructions for "lift" dimension.]

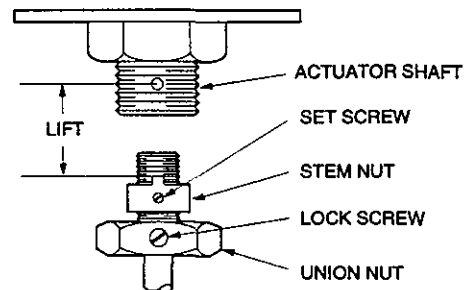

Figure 6. Stem Nut Adjustment

2. Adjust upper stem nut (see Table 1) and lock with set screws. Rotate stem to align prongs with grooves.



CAUTION

If stem nut is not adjusted properly, valve assembly may malfunction.

NOTE: If stem nut is removed during repair, it must be adjusted according to the following procedure.

1. For proper seating pressure and correct valve lift, distance from bottom of actuator shaft to top of stem nut must be measured, as shown in Figure 6 (refer to valve installation instructions). The "lift" dimension is measured with valve stem in DOWN position (closed) and actuator shaft in UP (energized) position. [Refer to valve installation instructions for "lift" dimension.]

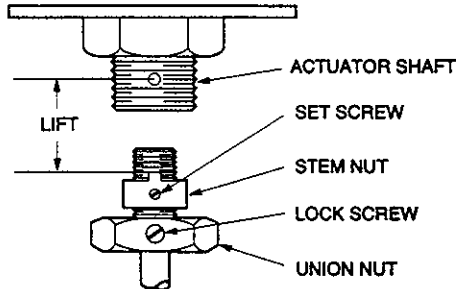

Figure 6. Stem Nut Adjustment

2. Adjust upper stem nut and lock with set screws. Rotate stem to align prongs with grooves.

TERMINAL PLATE REMOVAL/REPLACEMENT (Figure 7)

NOTE: To replace the power unit, the terminal plate must be removed to gain access to power unit mounting bolts.

1. Turn off all electrical power to actuator.
2. Remove covers. Remove two terminal plate screws. Lift plate away from frame.

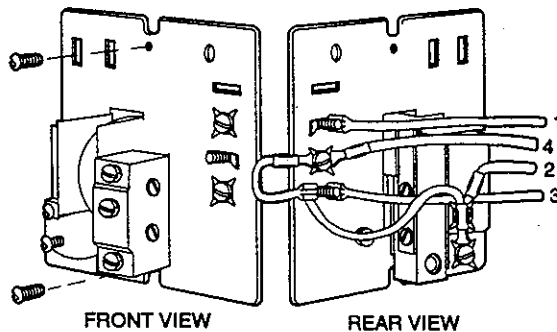
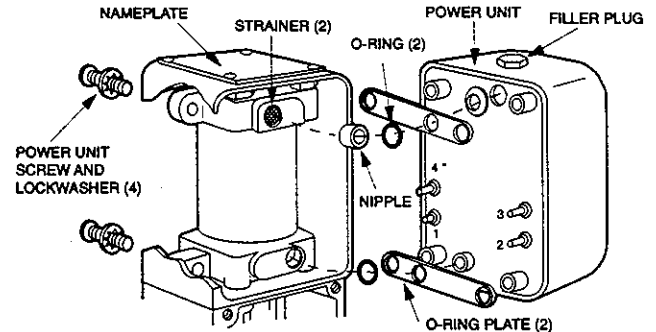

Figure 7. H10 Terminal Plate with Limit and Auxiliary Switches

3. Note the proper position of leads between terminal plate and power unit. Tag leads if necessary to identify for reassembly. Pull lead clips from power unit.
4. Proceed with power unit removal if necessary.
5. When installing terminal plate, insert leads of terminal plate on proper terminals of power unit. Position terminal plate in frame using a gentle downward motion. *Be sure switch actuating lever is on top of limit push rod.*

POWER UNIT REMOVAL/REPLACEMENT

1. Remove terminal plate, as described above. Remove four screws holding power unit to frame (figure 8) and pull power unit straight away, noting position of O-rings.
2. Put new O-rings in place. Position new power unit to frame carefully to prevent damage to O-rings.
3. Replace bolts holding power unit; tighten to 70±10 in-lb.
4. Connect clips on leads to power unit.
5. Replace terminal plate carefully (see above). When installing terminal plate, insert leads of terminal plate on proper terminals of power unit. Position terminal plate in frame using a gentle downward motion. *Be sure switch actuating lever is on top of limit push rod.*



* NOT APPLICABLE TO 3-TERMINAL PUMPS

Figure 8. Exploded View of H10 (Covers Removed)

VALVE SEAL OVERTRAVEL INTERLOCK SWITCH

Actuators with F26, F27 or F28 in the catalog number are equipped with a yoke-mounted valve seal overtravel interlock switch (FM proof-of closure). This switch permits supervision of the valve's closed position and must be used with valve bodies provided with overtravel seal. Refer to separate proof-of-closure installation and service sheet (SDI FM H10/H30-1).

YOKE-MOUNTED AUXILIARY SWITCH KIT

Two yoke-mounted auxiliary switch units, each with up to 3 SPDT independently adjustable switches may be installed.

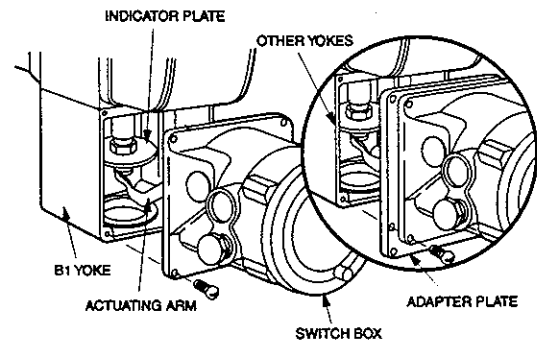
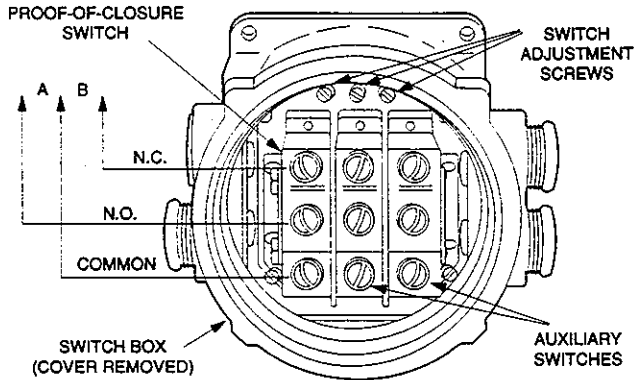

Figure 9. Yoke-Mounted Auxiliary Switch Kit

Installation: The auxiliary switch unit (Figure 9) is supplied with necessary hardware for installation – screws and adapter plate (if necessary) and replaces the dust shield where applicable. Mount adapter plate to yoke and auxiliary switch unit to adapter plate with self-tapping screws. Actuating arm tip must be under actuator stem indicator plate.



Adjustment (Figure 10): Each switch in auxiliary switch unit may be adjusted separately to actuate at any point of actuator stem travel. Turn individual switch adjustment screw counterclockwise to actuate switch closer to deenergized position. Turn screw only 1/8-turn at a time and check operation. Do not attempt to set switch for operation within 1/8" of either end of stroke.



A – N.O. when actuator deenergized
B – N.C. when actuator deenergized

Figure 10. Auxiliary Switch Adjustment

FILLING REPLACEMENT POWER UNIT WITH OIL

Standard units are filled with MIL-H-5606 oil. Units with F5 in catalog number, for low ambient temperature use, are filled with Dow-Corning DC560 silicone oil. Either oil is available from ASCO General Controls and most industrial suppliers.

CAUTION

Do not mix MIL-H-5606 oil with DC560 oils. Oil must be filtered if secured from a source other than ASCO General Controls. Take care that dirt, dust or lint does not enter pump unit or cylinder.

One pint of ASCO General Controls MIL-H-5606 oil is included with each replacement power unit assembly.

1. Unscrew filler plug from oil port at top of unit (Figures 5 and 8).
2. Fill power unit with oil, not to exceed one pint. Power actuator ON and OFF for 15 minutes to release air from cylinder and bring oil temperature to 68° F (20° C) or above. Add enough oil to fill reservoir to within 1/4" of base of filler port.
3. Replace plug and tighten.

ACTUATOR ADJUSTMENT

Certain actuators are equipped with adjustment screw located on the power unit, opposite the terminal plate (Figure 11).

NOTE: If the actuator is on a valve plumbed in an active system, you may choose to close the shutoff valve before performing steps 1 through 4. If so, follow step 4 by opening the shutoff valve and check the valve under normal usage.

1. Deenergize the actuator.
2. Remove the hex cap screw.
3. Turn the screw only 1/2 turn at a time. Turn the screw clockwise to obtain a faster power stroke or turn it counterclockwise for a slower power stroke.
4. Energize the actuator and check the speed after each adjustment. Adjust until the desired speed is obtained.

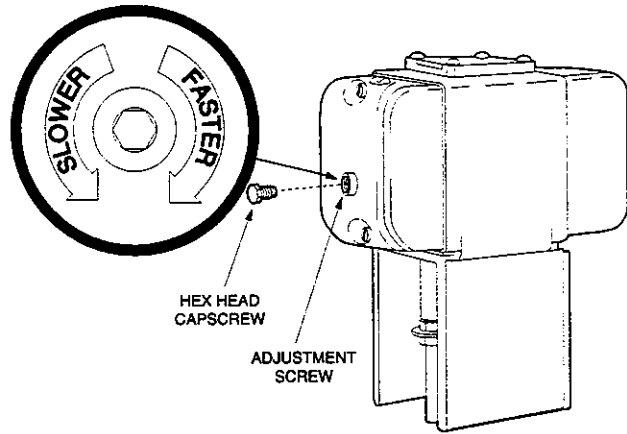

Figure 11. Actuator Adjustment

NOTE. If the adjustment screw is turned to full clockwise or counter clockwise, the position valve will not operate.

REPLACEMENT PARTS ORDERING PROCEDURE

When ordering replacement or spare parts, specify the item number together with its name, the actuator catalog number serial number, and voltage, as shown on actuator nameplate. Specify the number of switches, and whether standard or explosion/weatherproof housing is desired. For a parts list, request SDP H10/H11-1.

NOTE: Stem nut and stem nut set screws are part of the valve body. When ordering parts for valve assembly, consult factory or see valve parts list.

**Table 1. Parts Common to Power Unit Kits
(May be ordered separately)**

Description	No. Reqd.	Part No.
Strainers *	2	50751A
Nipple *	1	15358A
O-Ring Plates *	2	18764A
Power Unit Screws *	2	101957-416-12
Power Unit Screws *	2	2754-416A24Z
Lockwashers *	4	3090-416LZ
O-Rings *	2	16606A56-7
Oil (pint, MIL-H-5606) *	1	S156202A
Oil (pint, DC560)	1	S156201A

* Included in power unit kit.