

Gas pressure Regulator RMG 361



**Operation and Maintenance,
Spare Parts**

361.20
edition 06/1997



CONTROLS SUPPLY CHAIN
VALVES ACTUATORS INSTRUMENTATIONS

Serving the Gas Industry - WORLDWIDE





Content

1.	General	p. 3
2.	Assembly and Function	p. 4
3.	Assembly	p. 5
4.	Start-up	p. 5
5.	Maintenance	p. 5
5.1.	General Maintenance Instructions	p. 5
5.2.	Special Maintenance Instructions	p. 6
5.3.	Torques	p. 7
5.4.	Lubricants	p. 7
5.5.	Locking Washers	p. 7
6.	Spare Parts Drawings	p. 8
6.1.	Spare Parts Drawing RMG 361 Drive 1	p. 8
6.2.	Sectional View A - A	p. 9
6.3.	RMG 361 Drive 1 with Safety Diaphragm	p. 10
6.4.	RMG 361 Drive 2	p. 11
6.5.	RMG 361 Drive 3	p. 12
6.6.	Detailed Drawing - SAV-Valve Flap	p. 13
6.7.	Electric SAV-Position Indicator - Connection Scheme	p. 13
6.8.	SAV - Control Device K 1a	p. 14
7.	Spare Parts Lists	p. 15
7.1.	Spare Parts List RMG 361	p. 15
	Pos. No. 1-26	p. 15
	Pos. No. 27-42	p. 16
	Pos. No. 43-77	p. 17
	Pos. No. 78-110	p. 18
	Pos. No. 111-146	p. 19
	Pos. No. 147-181	p. 20
	Pos. No. 182-191	p. 21



1. General

The construction, set-up, start-up and the maintenance of the gas pressure regulator (GDR) are subject to special technical rules which should be strictly observed, in particular those given by DVGW-Worksheets G 490/I, G 491, G 495 and the RMG-leaflet "General Operating Instructions for Gas Pressure Regulators and Safety Devices" .

Our leaflet RMG 361.00 consists of technical data, different versions and dimensions.

The GDR is suitable for gases according to DIN EN 437 and DVGW-Worksheets G 260 as well as G 280 and other non corrosive gaseous media. It can only be used with filtered gases, which residual solids have a grain size not superior to 10 μ m. Temperatures from -15°C up to +60°C are suitable for the GDR, if in that case the dew point temperature of the steam and of the hydrocarbon is not reached.

By stocking and transporting, the GDR must be protected from dirt, humidity and heating influences over 60°C and the connection flanges must remain closed.

2. Assembling and Function (see drawing on page 4)

The GDR consists of a casing (1), a regulating device (200) in connection with a valve rod (7) and a valve plate (31), a safety relief valve against leakage (204) and a safety shut-off valve consisting of a block cap (201), a switching device (202) and a control device (203).

The outlet pressure to be set-up is conducted to measuring unit (comparator).

The force (34) arising from the outlet pressure is compared to the force of the setpoint spring (34) on the measuring diaphragm (26). The variation coming from the setpoint/instantaneous value provokes a movement of the valve plate (31) on the valve rod (7). The corresponding pressure variation enables an adjustment of the outlet pressure to its setpoint value.

The force arising from the inlet pressure on the valve plate (31) is balanced with the compensation diaphragm. A boring within the valve rod (7) enables a pressure loading of the casing into the room over the compensation diaphragm (27), so that the forces coming from the casing pressure on the valve plate are also compensated.

To reduce noise, a ring (42) can be set-up. The corresponding recess within the casing and the cover (4) is standard to locate the ring.

By reaching the response pressure which is given by the location of the force of the spring (35), small leakage quantities can be carried away over the breathing line.

For the version with the safety diaphragm, the safety diaphragm (91) is situated over the diaphragm (26) which is laid down on the diaphragm cap in case of a diaphragm break; it prevents from gas penetration into the atmosphere.

When the outlet pressure reaches the response pressure of the safety shut-off valve, a 90°-swivelled cap (201) blocks the gas stream. By opening the cap (201) the flap shaft (6) is stopped by the positioning of the engaging socket (18). After the corresponding control device, the engaging socket is axially pushed all of a sudden. The balls (118) can be pressed into the recess of the engaging socket; the cap begins to close after torques operated by the spring (19).

To open the safety shut-off valve, the closing cover (63) of the control device is unscrewed and screwed on the spindle (53). After reaching the service pressure, the control device is blocked by pulling the spindle (53). Then, a valve set in the cap (see 6.6. p. 13) is open -internal manner- where the pressure compensation is reached on the cap, before the cap can be rotated in the opening position.



Drawing: Assembly and Function RMG 361

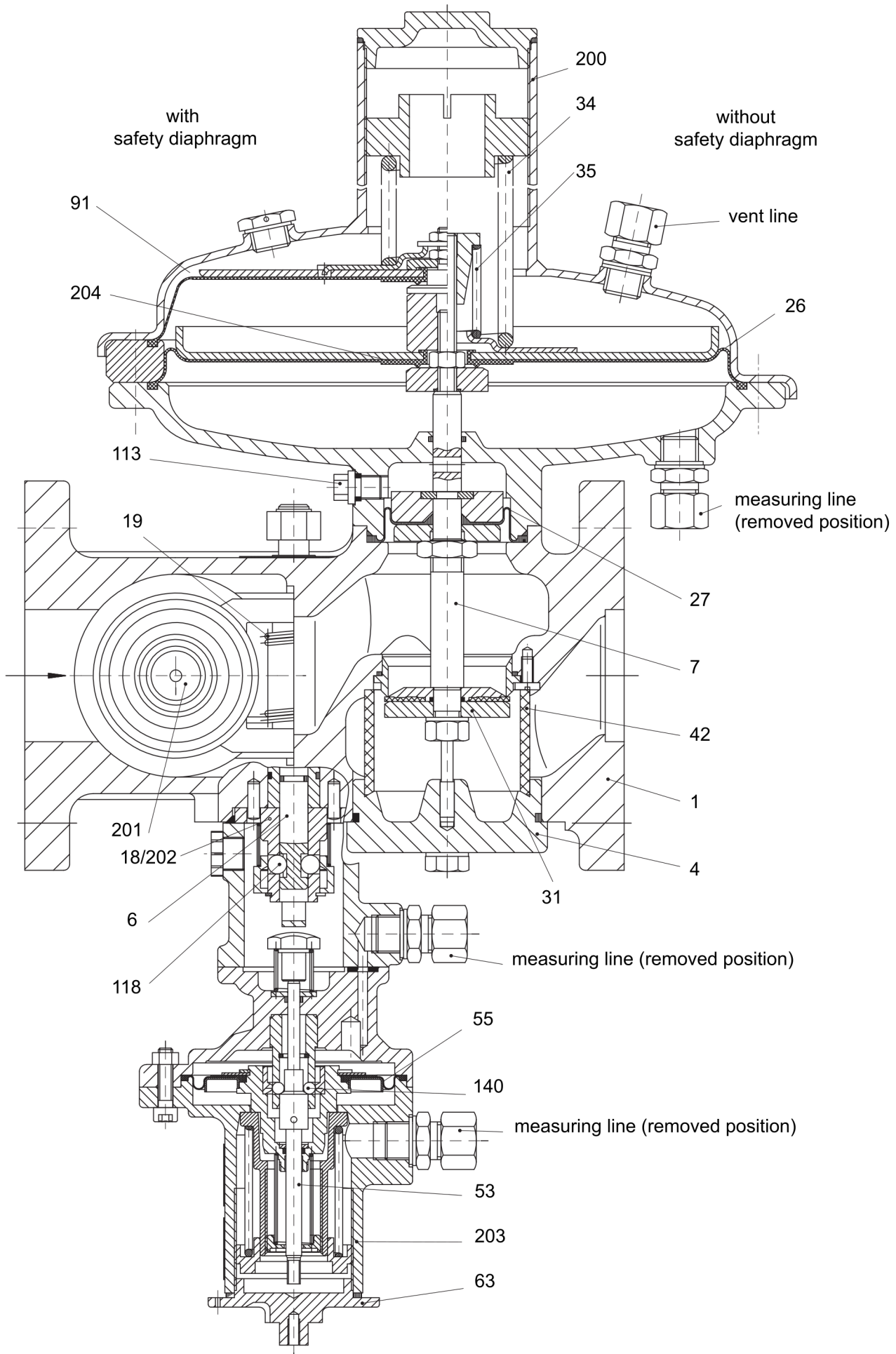



3. Assembling

For the assembly of the GDR it is important to pay attention to the following points:

- the installation must be done in an horizontal tube line
- the direction arrow on the GDR must indicate the flow direction of the gas
- stress-free assembly:
 - connection flanges of the tube line are parallel and axial to the casing flanges
 - moments should influence the GDR
- the tube lines must not be dirty
- by cleaning the complete tube line, the GDR must be replaced by a form tube
- the distance between the tube line and the outlet flange or between the tube line socket and the connection of the measuring line (measuring point) must be 5 X DN and the distance between the measuring point and the next shut-off device must be 3 X DN
- a steady flow must exist on the measuring point with a velocity of maxi. 20 m/s

The active lines consisting of steel tube of 12 X 1,5 or 16 X 2 must be connected ready to be operated to the corresponding tube union pieces of the GDR.

For the open-air operation the GDR must be set under a protection roof.

The position indicator of the SAV must be connected according to the drawing position 6.7. on page 13.

4. Start-up

- after opening the shut-off device placed before the GDR with a spanner, withdraw the gas from the SAV very slowly and increase the pressure after the SAV, so that the control device can be admitted over the regulating device or the separate test valve (f.i.RMG 911)
- set and control the response pressure of the control device
- create a pressure compensation on the valve cap and open the valve shaft
- set the regulating device at the setpoint value wanted and control it over the blow-off line
- open the shut-off device after the GDR. Correct the setpoint indication if necessary

5. Maintenance

5.1. General Maintenance Instructions

The frequency of periodical maintenance to be foreseen should be determined according to the prevailing service conditions and the type and composition of the gaseous media. We, therefore, abstain from imposing any fixed intervals and would rather refer you to the recommendations given by the DVGW-Worksheet G 495. For maintenance all parts must be cleaned and subject to a thorough visual inspection. A visual inspection should not be omitted when the course of operation or functional tests have shown lack of regulating accuracy. Particular care should be given to the checking of sealings and diaphragms, as well as of all carrying and moving parts. Damaged parts should be replaced by new ones.

Diaphragms, valves sealings, circlips and o-rings must be kept available for maintenance works. Those parts are marked by EV in the spare parts lists and in drawings 8 to 14.

5.2. Special Maintenance Instructions

- When loosening or screwing the nuts onto the valve rod of the regulating device, the valve rod must be held in position with a drift, thus preventing any rotation of the valve rod that would damage the compensating diaphragm.

Stock-nr. 15 801 206 - DN 25/50
15 801 216 - DN 80/100

Drawing: Protecting the valve rod against rotation

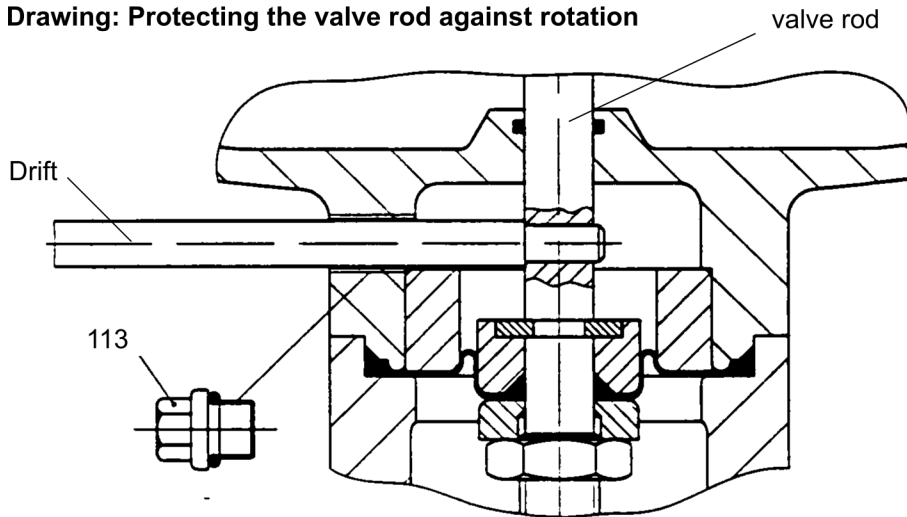

Note

- the setpoint spring must be released
 - take the closing screw (113) away
 - put the drift into the boring of the valve rod through the casing boring
-
- When installing the valve rod, its boring must be aligned to the boring of the closing screw (113).
 - so that the clap shafts (pos-no. 6, page 9) support the two balls (pos-no. 118 page 9) in the opening position, the assembly of the switching casing (pos-nr. 3 page 9) must be done in a stopped opening position of the shaft.
 - the assembly of the rotation spring (pos-nr.19 page 9) can be made in a stressed condition if necessary with the facility according to stock-nr. 15 801 205 - DN 25/50
15 801 215 - DN 80/100



5.3. Torques

drawing on page	pos.	torques Nm	
		DN 25/50	DN 80/100
8 and 9	37	5	18
	106	8	
	109	8	8
	105, 107, 108	18	18
	103, 162	18	40
	10	106	8
	105, 107	18	
11	107	8	8
	170	18	18
	167		40
12	174		18
	176		40
14	142	8	8

5.4. Lubricants

construction part	lubricants	stock-nr.
allo-rings		
all sliding surfaces		Tube 00 027 081
fixed end and loops areas of diaphragms	Silikonfett (mit dünnem Schmierfilm auftragen)	Dose 00 027 079
balls pos. 118 p. 9 balls pos. 140 p. 14		
all fastening and pipe screws	Hochdruckfett	00 027 058

5.5. Locking Washers

construction part	safety media	stock-nr.
pressure piece pos. 59 p. 14	liquid glue solidity "medium"	00 26 688
threaded pin pos. 149 p. 10	liquid glue solidity "high"	00 026 690



6. Spare Parts Drawings

6.1 Spare Parts Drawing RMG 361 Drive 1

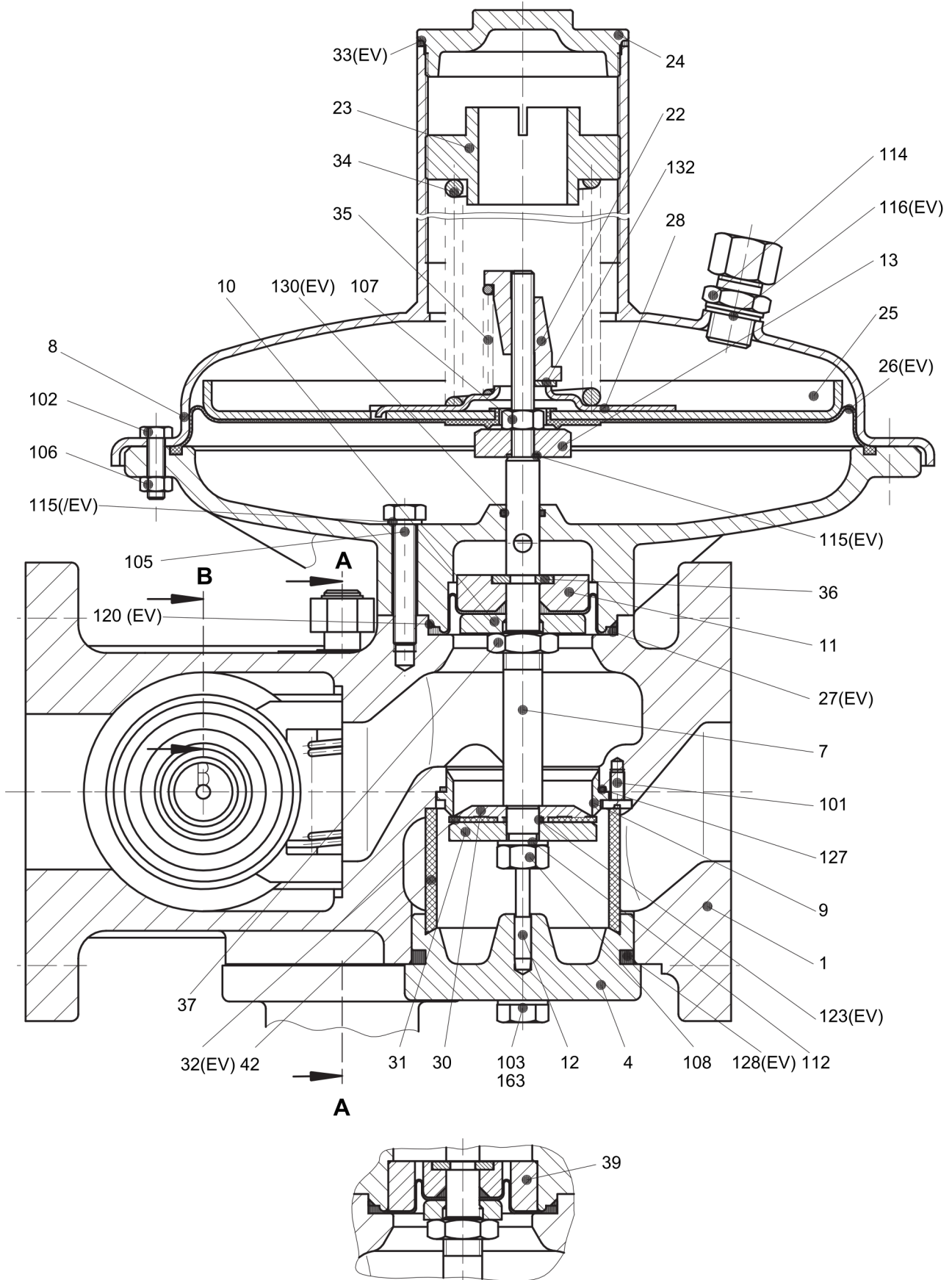

valves 25, 31

Notice

Parts marked by EV to be kept in stock for maintenance



6.2. Spare Parts Drawing RMG 361

A - A

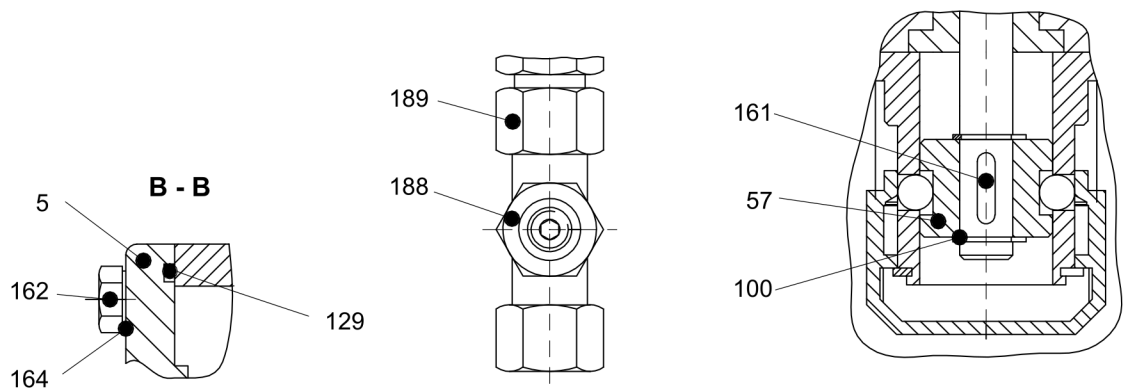
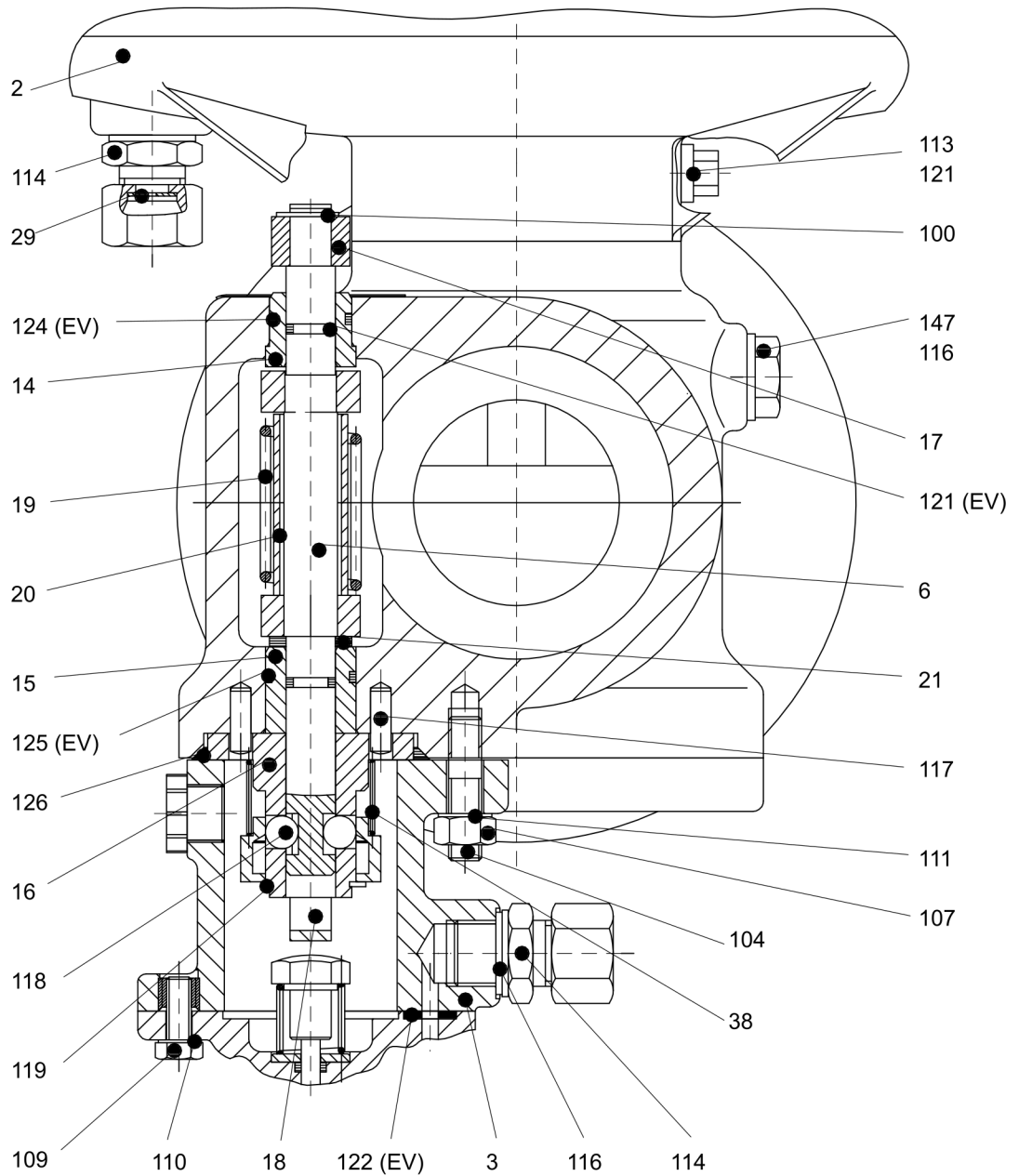

with throttling valve

DN 80 / DN 100

Notice

Parts marked by EV to be kept in stock for maintenance

6.3. Spare Parts Drawing RMG 361 Drive 1 with safety diaphragm

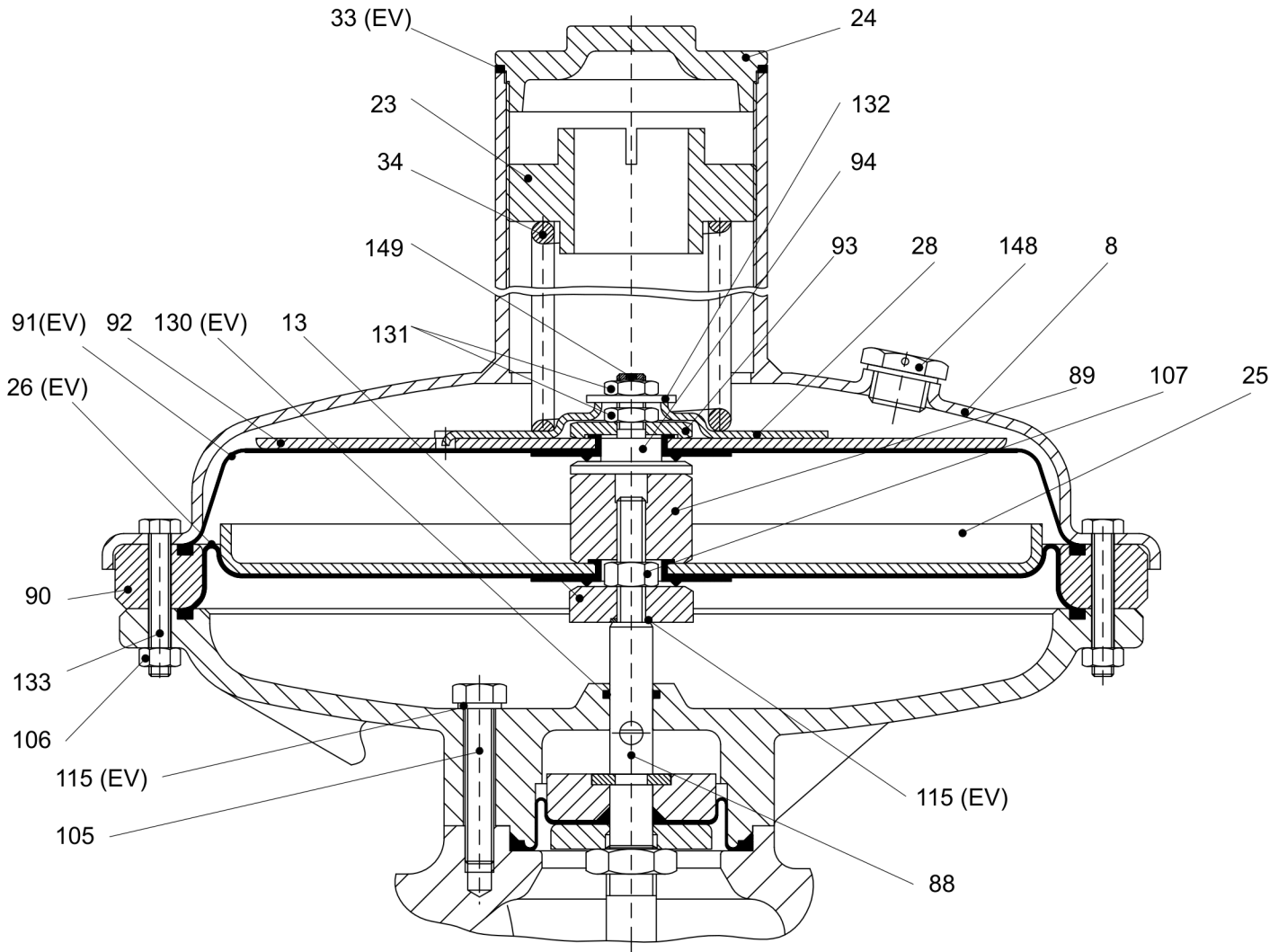

Notice Parts marked by EV to be kept in stock for maintenance



6.4 Spare Parts Drawing RMG 361 Drive 2

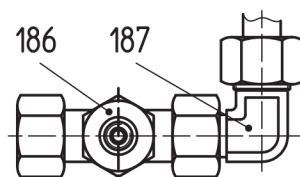
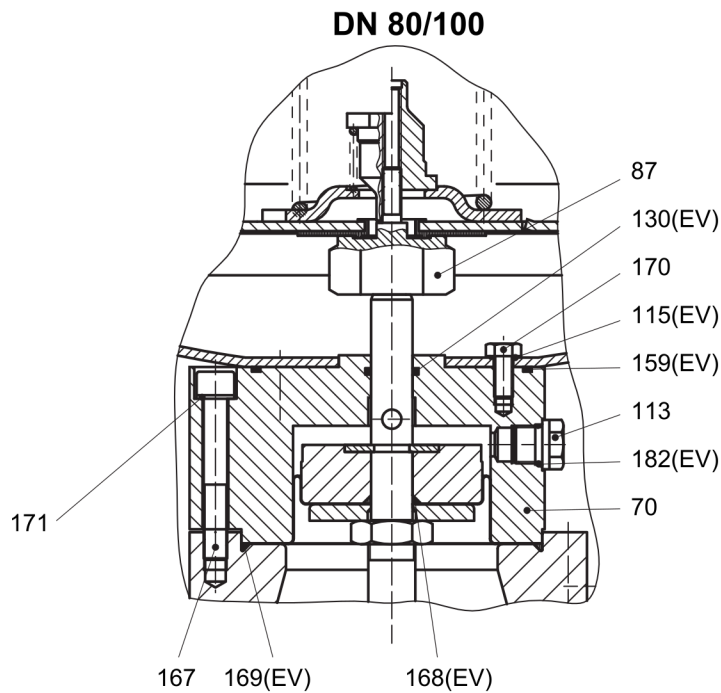
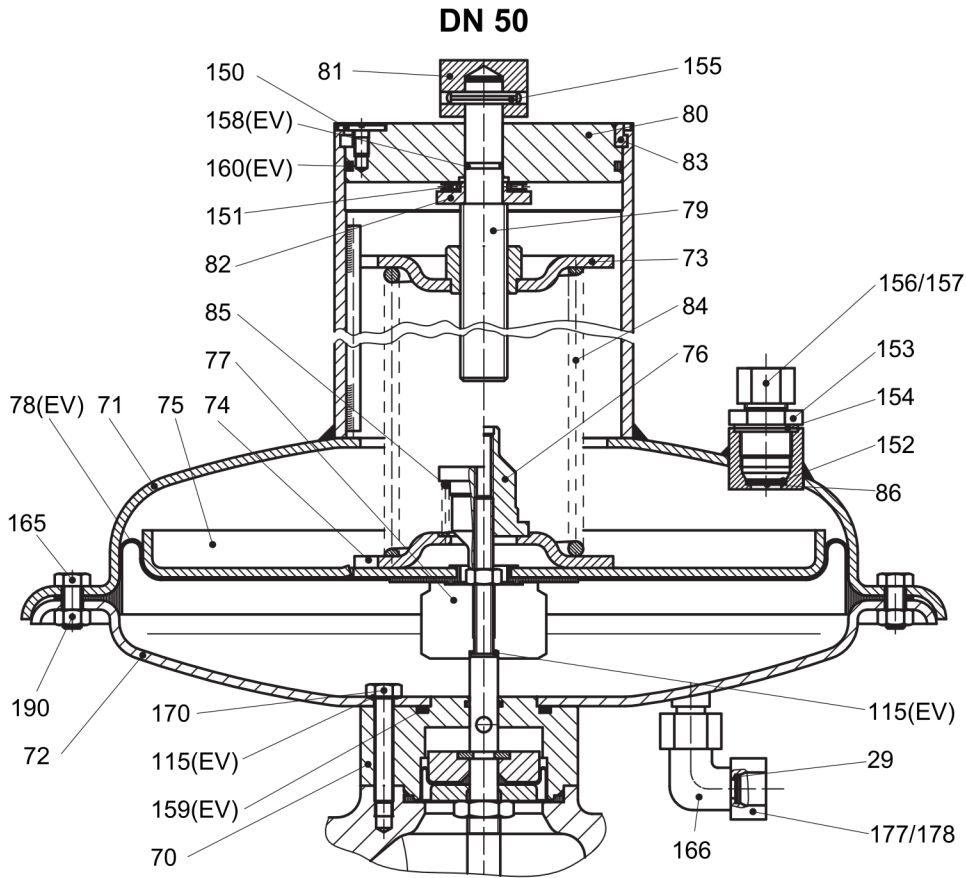

with throttling valve

Notice

Parts marked by EV to be kept in stock for maintenance



6.5 Spare Parts Drawing Drive 3 DN 80/100

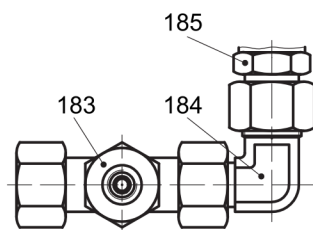
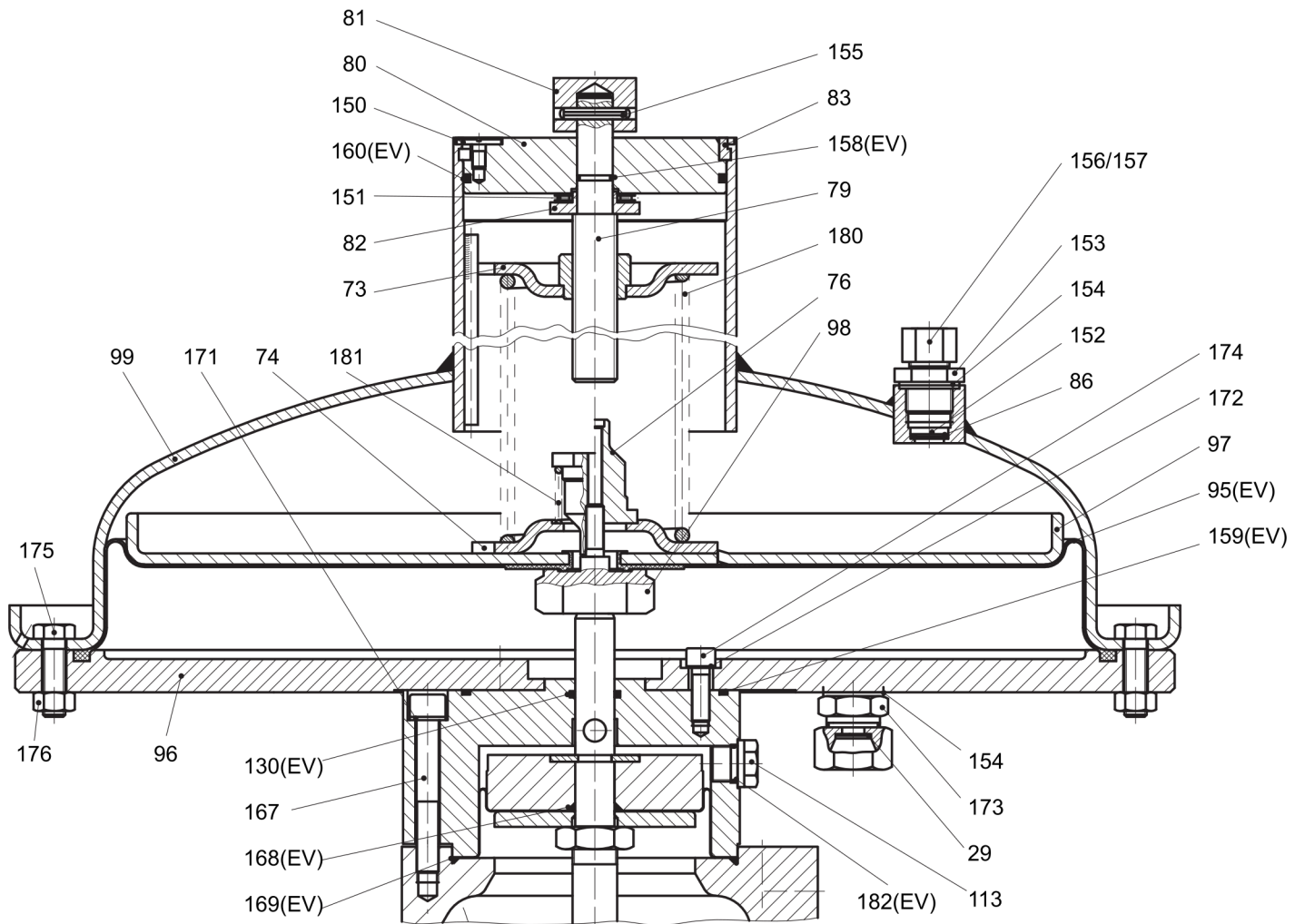

with throttling valve

Notice

Parts marked by EV to be kept in stock for maintenance



6.6. Detailed Drawing - SAV- Valve Flap

DN 50, 80, 100

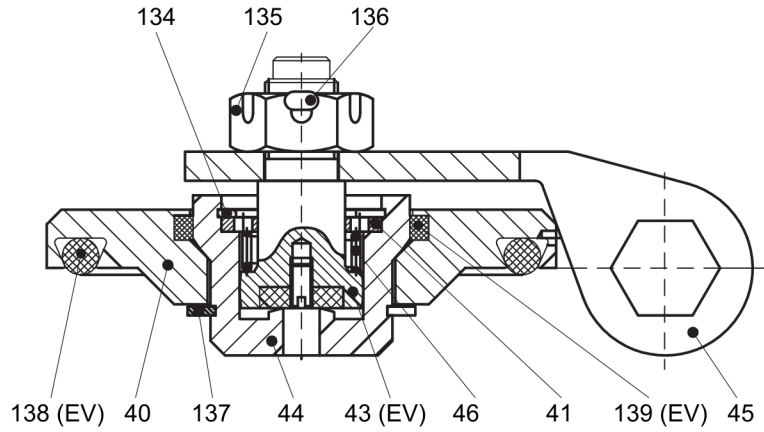

DN 25

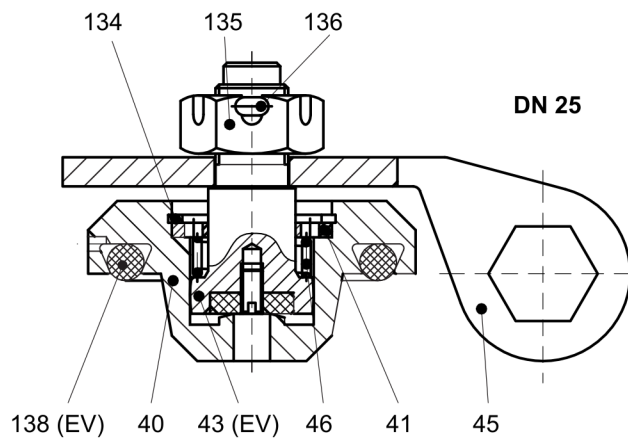

6.7. Electric SAV-Position Indicator - Connection Scheme

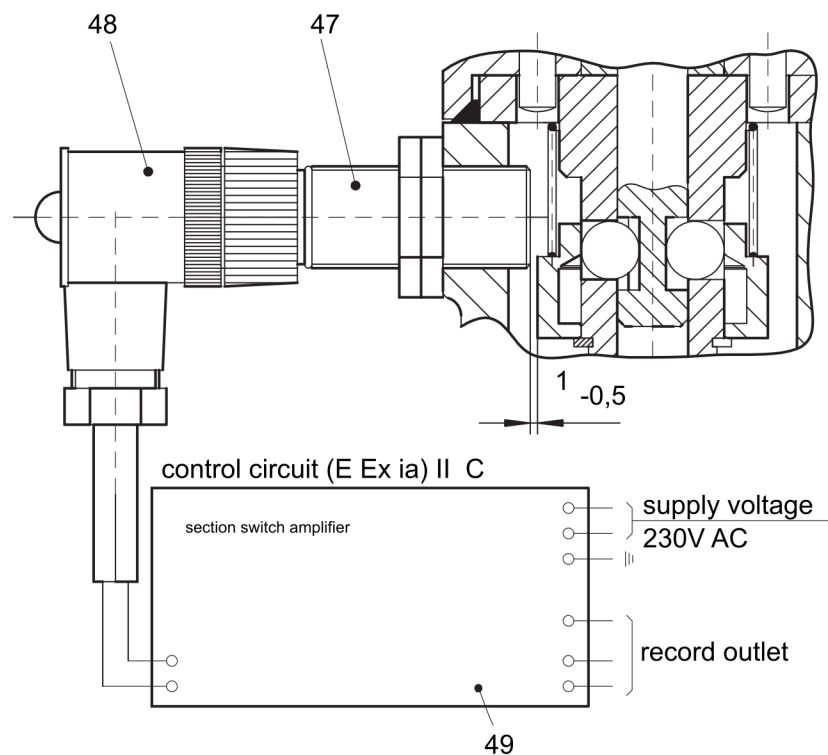



6.8. SAV - Control Device K 1a

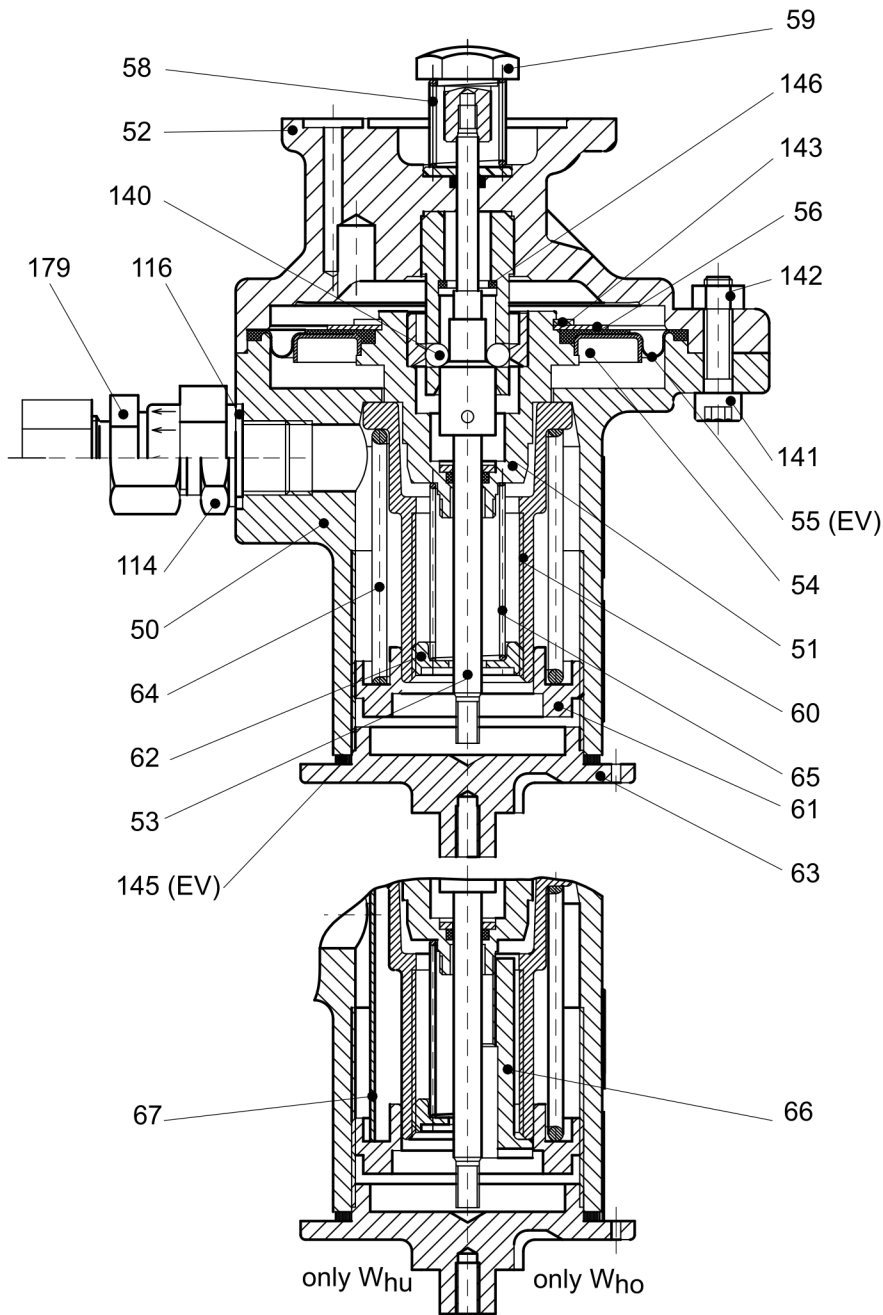

Notice

Parts marked by EV to be kept in stock for maintenance



7. Spare Parts Lists

7.1. Spare Parts List RMG 361

pos. nr.	description	quant	E EV	material	stock-nr.			
					DN 25	DN 50	DN 80	DN 100
1	casing	1	E	GGG	15 025 001	15 026 010	15 027 001	15 028 001
2	diaphragm casing with bush	1	E	GLM/NSt	15 026 250	15 026 250		
3	switching device	1	E	GLM	15 025 008	15 025 008	15 027 006	15 027 006
4	cover	1	E	GLM	15 025 002	15 026 015	15 027 004	15 028 002
5	SAV-cover	2	E	GGG	15 026 034	15 026 034	15 027 005	15 028 003
6	flap shaft-SAV	1	E	MS/St	15 026 400	15 026 400	15 027 008	15 027 008
7	valve rod, complete	1	E	Ms/NSt/St	15 025 300	15 026 300	15 027 200	15 027 200
8	diaphragm cover, complete	1	E	St	15 026 200	15 026 200		
9	valve seat-ø 25	1	E	LM	15 025 012			
	valve seat-ø 31	1	E	LM	15 025 003	15 026 802		
	valve seat-ø 50	1	E	LM		15 026 009		
	valve seat-ø 60	1	E	LM			15 027 003	15 028 004
	valve seat-ø 80	1	E	LM			15 027 002	15 028 005
	valve seat-ø 100	1	E	LM				15 028 006
10	pressure disc-ø 25	1	E	LM	15 025 014			
	pressure disc-ø 31	1	E	LM	15 026 804	15 026 804		
	pressure disc-ø 50	1	E	LM		15 026 011		
	pressure disc-ø 60	1	E	LM			10 009 124	10 009 124
	pressure disc-ø 80	1	E	LM			10 009 125	10 009 125
	pressure disc-ø 100	1	E	LM				10 009 128
11	diaphragm disc-ø 25	1	E	LM	15 025 015			
	diaphragm disc-ø 31	1	E	LM	15 026 805	15 026 805		
	diaphragm disc-ø 50	1	E	LM		15 026 012		
	diaphragm disc-ø 60	1	E	LM			10 009 142	10 009 142
	diaphragm disc-ø 80	1	E	LM			10 009 141	10 009 141
	diaphragm disc-ø 100	1	E	LM				10 009 127
12	rod	1	E	NSt	15 026 013	15 026 013	15 027 010	15 027 010
13	limiting piece, drive 1	1	E	LM	15 026 014	15 026 014		
14	bush	1	E	NSt	15 025 016	15 026 016	15 026 016	15 026 016
15	bush	1	E	NSt	15 026 017	15 026 017	15 027 012	15 027 012
16	guide bush	1	E	Ms	15 026 018	15 026 018	15 027 017	15 027 017
17	driver	1	E	NSt	15 026 019	15 026 019	15 026 019	15 026 019
18	engaging socket	1	E	NSt	15 026 020	15 026 020	15 027 018	15 027 018
19	rotary spring	1	E	NSt	15 026 022	15 026 022	15 027 022	15 027 022
20	sleeve	1	E	NSt	15 026 023	15 026 023	15 027 014	15 027 014
21	bearing, axial	1	E	K	15 026 024	15 026 024	15 027 021	15 027 021
22	spring plate, drive 1	1	E	LM	15 026 025	15 026 025		
23	position screw, drive 1	1	E					
	Wh 20-200mbar	1	E	GZn	10 003 638	10 003 638		
	Wh 150-500mbar	1	E	GZn/St	10 003 637	10 003 637		
24	cap, ready-made part	1	E	GZn	10 003 641	10 003 641		
25	diaphragm plate, drive 1	1	E	LM	10 003 625	10 003 625		
26	rolling diaphragm, drive 1	1	EV	KG	15 026 001	15 026 001		
LM	... light metal			Ms	... brass	GGG	... spheroidal graphite cast iron	
GLM	... light metal cast			K	... plastic material			
St	... steel			KG	... rubber-like plastic material			
NSt	... stainless steel			GZn	... zink cast			
FSt	... spring steel			AIBz	... aluminium bronze			
NFSt	... stainless spring steel							



pos. nr.	description	quan	E EV	material	stock-nr.			
					DN 25	DN 50	DN 80	DN 100
27	diaphragm-ø 25	1	EV	KG	15 025 011			
	diaphragm-ø 31	1	EV	KG	15 026 801	15 026 801		
	diaphragm-ø 50	1	EV	KG		15 026 002		
	diaphragm-ø 60	1	EV	KG			10 009 120	10 009 120
	diaphragm-ø 80	1	EV	KG			10 009 134	10 009 134
	diaphragm-ø 100	1	EV	KG				10 009 137
28	spring plate, drive 1	1	E	St	10 003 626	10 003 626		
29	disc	1	E	LM	15 026 029	15 026 029	15 027 027	15 027 027
30	pressure piece-ø 25	1	E	LM	10 006 184			
	pressure piece-ø 31	1	E	LM	10 009 199	10 009 199		
	pressure piece-ø 50	1	E	LM		10 009 197		
	pressure piece-ø 60	1	E	LM			10 009 208	10 009 208
	pressure piece-ø 80	1	E	LM			10 009 207	10 009 207
	pressure piece-ø 100	1	E	LM				10 009 206
31	valve plate-ø 25	1	E	LM	10 023 463			
	valve plate-ø 31	1	E	LM	10 023 464	10 023 464		
	valve plate-ø 50	1	E	LM		15 026 028		
	valve plate-ø 60	1	E	LM			10 009 211	10 009 211
	valve plate-ø 80	1	E	LM			10 009 210	10 009 210
	valve plate-ø 100	1	E	LM				10 009 209
32	valve sealing-ø 25	1	EV	KG	10 006 183			
	valve sealing-ø 31	1	EV	KG	10 009 215	10 009 215		
	valve sealing-ø 50	1	EV	KG		10 009 217		
	valve sealing-ø 60	1	EV	KG			10 009 218	10 009 218
	valve sealing-ø 80	1	EV	KG			10 009 219	10 009 219
	valve sealing-ø 100	1	EV	KG				10 009 220
33	locking sealing ring, drive 1	1	EV	K	10 003 640	10 003 640		
34	pressure spring: Wh 20- 50mbar	1	E	FSt	10 003 629	10 003 629		
	drive 1 Wh 45-100mbar	1	E	FSt	10 003 630	10 003 630		
	Wh 90-200mbar	1	E	FSt	10 003 631	10 003 631		
	Wh 150-300mbar	1	E	FSt	10 003 632	10 003 632		
	Wh 250-400mbar	1	E	FSt	10 003 633	10 003 633		
	Wh 350-500mbar	1	E	FSt	10 003 634	10 003 634		
35	pressure spring SBV, drive 1	1	E	FSt	10 003 636	10 003 636		
36	ring segment	1	E	St	10 008 612	10 008 612	10 009 129	10 009 129
37	hexagonal nut	1	E	St	10 009 045	10 009 045	10 009 109	10 009 109
38	pressure spring	1	E	NFSt	15 026 005	15 026 005	15 027 015	15 027 015
39	reduction piece 25	1	E	LM	15 025 013			
	reduction piece 31	1	E	LM	15 026 803	15 026 803		
40	plate	1	E	Ms	15 025 102	15 026 102	15 027 102	15 028 102
41	disc	1	E	Ms	15 026 104	15 026 104	15 026 104	15 026 104
42	metal-foamed ring	1	E	NSt	15 025 006	15 026 027	15 027 023	15 028 008

LM	... light metal	Ms	... brass	GGG	... spheroidal graphite cast iron
GLM	... light metal cast	K	... plastic material		
St	... steel	KG	... rubber-like plastic material		
NSt	... stainless steel	GZn	... zink cast		
FSt	... spring steel	AlBz	... aluminium bronze		
NFSt	... stainless spring steel				



pos. nr.	description	quan	E EV	material	stock-nr.				
					DN 25	DN 50	DN 80	DN 100	
43	piston, premounted	1	EV	NSt/KG	15 025 110	15 026 110	15 026 110	15 026 110	
44	valve insert	1	E	Ms		15 026 103	15 026 103	15 026 103	
45	lever	1	E	NSt	15 025 101	15 026 101	15 027 101	15 028 101	
46	pressure spring	1	E	NFSt	15 026 105	15 026 105	15 026 105	15 026 105	
47	proximity switch	1	E		00 024 160	00 024 160	00 024 160	00 024 160	
48	cable bush	1	E		00 024 099	00 024 099	00 024 099	00 024 099	
49	section switch 230V 1-channel	1	E		00 024 402	00 024 402	00 024 402	00 024 402	
	230V 2-channel	1	E		00 024 403	00 024 403	00 024 403	00 024 403	
50	spring casing	1	E	GLM	10 010 608	10 010 608	10 010 608	10 010 608	
51	engaging socket, complete	1	E	LM/St/KG	10 010 619	10 010 619	10 010 619	10 010 619	
52	SAV-ground, complete	1	E	GLM/AIBz/KG	10 010 605	10 010 605	10 010 605	10 010 605	
53	valve rod, complete	1	E	NSt/St	10 010 614	10 010 614	10 010 614	10 010 614	
54	diaphragm plate	1	E	St	10 010 611	10 010 611	10 010 611	10 010 611	
55	diaphragm	1	EV	KG	10 010 610	10 010 610	10 010 610	10 010 610	
56	pressure disc	1	E	LM	10 004 882	10 004 882	10 004 882	10 004 882	
57	hub, complete	1	E	Ms			15 027 300	15 027 300	
58	pressure spring	1	E	FSt	10 011 077	10 011 077	10 011 077	10 011 077	
59	pressure piece	1	E	LM	15 026 511	15 026 511	15 026 511	15 026 511	
60	spring retainer	1	E	K	10 008 563	10 008 563	10 008 563	10 008 563	
61	spring plate	1	E	Ms	10 001 844	10 001 844	10 001 844	10 001 844	
62	spring plate	1	E	K	10 000 856	10 000 856	10 000 856	10 000 856	
63	SAV-cap	1	E	GLM	10 000 854	10 000 854	10 000 854	10 000 854	
64	pressure spring Who 50-100mbar	1	E	FSt	10 001 838	10 001 838	10 001 838	10 001 838	
	SAV Who 80-200mbar	1	E	FSt	10 000 866	10 000 866	10 000 866	10 000 866	
	Who 200-500mbar	1	E	FSt	10 000 867	10 000 867	10 000 867	10 000 867	
	Who 400-1500mbar	1	E	FSt	10 001 839	10 001 839	10 001 839	10 001 839	
65	pressure spring Whu 10-15mbar	1	E	FSt	10 001 828	10 001 828	10 001 828	10 001 828	
	SAV Whu 14-40mbar	1	E	FSt	10 001 837	10 001 837	10 001 837	10 001 837	
	Whu 35-120mbar	1	E	FSt	10 001 760	10 001 760	10 001 760	10 001 760	
66	tube	1	E	LM	10 024 060	10 024 060	10 024 060	10 024 060	
67	retention tube	1	E	LM	10 001 784	10 001 784	10 001 784	10 001 784	
70	distance piece with bush								
	valve-ø 31/50	1	E	LM/NSt		15 026 901			
	valve-ø 60	1	E	LM/NSt			15 027 250	15 028 200	
	valve-ø 80	1	E	LM/NSt			15 027 260	15 028 210	
	valve-ø 100	1	E	LM/NSt				15 028 220	
71	diaphragm cover, complete	1	E	St		10 009 036	15 027 350	15 027 350	
72	diaphragm, complete	1	E	St		15 026 910	10 009 037	10 009 037	
73	spring plate, complete	1	E	St/Ms		10 009 067	10 009 067	10 009 067	
74	spring plate	1	E	St		10 009 102	10 009 102	10 009 102	
75	diaphragm plate	1	E	LM		10 009 168	10 009 168	10 009 168	
76	adjustment piece	1	E	LM		10 009 178	10 009 178	10 009 178	
77	limiting piece, drive 2	1	E	LM		15 026 902			
LM	... light metal			Ms	... brass			GGG	... spheroidal graphite cast iron
GLM	... light metal cast			K	... plastic material				
St	... steel			KG	... rubber-like plastic material				
NSt	... stainless steel			GZn	... zink cast				
FSt	... spring steel			AIBz	... aluminium bronze				
NFSt	... stainless spring steel								



pos. nr.	description	quan	E EV	material	stock-nr.				
					DN 25	DN 50	DN 80	DN 100	
78	rolling diaphragm	1	EV	KG		10 009 046	10 009 046	10 009 046	
79	adjustment spindle	1	E	St		10 009 056	10 009 056	10 009 056	
80	closing plate	1	E	LM		10 009 065	10 009 065	10 009 065	
81	hexagonal adjusting ring	1	E	St		10 009 055	10 009 055	10 009 055	
82	support ring	1	E	St		10 009 057	10 009 057	10 009 057	
83	half-ring	2	E	St		10 009 061	10 009 061	10 009 061	
84	pressure spring, Wh 20-50mbar	1	E	FSt		10 009 068	10 009 068	10 009 068	
	drive 2 Wh 45-100mbar	1	E	FSt		10 009 069	10 009 069	10 009 069	
	Wh 90-200mbar	1	E	FSt		10 009 070	10 009 070	10 009 070	
	Wh 150-300mbar	1	E	FSt		10 009 071	10 009 071	10 009 071	
	Wh 250-400mbar	1	E	FSt		10 009 072	10 009 072	10 009 072	
	Wh 350-500mbar	1	E	FSt		10 009 073	10 009 073	10 009 073	
85	pressure spring, pa + 15mbar	1	E	FSt		10 009 151	10 009 151	10 009 151	
	SBV-A2 pa + 40mbar	1	E	FSt		10 009 152	10 009 152	10 009 152	
	pa + 125mbar	1	E	FSt		10 009 153	10 009 153	10 009 153	
86	rubber slotted disc	1	E	KG		10 003 607	10 003 607	10 003 607	
87	limiting piece., drive 2	1	E	St			10 009 177	10 009 177	
88	valve rod, complete	1	E	Ms/NSt/St	15 025 510	15 026 620			
89	distance piece	1	E	NSt	15 026 601	15 026 601			
90	ring-SM	1	E	LM	15 026 602	15 026 602			
91	safety diaphragm	1	EV	KG	15 026 611	15 026 611			
92	diaphragm plate	1	E	LM	10 004 798	10 004 798			
93	distance piece	1	E	LM	10 006 178	10 006 178			
94	fixing screw	1	E	LM	10 006 177	10 006 177			
95	rolling diaphragm	1	EV	KG			15 027 502	15 027 502	
96	ground	1	E	St			15 027 503	15 027 503	
97	diaphragm plate	1	E	LM			15 027 504	15 027 504	
98	distance piece, drive 3	1	E	St			15 027 505	15 027 505	
99	diaphragm cover	1	E	St			15 027 510	15 027 510	
100	locking washer	1	E	NFSt	00 019 199	00 019 199			
		3	E	NFSt			00 019 199	00 019 199	
101	pan-head screw	3	E	St		00 011 145			
102	hexagonal screw	16	E	St	00 010 116	00 010 116			
103	hexagonal screw	2	E	St	00 010 630	00 010 630			
		3		St			00 010 631	00 010 631	
104	locking screw	3	E	St	00 012 473	00 012 473	00 012 473	00 012 473	
105	hexagonal screw	4	E	St	00 010 629	00 010 629			
106	hexagonal nut	16	E	St	00 003 399	00 003 399			
107	hexagonal nut	4	E	St	00 005 559	00 005 559	00 005 559	00 005 559	
108	hexagonal nut	1	E	St	00 005 692	00 005 692	00 013 203	00 013 203	
109	hexagonal screw	4	E	St	00 008 172	00 008 172	00 008 172	00 008 172	
110	locking washer	4	E	St	00 014 123	00 014 123	00 014 123	00 014 123	
LM	... light metal			Ms	... brass			GGG	... spheroidal graphite cast iron
GLM	... light metal cast			K	... plastic material				
St	... steel			KG	... rubber-like plastic material				
NSt	... stainless steel			GZn	... zink cast				
FSt	... spring steel			AlBz	... aluminium bronze				
NFSt	... stainless spring steel								



pos. nr.	description	quan	E EV	material	stock-nr.			
					DN 25	DN 50	DN 80	DN 100
111	locking washer	3	E	St	00 014 122	00 014 122	00 014 122	00 014 122
112	locking washer	1	E	St	00 014 121	00 014 121	00 014 116	00 014 116
113	closing screw	1	E	St	00 010 633	00 010 633	00 010 634	00 010 634
114	union piece drive 1	4	E	St	00 030 026	00 030 026		
	drive 1-SM	3	E	St	00 030 026	00 030 026		
	drive 2/3	2	E	St		00 030 026	00 030 026	00 030 026
115	sealing ring drive 1	5	EV	Al	00 018 710	00 018 710		
	drive 2	4	EV	Al			00 018 710	00 018 710
116	sealing ring drive 1	6	EV	Al	00 018 789	00 018 789		
	drive 1-SM	5	EV	Al	00 018 789	00 018 789		
	drive 2/3	4	EV	Al			00 018 789	00 018 789
117	dowel pin	2	E	St	00 017 269	00 017 269	00 017 269	00 017 269
118	ball	2	E	NSt	00 005 184	00 005 184	00 005 184	00 005 184
119	safety ring	1	E	NFSt	00 019 195	00 019 195	00 019 196	00 019 196
120	o-ring	1	EV	KG	00 021 261	00 021 261		
121	o-ring	3	EV	KG	00 021 250	00 021 250		
		2	EV	KG			00 021 250	00 021 250
122	o-ring	1	EV	KG	00 021 251	00 021 251	00 021 251	00 021 251
123	o-ring	1	EV	KG	00 020 451	00 020 451	00 020 442	00 020 442
124	o-ring	1	EV	KG	00 021 253	00 021 253	00 021 253	00 021 253
125	o-ring	1	EV	KG	00 021 254	00 021 254	00 018 456	00 018 456
126	o-ring	1	E	KG	00 020 832	00 020 832		
127	o-ring	1	EV	KG	00 021 256	00 021 258	00 021 263	00 021 266
128	o-ring	1	EV	KG	00 021 271	00 520 001	00 021 267	00 021 267
129	o-ring	2	EV	KG	00 021 263	00 021 263	00 21 266	00 021 268
130	o-ring	1	EV	KG	00 021 252	00 021 252	00 020 607	00 020 607
131	hexagonal nut	2	E	St	00 013 115	00 013 115		
132	disc	1	E	St	00 014 157	00 014 157		
133	hexagonal nut	16	E	St	00 010 632	00 010 632		
134	safety ring	1	E	NFSt	00 019 197	00 019 197	00 019 197	00 019 197
135	crone nut	1	E	NSt	00 013 204	00 013 204	00 013 204	00 013 204
136	split pin	1	E	NSt	00 015 043	00 015 043	00 015 043	00 015 043
137	safety ring	1	E	NFSt	0	0 019 198	00 019 198	00 019 198
138	o-ring	1	EV	KG	00 021 255	00 021 259	00 021 262	00 021 264
139	o-ring	1	EV	KG		00 021 260	00 021 260	00 021 260
140	ball	6	E	NSt	00 005 108	00 005 108	00 005 108	00 005 108
141	cylinder screw	4	E	St	00 010 150	00 010 150	00 010 150	00 010 150
142	hexagonal nut	4	E	St	00 003 399	00 003 399	00 003 399	00 003 399
143	safety ring	1	E	FSt	00 019 131	00 019 131	00 019 131	00 019 131
145	sealing ring	1	EV	K	00 020 343	00 020 343	00 020 343	00 020 343
146	o-ring	1	E	KG	00 020 371	00 020 371	00 020 371	00 020 371
LM	... light metal			Ms ... brass			GGG ... spheroidal graphite cast iron	
GLM	... light metal cast			K ... plastic material				
St	... steel			KG ... rubber-like plastic material				
NSt	... stainless steel			GZn ... zink cast				
FSt	... spring steel			AlBz ... aluminium bronze				
NFSt	... stainless spring steel							



pos. nr.	description	quan	E EV	material	stock-nr.				
					DN 25	DN 50	DN 80	DN 100	
147	closing screw	1	E	St	00 010 634	00 010 634	00 010 634	00 010 634	
148	closing screw	1	E	K	00 027 999	00 027 999			
149	threaded pin	1	E	St	00 012 405	00 012 405			
150	pan-head screw	2	E	St		00 011 111	00 011 111	00 011 111	
151	axial needle roller bearing	1	E	St	00 026 384	00 026 384	00 026 384	00 026 384	
	axial disc	2	E	St	00 026 385	00 026 385	00 026 385	00 026 385	
152	safety ring	1	E	St	00 019 135	00 019 135	00 019 135	00 019 135	
153	union piece	1	E	St		00 030 142	00 030 142	00 030 142	
154	sealing ring	1	E	LM		00 018 787	00 018 787	00 018 787	
155	dowel pin	1	E	St		00 017 145	00 017 145	00 017 145	
156	cap nut	1	E	St		00 030 804	00 030 804	00 030 804	
157	compression ring	1	E	St		00 030 904	00 030 904	00 030 904	
158	o-ring	1	EV	KG		00 020 588	00 020 588	00 020 588	
159	o-ring	1	EV	KG		00 020 325	00 020 335	00 020 335	
160	o-ring	1	EV	KG		00 020 248	00 020 248	00 020 248	
161	fitting key	1	E	NSt			00 027 998	00 027 998	
162	hexagonal screw	8	E	St	00 010 627	00 010 627	00 010 032	00 510 001	
163	locking washer	2	E	St	00 014 121	00 014 121			
		3	E	St			00 014 119	00 014 119	
164	locking washer	8	E	St	00 014 122	00 014 122	00 014 121	00 014 119	
165	hexagonal screw	32	E	St		00 010 627	00 010 627	00 010 627	
166	union piece	1	E	St		00 031 251	00 031 252	00 031 252	
167	cylinder screw	4	E	St			00 010 610	00 010 610	
168	o-ring	1	EV	KG			00 020 442	00 020 442	
169	o-ring	1	EV	KG			00 020 428	00 020 428	
170	hexagonal screw	4	E	St		00 010 628	00 010 065	00 010 065	
171	locking washer	4	E	St			00 014 121	00 014 121	
172	locking washer	4	E	St			00 014 122	00 014 122	
173	union piece	1	E	St			00 032 622	00 032 622	
174	cylinder screw	4	E	St			00 010 551	00 010 551	
175	hexagonal screw	16	E	St			00 003 873	00 003 873	
176	hexagonal nut	16	E	St			00 005 692	00 005 692	
177	cap nut	1	E	St			00 030 807	00 030 807	
178	compression ring	1	E	St			00 030 906	00 030 906	
179	pilot valve RMG 919-1	1	E	NSt/St	10 022 971	10 022 971	10 022 971	10 022 971	
180	pressure spring Wh 20-50mbar	1	E	FSt			10 009 069	10 009 069	
	drive 3 Wh 45-100mbar	1	E	FSt			10 009 070	10 009 070	
	Wh 75-150mbar	1	E	FSt			10 009 071	10 009 071	
	Wh 125-200mbar	1	E	FSt			10 009 072	10 009 072	
	Wh 175-250mbar	1	E	FSt			10 009 073	10 009 073	
181	pressure spring, pa + 20mbar	1	E	FSt			10 009 152	10 009 152	
	SBV-A3 pa + 60mbar	1	E	FSt			10 009 153	10 009 153	
LM	... light metal			Ms	... brass			GGG	... spheroidal graphite cast iron
GLM	... light metal cast			K	... plastic material				
St	... steel			KG	... rubber-like plastic material				
NSt	... stainless steel			GZn	... zink cast				
FSt	... spring steel			AlBz	... aluminium bronze				
NFSt	... stainless spring steel								



pos. nr.	description	quan	E	material	stock-nr.			
					DN 25	DN 50	DN 80	DN 100
182	o-ring	1	EV	KG	00 021 252	00 021 252	00 021 252	00 021 252
183	throttling valve	1	E	St/Ms			10 008 996	10 008 996
184	union piece	1	E	St			00 031 203	00 031 203
185	union piece	1	E	St			00 530 001	00 530 001
186	throttling valve	1	E	St/Ms	10 004 060	10 004 060	10 008 996	10 008 996
187	union piece	1	E	St	00 530 002	00 530 002	00 031 203	00 031 203
188	throttling valve	1	E	St/Ms	10 004 060	10 004 060		
189	union piece	1	E	St	00 530 003	00 530 003		
190	hexagonal nut	32	E	St		00 005 559	00 005 559	00 005 559
191	adjusting piece	1	E	LM			15 027 506	15 027 506

LM	... light metal	Ms	... brass
GLM	... light metal cast	K	... plastic material
St	... steel	KG	... rubber-like plastic material
NSt	... stainless steel	GZn	... zink cast
FSt	... spring steel	AlBz	... aluminium bronze
NFSt	... stainless spring steel	GGG	... spheroidal graphite cast iron

We supply you with products for gas pressure regulation:



CONTROLS SUPPLY CHAIN
VALVES ACTUATORS INSTRUMENTATIONS

Serving the Gas Industry - WORLDWIDE



We reserve the right for technical changes