

Safety Check Valve Series 585 Streamchek



PRODUCT INFORMATION

**Serving the Gas Industry
Worldwide**



CONTROLS SUPPLY CHAIN
VALVES ACTUATORS INSTRUMENTATIONS

SAFETY CHECK VALVE SERIES 585 STREAMCHEK

Introduction

- The Series 585 is a high capacity, self-acting, tight shut-off, Discriminatory Check Valve for fitting between flanges, inside bolt circle, in horizontal pipe.

Application

- The valve is primarily intended for use in conjunction with safety cut-off valves (slamshut) in transmission systems pressure reduction stations. Its purpose is to automatically discriminate between faulty or healthy pressure reduction lines, identifying and initiating the isolation of a faulty (excess throughput) regulator, whilst protecting a healthy regulator against inadvertent shut-off.
- The valve may also be used as a conventional check valve in applications requiring the prevention of reverse gas flow. It is suitable for fitting between flanges to PN16: BS EN 1092-2:1997, Class 150, 300 and 600* ASA/ANSI B16.5.

* Excluding sizes 500 and 600mm

Size Range

80mm, 100mm, 150mm, 200mm, 250mm, 300mm, 350mm, 400mm, 450mm, 500mm and 600mm.

MATERIALS OF CONSTRUCTION	
Body & Door	Plated Carbon Steel: BS. 1501 - 161 - 430B
'O' Ring	High Nitrile Rubber
Spindle	Stainless Steel: BS.970 Pt. 4 416 S21. Cond. T
Bearing Plugs	Stainless Steel: BS.970 Pt. 4 416 S21.
Fastenings	H.T.S. Grade 12.9

SERVICE CONDITIONS	
Maximum Working Pressure: PN16: BS EN1092-2:1997	16 barg (232 psig)
Class 150	19 barg (275 psig)
Class 300	50 barg (725 psig)
Class 600	100 barg (1450 psig)
Reverse Pressure Differential:	
Standard Model	7 barg (101.5 psig)
Low Differential Model: Sizes 300, 350, 400, 450 & 500mm	1 barg (14.5 psig)
600mm	0.35 barg (5 psig)
Temperature Range:	-20°C to +60°C
Medium:	Natural and manufactured gases of non-aggressive nature.

Installation

- Suitable for mounting in horizontal mains only. To be installed with body tapping (eye bolt) to the top centre and nameplate arrow pointing in the direction of gas flow.
- Pipe flanges must be within 3° from vertical, otherwise closing efficiency or ΔP rating will be adversely affected. Care must be taken to ensure clearance in the downstream main and that the flange joint does not interfere with the valve door movement.

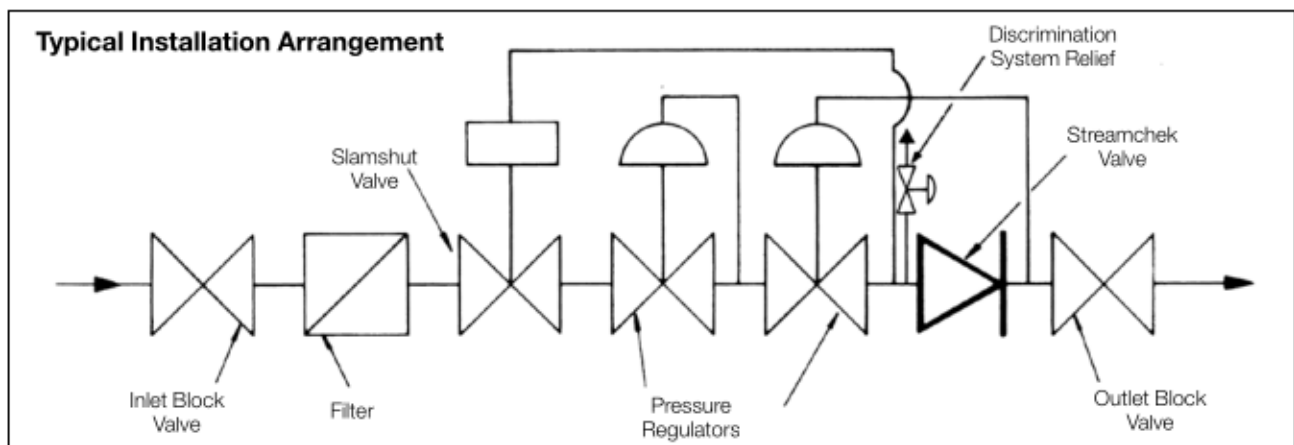



Capacity Calculation

To calculate the gas carrying capacity of a given size of valve, firstly determine the ratio of the allowable ΔP against line pressure (absolute) to obtain pressure reduction factor 'K' from the graph. Then apply this, with flow coefficient Cv given in the table (see Note 1) in the relevant two formulae:

Where, P_i = Line pressure (absolute).
 Q (Sm³/Hr) = 11.66 x Cv x K x P_i (bar Abs.)
 Q (s.c.f.h.) = 28.4 x Cv x K x P_i (psi Abs.)

Note 1

The Cv values given assume a wide-open valve absorbing a ΔP greater than 17.5 mbarg (7"wg), for lower ΔP values, multiply Cv by the respective factor as follows:

ΔP mbar (ins wg)	Factor
0.75 (0.3)	0.033
1.25 (0.5)	0.08
2.5 (1.0)	0.27
7.5 (3.0)	0.75
12.5 (5.0)	0.92

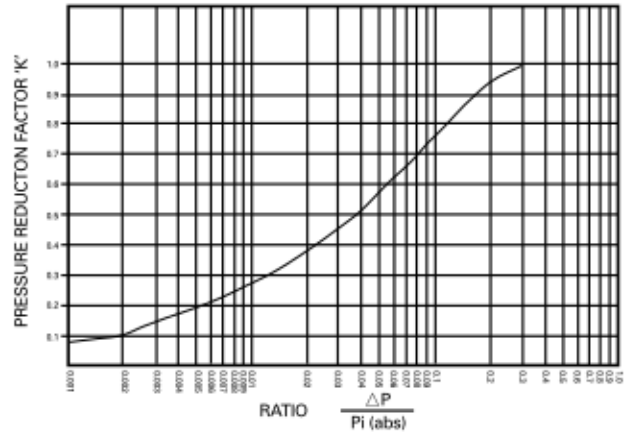

Cv Flow Coefficients:

Size	80	100	150	200	250	300	350	400	450	500	600
Cv	155	275	620	1102	1722	2480	3375	4408	5580	6888	9920

Types of Gases:

The capacities calculated are given in terms of natural gas SG 0.6. For all other gases multiply by the following correction factor:

$$\sqrt{\frac{0.6}{\text{SG of gas handled}}}$$

Dimensions & Weights

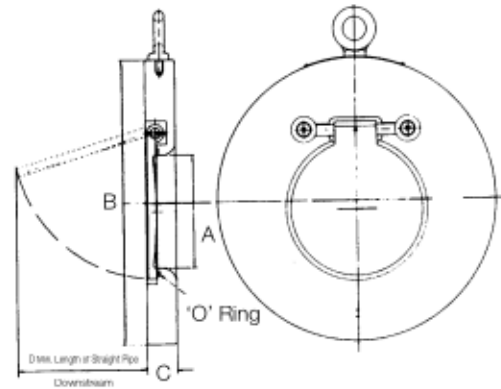

Example:

Valve Size: 250mm
 Inlet Pressure: 14 barg (203 psig)
 Allowable pressure drop: 0.3 barg (4.35 psig)
 $\Delta P/P_i$ abs = 0.02,
 therefore from graph, K = 0.37
 $Q = 11.08 \times 1722 \times 0.37 \times 15.01 = 105,963 \text{ sm}^3/\text{hr}$
OR,
 $Q = 26.98 \times 1722 \times 0.37 \times 217.7 = 3,742,271 \text{ s.c.f.h.}$

PERFORMANCE DATA														
Size	A	B				C				D	Weight kg			
		PN16	Ansi 150	Ansi 300	Ansi 600	PN16	Ansi 150	Ansi 300	Ansi 600		PN16	Ansi 150	Ansi 300	Ansi 600
80	46	136	136	148	148	19.1	19.1	19.1	19.1	60	1.85	1.85	2.4	2.4
100	58	173	173	178	191	19.1	19.1	19.1	19.1	70	2.4	2.4	3.25	3.25
150	105	219	219	248	264	23.5	23.5	22.2	28.6	136	5.5	5.5	7.5	10.5
200	150	275	275	306	320	28.6	28.6	28.6	38.1	183	10.5	10.5	13.5	19.5
250	190	331	339	360	398	38.1	38.1	38.1	57.2	229	19.5	20.5	24.0	45.0
300	225	386	408	421	455	38.1	38.1	50.8	60.3	273	25.5	30.0	42.0	60.5
350	250	446	446	485	490	44.5	44.5	50.8	66.7	300	41.0	41.0	57.5	76.5
400	294	498	514	540	565	50.8	50.8	50.8	73.0	350	56.5	61.5	70.0	110.0
450	328	558	549	595	610	60.3	60.3	76.2	82.6	387	85.0	81.0	125.0	142.0
500	366	618	605	652	-	63.5	63.5	82.6	-	435				-
600	455	728	714	772	-	66.7	66.7	82.6	-	524				-

All dimensions in mm