

Gas Pressure Regulator Series 277 Hi-Flo™

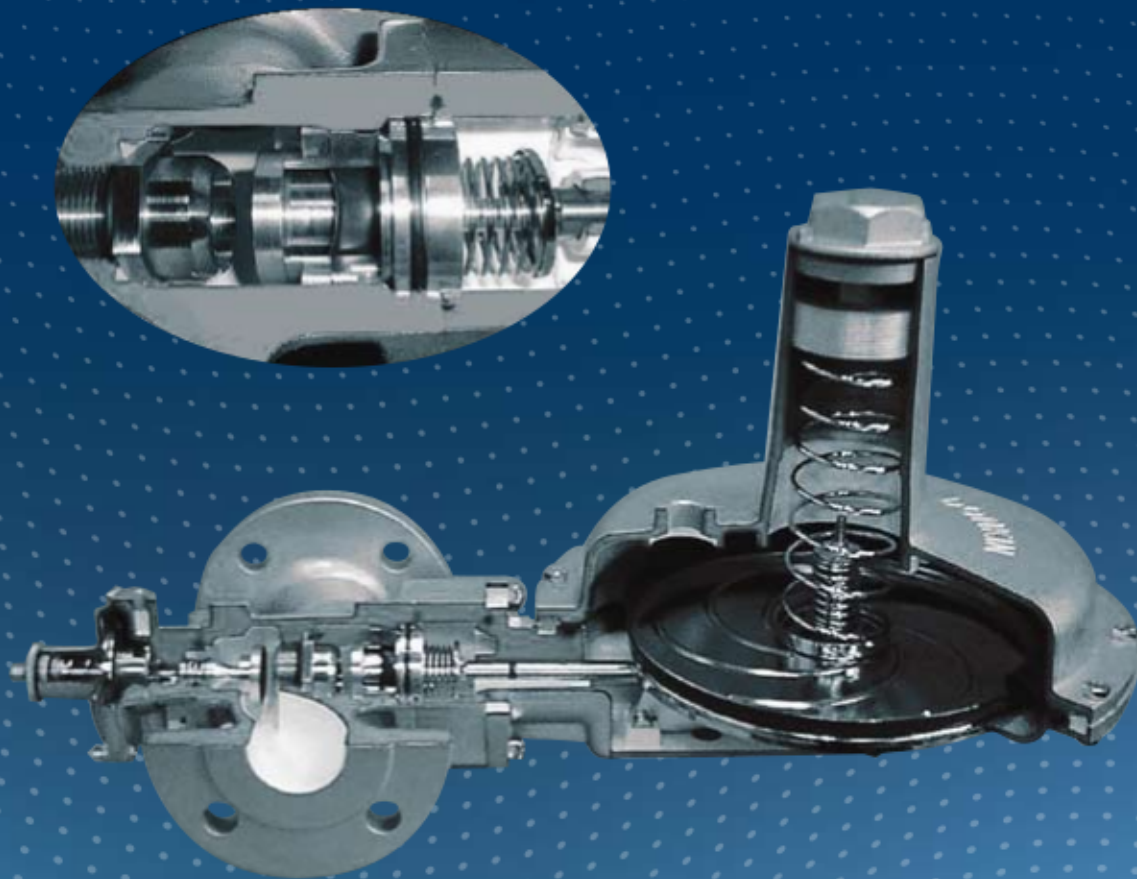

PRODUCT INFORMATION

**Serving the Gas Industry
Worldwide**



CONTROLS SUPPLY CHAIN
VALVES ACTUATORS INSTRUMENTATIONS



GAS PRESSURE REGULATOR SERIES 277 HI-FLO™

Introduction, Application, Features, Technical Data

Introduction

- The Series 277 & 277H 'Hi-Flo' Regulators are direct acting, single main diaphragm, spring loaded open, balanced, lever operated regulators for use on pressure reduction systems. Designed to control a wide inlet pressure and capacity applications by utilising a pressure balancing secondary diaphragm.
- Use with confidence on natural and manufactured gases of non-aggressive nature, including Nitrogen, Carbon Dioxide, Propane and Butane.

Application

- Designed for use on gas pressure reduction services to domestic, business premises and industrial feeds to burners, heater units and boilers
- For equipment where an accurate, safe, dependable pressure controlled supply is required.

Features

- Completely independent operation of regulator and safety cut-off valve.
- Diaphragm casing may be rotated through steps of 45 deg. relative to body to give the optimum installed position.
- Cartridge construction, servicing and inspection can be carried out without taking body out of the line.
- Wide inlet and outlet pressure range achieved by a middle balancing diaphragm and interchangeable main springs.
- External Pressure Impulse (Rc 1/2 connection).
- With or without Internal Relief Valve.

TECHNICAL DATA	
Size range: DN 50	Flanged BS 4504 PN16 and ASA Class 150
Service conditions: Maximum inlet pressure	10.3 Barg (149 psig)
Outlet Pressure Range: Series 277 Series 277H	10 to 350 mbarg (4 to 140" wg) 320 to 500 mbarg (128 to 200" wg)
Maximum Incidental Outlet Pressure: Series 277 Series 277H	550 mbarg (220" wg) } 700 mbarg (280" wg) } (i.e. Max. Allowable OPCO trip set pressure)
Internal Relief Valve Setting: Series 277 Series 277H	20 mbarg (8" wg) } 80 mbarg (32" wg) } Nominally (above regulator outlet pressure set-point)
Temperature Range	-20°C to +60°C
Options • P - Type • R - Type	No Internal Relief With Internal Relief
<ul style="list-style-type: none"> • Regulator can be fitted with the Series 309 Over pressure (OPCO), or Under/Over pressure (UPCO/OPCO), Safety Cut-Off Valve. These devices protect the downstream system in the event that an excessive gas pressure condition develops. • Trip Indicator to show Open/Closed condition 	

Installation

- The regulator may be mounted in any orientation to suit site conditions, moisture or debris must not ingress the vent hole.
- For optimum performance the recommended position is with diaphragm casing horizontal and spring housing vertically upwards.
- It is important when installing equipment that pipeline stresses are kept to a minimum and no undue external forces are placed on the connections.



GAS PRESSURE REGULATOR SERIES 277 HI-FLO™

Technical Data

TECHNICAL DATA					
Regulator Spring Ranges		Spring		Outlet pressure range	
		Number	Colour	mbar	ins wg
* Series 277H model only, requires special spring adjuster, spring carrier, top cap and internal relief spring.		1244	Red	10 - 15	4 - 6
		1245	Grey	15 - 20	6 - 8
		1299	Purple	18 - 35	7 - 14
		1246	Green	20 - 28	8 - 11
		1247	Yellow	28 - 45	11 - 18
		1248	Black	45 - 75	18 - 30
		1249	White	75 - 110	30 - 44
		1250	Orange	95 - 150	38 - 60
		1251	Blue	140 - 225	56 - 90
		1252	Silver	200 - 350	80 - 140
		1263*	Brown	320 - 500	128 - 200
		1253	Test Spring for elevated outlet pressures to facilitate OPCO setting.		
LP-OPCO: Safety Cut-Off Valve		Spring		Pressure cut-off range	
		Number	Colour	mbar	ins wg
		* Requires special spacer.		861	Brown
		1103	Gold	80 - 130	32 - 52
		1104	Purple	120 - 250	48 - 100
		1105	Black	200 - 350	80 - 140
		1254*	Red	340 - 500	136 - 200
		1255*	Green	450 - 600	180 - 240
LP-UPCO/OPCO: Safety Cut-Off Valve	OPCO	1109	Grey	40 - 55	16 - 22
	OPCO	1110	Green	50 - 110	20 - 44
	OPCO	1111	Silver	110 - 200	44 - 80
	OPCO	1140	Silver/Red	150 - 240	60 - 96
	UPCO	1138	Blue/Green	10 - 30	4 - 12
MP2 - OPCO and UPCO/OPCO: Safety Cut-Off Valve	OPCO	1132	White/Blue	500 - 800	200 - 320
	UPCO	1104	Purple	50 - 190	20 - 76
Materials of Construction	Regulator	Body Top & Bottom Half Casing, Top Cap, Spring Adjuster (Series 277) Spring Carrier, Top Cap (Series 277H) Orifice, Bottom Casing Guide Bush Lever Valve Spindle Spring Retainer and Diaphragm Plates Relief Valve & Main Springs Valve Seat 'O' Rings Diaphragms Balancing Cartridge		Ductile Iron: BS EN 1563 Grade EN-GJS-18-LT Aluminium Alloy: BS 1490 Grade Gr. LM24M Mild Steel: BS 970 Grade 070M20 plated Brass: BS 2874 Grade CZ 121 Stainless Steel: BS 3416 Grade ANC 3B Stainless Steel: BS 970 Grade 416S29 Mild Steel: BS 1449 Grade CS4 plated Spring Carbon Steel: BS 5216 Grade HS3 and Chrome Vanadium: BS 2803 Polyurethane Nitrile Moulded Nylon Reinforced Nitrile Aluminium: BS 1474 Grade 6082	
	Safety Cut-Off Valve	Body Spindle Valve Valve Seating Diaphragm & 'O' Rings Spring Adjuster Spring		Aluminium: BS 1490 LM6 Stainless Steel: BS 970 Grade 316 S31 Aluminium: BS 1474 Grade 6082TF Polyurethane Nitrile Brass: BS 2874 Grade CZ 121 Spring Carbon Steel: BS 5216 Grade HS3	

Minimum OPCO & UPCO/OPCO Settings:

- P - Type: 35 mbar (14" wg) or 10% above regulator set-point, whichever is the higher.
- R - Type: 55 mbar (22" wg), when Internal Relief fitted.
- Minimum differential pressure between UPCO and OPCO is 45mbar (18" wg) for P - Type and 65mbar (26" wg) for R - Type with internal relief.
- Maximum recommended OPCO setting above Regulator Set-Point is 200 mbar (80" wg).



GAS PRESSURE REGULATOR SERIES 277 HI-FLO™

Performance

TABLE OF COEFFICIENTS				
Orifice Size (mm)	Body Size	Cg	K1	C1
32mm	DN 50	809	83	41

Note $C_v = \frac{C_g}{C_1}$

Capacity Performance

- For in-control capacities see capacity tables given on page 5.
- Maximum full open capacities can be calculated using the following equations:

Sub-Critical Flow

- $(P_e - P_a) \leq 0.5(P_e + P_b)$

$$Q = \frac{6.97}{\sqrt{d(te + 273)}} C_g (P_e + P_b) \sin \left[K_1 \sqrt{\frac{P_e - P_a}{P_e + P_b}} \right] \text{ deg}$$

Critical Flow

- $(P_e - P_a) \geq 0.5(P_e + P_b)$

$$Q = \frac{6.97}{\sqrt{d(te + 273)}} C_g (P_e + P_b)$$

Example Calculation : For 2" size with 32mm orifice

Conditions : Inlet Pressure (Pe) 1 barg
 : Outlet Pressure (Pa) 200 mbarg
 Medium : Natural Gas SG 0.6

Test for flow conditions: $(1 - 0.2) \leq 0.5(1 + 1.01325)$
 $0.8 \leq 1.006$

*Hence Sub-Critical Flow conditions.

Full Open Capacity:

$$Q = \frac{6.97}{\sqrt{0.6(15 + 273)}} \times 809(2.01325) \sin \left[83 \sqrt{\frac{0.8}{2.01325}} \right] \text{ deg}$$

Q=682 Sm³/hr

Performance Classification

- Lock Up (SG): The amount of 'Lock-Up' pressure is dependant upon the main spring fitted and the prevailing inlet pressure ranges.
- Accuracy Class (AC): All capacity data given in the tables is based on AC10 and AC20
- Flow Turn Down Ratio: Varies according to prevailing pressure, flow and installation design. For a general guide expect 50:1 minimum.

DEFINITION	
Q	Full Open Capacity in m ³ /hr at Metric Standard Conditions (M.S.C.)
Cg	Flow Coefficient
K1	Body Shape Factor
d	Relative Density/SG of Gas (Air = 1)
Pe	Inlet Pressure (bar g)
Pa	Outlet Pressure (bar g)
Pb	Ambient atmospheric pressure in barA (Absolute)
te	Gas temperature at inlet of unit in °C
6.97	Constant
M.S.C.	Absolute pressure of 1.01325 barA and temperature of 15°C

Internal relief

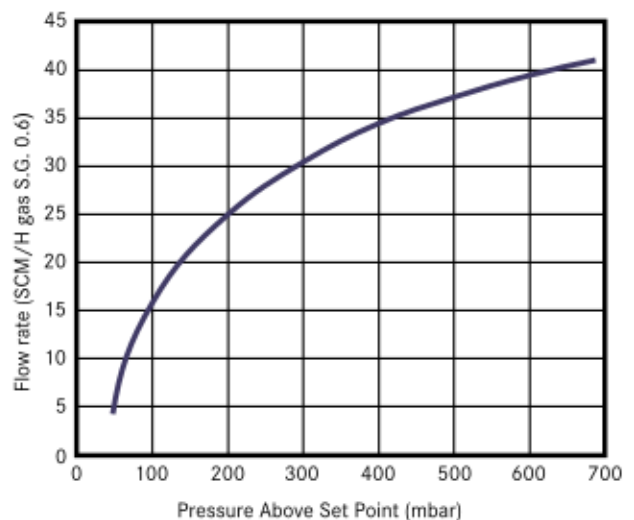



GAS PRESSURE REGULATOR SERIES 277 HI-FLO™

Capacities: DN 50 in sm³/hr for Natural Gas (SG 0.6)

ACCURACY CLASS AC10										
Inlet Pressure	Lock Up Pressure Class (SG)									
	SG30	SG30	SG30	SG30	SG20	SG20	SG20	SG15	SG15	SG15
	Spring Number									
	1244	1245	1246	1247	1248	1249	1250	1251	1252	1263
	Set Point pas (mbar)									
	14	17	25	32	55	85	135	200	290	475
70 mbar	100	90	85	75	-	-	-	-	-	-
140 mbar	140	140	140	125	105	80	-	-	-	-
350 mbar	225	225	225	210	200	185	185	165	100	-
700 mbar	340	340	400	330	300	280	280	280	280	250
1 bar	400	500	510	400	400	400	400	400	375	350
2 bar	600	700	700	650	650	650	650	650	650	600
3 bar	800	900	1000	1000	1000	1000	1000	1000	900	800
4 bar	1250	1250	1250	1250	1250	1250	1250	1250	1200	1100
5 bar	1600	1600	1600	1600	1600	1600	1600	1600	1500	1400
6 bar	1850	1850	1850	1850	1850	1850	1850	1725	1600	1500
7 bar	2225	2225	2225	2225	2225	2225	2225	2125	2000	1850
8 bar	2600	2600	2600	2600	2600	2600	2600	2450	2300	2150
9 bar	2900	2900	2900	2900	2900	2900	2900	2700	2500	2350
10 bar	3350	3350	3350	3350	3350	3350	3350	3150	2900	2700

5

ACCURACY CLASS AC20										
Inlet Pressure	Lock Up Pressure Class (SG)									
	SG30	SG30	SG30	SG30	SG20	SG20	SG20	SG15	SG15	SG15
	Spring Number									
	1244	1245	1246	1247	1248	1249	1250	1251	1252	1263
	Set Point pas (mbar)									
	14	17	25	32	55	85	135	200	290	475
70 mbar	125	115	115	85	-	-	-	-	-	-
140 mbar	175	175	175	175	175	175	-	-	-	-
350 mbar	275	275	275	275	275	300	325	325	300	-
700 mbar	375	400	450	450	450	475	500	450	400	350
1 bar	500	550	550	550	550	580	620	600	550	500
2 bar	750	800	850	850	850	950	1050	1000	950	900
3 bar	1125	1220	1300	1300	1300	1375	1450	1400	1350	1300
4 bar	1700	1700	1700	1700	1700	1800	1900	1800	1700	1650
5 bar	2100	2100	2100	2100	2100	2250	2400	2250	2100	2050
6 bar	2250	2250	2250	2325	2400	2575	2750	2525	2300	2250
7 bar	2600	2600	2600	2750	2900	3000	3100	2900	2700	2650
8 bar	3100	3100	3100	3250	3250	3375	3500	3250	3000	2900
9 bar	3400	3400	3400	3500	3600	3800	4000	3700	3400	3300
10 bar	3800	3800	3800	3900	4000	4250	4500	4150	3800	3700

* CAPACITY TABLES (In accordance with Specification BS EN 334)

Types of Gases

The capacities given in the tables are given in terms of natural gas (SG 0.6). For all other gases multiply by the following correction factor:

$$\sqrt{\frac{0.6}{\text{SG of gas handled}}}$$



GAS PRESSURE REGULATOR SERIES 277 HI-FLO™

Dimensions & Weights

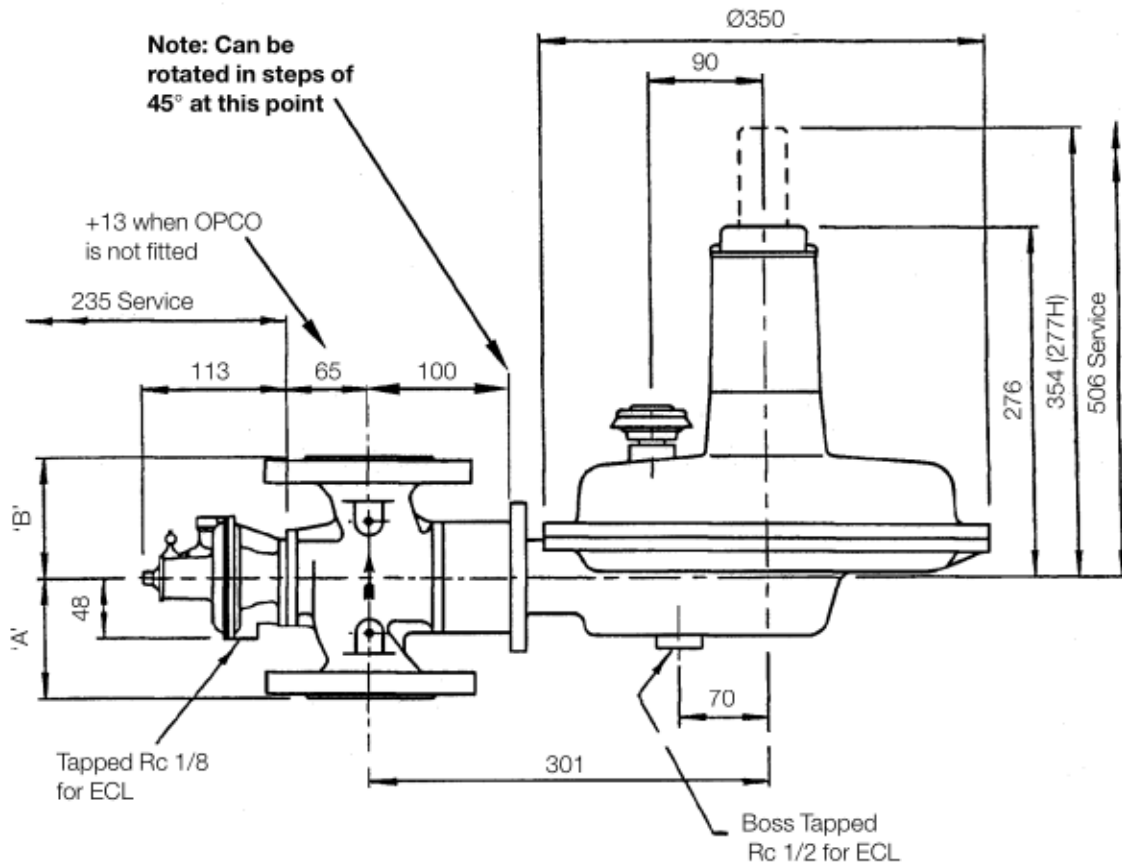

DIMENSIONS & WEIGHTS						
			277		277H	
Size	'A'	'B'	Wt. with OPCO kg	Wt. No OPCO kg	Wt. with OPCO kg	Wt. No OPCO kg
DN 50 Flanged	95	95	17	16.5	18	17.5

All dimensions in mm



GAS PRESSURE REGULATOR SERIES 277 HI-FLO™

Sectional Arrangement

Series 277R - 309 - OPCO

