



## Angle Safety Valve

# S3000

**Maximum Pressure**  
**420 Barg**

**Temperature**  
**-268/+540°C**

**ST-105E Rev.0.1**



*The S3000 angle safety valves have flanged connections in accordance with ASME B16.5.*

*They are suitable to be used with fluids / gases and steam from -268°C up to 540°C. The stem is guided at the top and the disc has the blow-down ring.*

*A balanced bellows is provided for backpressures exceeding 10% of the set pressure.*

*The S3000 valves are designed according to API 526 and comply with the 97/23/EC (PED) cat.IV and ATEX Standards requirements.*



### Materials

<b>Body/Bonnet</b>	A216WCB A351CF8/CF8M/WC6/LCB
<b>Trim</b>	AISI 316 / 304
<b>Stem</b>	AISI 304
<b>Seal</b>	Metallic
<b>Bellows</b>	AISI 316
<b>Spring</b>	AISI 316

### Operating Conditions

<b>PMO</b>	Max Operative Pressure 420 Barg
<b>TMO</b>	Max Operative Temperature -268/+540°C

### Accessories

- Test gag
- Lever with or without packing
- Balanced bellows
- Jacket
- Open/Closed Bonnet

### Applications

- Suitable for cryogenic fluids
- Liquid Oxygen -268°C
- Liquid Nitrogen -268°C
- Air
- LPG & LNG

### Characteristics

- |  |  |  |
|--|--|--|
| <ul style="list-style-type: none"> <li>• Angle body</li> <li>• Blow-down ring</li> <li>• Suitable for liquids, gas and steam</li> <li>• Stem /Plug Guided</li> </ul> | <ul style="list-style-type: none"> <li>• Flanged Connections</li> <li>• Max. inlet rating ANSI 2500 (PN.400)</li> <li>• Max. outlet rating ANSI 600 (PN.63)</li> </ul> | <ul style="list-style-type: none"> <li>• Orifice from D to T</li> <li>• API 526</li> <li>• PED 97/23/CE Cat. IV</li> <li>• ATEX 94/9/CE II – 2G</li> <li>• K Coefficient = 0,93 GAS</li> </ul> |
|--|--|--|



## S3000 - Angle Safety Valve

### Models/Connections

**S3011-31-51** 3/4" x 1"  
D - 150,300,600 x 150

**S3011-31-51** 1" x 2"  
D - 150,300,600 x 150

**S3011-31-51** 1 1/2" x 2"  
D - 900,1500 x 300

**S3082** 1 1/2" x 2 1/2"  
D - 2500 x 300

**S3011-31-51** 1" x 2"  
E - 150,300,600x 150

**S3062-72** 1 1/2" x 2"  
E - 900,1500 x 300

**S3082** 1 1/2" x 2 1/2"  
E - 2500 x 300

**S3011-31-51** 1 1/2" x 2"  
F - 150,300,600 x 150

**S3062-72-82** 1 1/2" x 2 1/2"  
F - 900,1500,2500 x 300

**S3011-31-51** 1 1/2" x 2 1/2"  
G - 150,300,600 x 150

**S3062-72-82** 2" x 3"  
G - 900,1500,2500 x 300

**S3011** 1 1/2" x 3"  
H - 150 x 150

**S3031-51** 2" x 3"  
H - 300,600 x 150

**S3062-72** 2" x 3"  
H - 900,1500 x 300

**S3011-31** 2" x 3"  
J - 150,300 x 150

**S3051** 2 1/2" x 4"  
J - 600 x 300

**S3062-72** 3" x 4"  
J - 900,1500 x 150,300

**S3011-31-51** 3" x 4"  
K - 150,300,600 x 150

**S3062-72** 3" x 6"  
K - 900,1500 x 150,300

**S3011-31** 3" x 4"  
L - 150,300 x 150

**S3031-51-61-71** 4" x 6"  
L - 300,600,900,1500 x 150

**S3011-31-51-61** 4" x 6"  
M - 150,300,600,900 x 150

**S3011-31-51-61** 4" x 6"  
N - 150,300,600,900 x 150

**S3011-31-51-61** 4" x 6"  
P - 150,300,600,900 x 150

**S3011-31-51** 6" x 8"  
Q - 150,300,600 x 150

**S3011-31-51** 6" x 8"  
R - 150,300,600 x 150

**S3031-51** 6" x 10"  
R - 300,600 x 150

**S3011-31** 8" x 12"  
T - 150,300 x 150

**S3031-51** 8" x 12"  
T - 300,600 x 150

### Overall Dimensions and Technical Characteristic

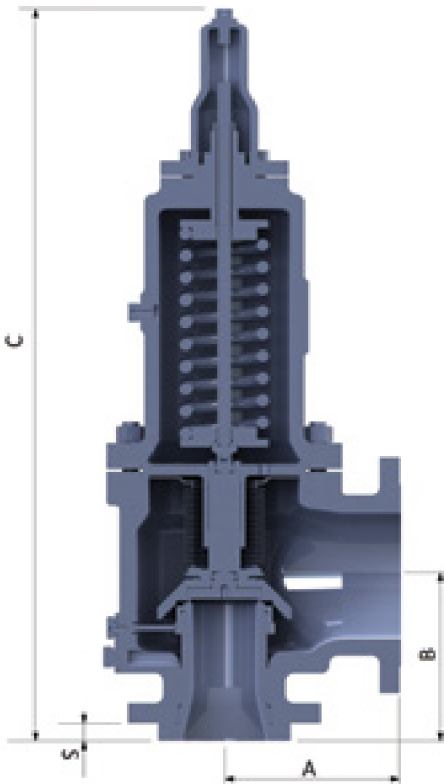

FLANGED VALVES S. 3000

TYPE	ORIFICE AREA (*)		Ø ORIFICE (*)		TYPE	ORIFICE AREA (*)		Ø ORIFICE (*)	
	cm <sup>2</sup>	sq. inc.	mm	inc.		cm <sup>2</sup>	sq. inc.	mm	inc.
D	0.785	0.121	10	0.393	L	21.65	3.355	52.5	2.066
E	1.390	0.215	13.3	0.523	M	25.3	3.921	56.8	2.236
F	2.16	0.335	16.6	0.653	N	30.5	4.73	62.4	2.456
G	3.53	0.547	21.2	0.834	P	45	6.97	75.7	2.980
H	5.51	0.855	26.5	1.043	Q	77.9	12.06	99.6	3.921
J	9.07	1.405	34	1.338	R	112.7	17.42	119.8	4.716
K	12.9	2.003	40.6	1.598	T	183.3	28.4	152.8	6.015

(\*) The values for the areas specified here are the actual ones measured by NCC during the time approval phase. The values indicated in the selection tables are the theoretical ones in accordance with the API 526 standards.

### Special Design

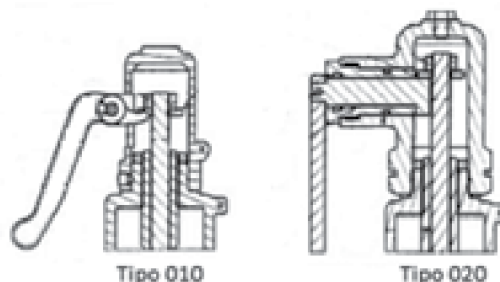



## S3000 - Angle Safety Valve

### Overall Dimensions and Technical Characteristic

TIPO	ATTACCHI - CONNECTIONS			RATINGS		Alzata Lift	DIMENSIONI DI INGOMBRO - OVERALL DIMENSIONS					PESO-WEIGHT Kg.
	TYPE	Entr. Inlet	O	Usc. Outlet	Entr. Inlet		Usc. Outlet	A	B	C	CL	
3011 - D	¾"	D	1"	150	150	2,5	100	85	340	360	24	20
3031 - D	¾"	D	1"	300	150		100	85	340	360	24	20
3051 - D	¾"	D	1"	600	150		100	85	340	360	24	20
3011 - D	1"	D	2"	150	150		115	105	405	405	32	22
3031 - D	1"	D	2"	300	150		115	105	405	405	32	22
3051 - D	1"	D	2"	600	150		115	105	405	405	32	22
3062 - D	1 1/2"	D	2"	900	300		125	127	475	500	43	35
3072 - D	1 1/2"	D	2"	1500	300		125	127	475	500	43	35
3082 - D	1 1/2"	D	2 1/2"	2500	300		150	147	495	525	55	43
3011 - E	1"	E	2"	150	150	3,4	115	105	405	405	32	22
3031 - E	1"	E	2"	300	150		115	105	405	405	32	22
3051 - E	1"	E	2"	600	150		115	105	405	405	32	22
3062 - E	1 1/2"	E	2"	900	300		125	127	475	500	43	35
3072 - E	1 1/2"	E	2"	1500	300		125	127	475	500	43	35
3082 - E	1 1/2"	E	2 1/2"	2500	300		150	147	495	525	55	43
3011 - F	1 1/2"	F	2"	150	150	4,5	121	124	475	500	37	24
3031 - F	1 1/2"	F	2"	300	150		121	124	475	500	37	24
3051 - F	1 1/2"	F	2"	600	150		121	124	475	500	39	24
3062 - F	1 1/2"	F	2 1/2"	900	300		150	127	475	500	43	40
3072 - F	1 1/2"	F	2 1/2"	1500	300		150	127	475	500	43	40
3082 - F	1 1/2"	F	2 1/2"	2500	300		150	147	495	525	55	45
3011 - G	1 1/2"	G	2 1/2"	150	150	6,5	121	124	475	500	37	28
3031 - G	1 1/2"	G	2 1/2"	300	150		121	124	475	500	37	28
3051 - G	1 1/2"	G	2 1/2"	600	150		121	124	475	500	39	28
3061 - G	1 1/2"	G	2 1/2"	900	300		150	127	475	500	43	40
3062 - G	2"	G	3"	900	300		165	160	695	695	49	42
3072 - G	2"	G	3"	1500	300		165	161	695	695	50	42
3082 - G	2"	G	3"	2500	300	170	165	720	780	67	50	
3011 - H	1 1/2"	H	3"	150	150	7,5	124	134	540	565	36	32
3031 - H	2"	H	3"	300	150		124	134	540	565	39	32
3051 - H	2"	H	3"	600	150		124	134	540	565	39	36
3062 - H	2"	H	3"	900	150		165	167	695	695	55	42
3072 - H	2"	H	3"	1500	300		165	161	695	695	50	42
3011 - J	2"	J	3"	150	150	11	124	134	540	565	36	32
3031 - J	2"	J	3"	300	150		124	134	540	565	39	32
3031 - J	2 1/2"	J	4"	300	150		165	156	710	710	46	50
3051 - J	2 1/2"	J	4"	600	300		165	156	710	710	46	50
3062 - J	3"	J	4"	900	150		190	178	730	730	51	65
3072 - J	3"	J	4"	1500	300		190	178	760	760	61	65



## S3000 - Angle Safety Valve

### Overall Dimensions and Technical Characteristic

TIPO	ATTACCHI - CONNECTIONS			RATINGS		Alzata	DIMENSIONI DI INGOMBRO - OVERALL DIMENSIONS					PESO-WEIGHT
	TYPE	Entr. Inlet	O	Usc. Outlet	Entr. Inlet	Usc. Outlet	Lift	A	B	C	CL	S
3011-K	3"	K	4"	150	150	12	165	156	710	710	41	60
3031-K	3"	K	4"	300	150		165	156	710	710	46	65
3051-K	3"	K	4"	600	150		165	156	710	710	49	65
3062-K	3"	K	6"	900	150		210	205	920	920	55	110
3072-K	3"	K	6"	1500	300		210	205	920	920	57	110
3011-L	3"	L	4"	150	150	18	165	156	710	710	41	60
3031-L	3"	L	4"	300	150		165	156	710	710	46	65
3031-L	4"	L	6"	300	150		210	196	865	865	45	95
3051-L	4"	L	6"	600	150		210	196	865	865	47	115
3061-L	4"	L	6"	900	150		210	196	865	865	53	135
3071-L	4"	L	6"	1500	150	210	210	865	965	70	145	
3031-M	4"	M	6"	300	150	21	210	196	865	865	45	110
3051-M	4"	M	6"	600	150		210	196	865	865	47	130
3061-M	4"	M	6"	900	150		210	196	865	865	53	150
3011-N	4"	N	6"	150	150	21	210	196	865	865	45	110
3031-N	4"	N	6"	300	150		210	196	865	865	45	125
3051-N	4"	N	6"	600	150		210	196	865	865	47	150
3061-N	4"	N	6"	900	150		210	196	865	865	53	190
3011-P	4"	P	6"	150	150	23,5	210	196	865	865	45	115
3031-P	4"	P	6"	300	150		210	196	865	865	45	130
3051-P	4"	P	6"	600	150		210	196	865	865	47	180
3061-P	4"	P	6"	900	150		210	196	865	865	53	200
3011-Q	6"	Q	8"	150	150	29	250	240	1055	1055	47	210
3031-Q	6"	Q	8"	300	150		250	240	1055	1055	51	230
3051-Q	6"	Q	8"	600	150		250	260	1055	1055	58	270
3011-R	6"	R	8"	150	150	36	250	240	1055	1055	47	230
3031-R	6"	R	8"	300	150		250	240	1055	1055	51	260
3031-R	6"	R	8"	300	150		267	240	1055	1055	58	280
3051-R	6"	R	8"	600	150		267	240	1055	1055	58	300
3031-R	6"	R	10"	300	150		267	240	1055	1055	58	280
3051-R	6"	R	10"	600	150		267	240	1055	1055	58	300
3011-T	8"	T	10"	150	150	45	290	284	1180	1180	55	330
3031-T	8"	T	10"	300	150		290	284	1180	1180	55	350
3031-T	8"	T	12"	300	150		290	284	1180	1180	56	350
3051-T	8"	T	12"	600	150		290	284	1190	1190	67	360