



## Technical Data Sheet Type 26

- 2/2-way pressure operated valve
- NC - Valve normally closed (as standard)
- NO - Valve normally open (as option)
- DW - Valve with double acting actuator (as option)

Force-pilot operated piston design valve. No differential pressure is necessary for operation. In standard (NC) the valve closes with spring power.

■ Valve for clean, gaseous and liquid media

### TECHNICAL SPECIFICATIONS

Type of control	Pressure operated
Design	Piston design
Connection	Flanges DN15 - DN300 EN 1092-1 Form B1/B2
Installation	Preferable with actuator upright
Pressure	0 - 40 bar (see table on page 2)
Medium	Clean, neutral, gaseous and liquid media
max. viscosity	22 mm <sup>2</sup> /s
Temperature range	Medium: -40 °C up to +200 °C Ambient: -10 °C up to +60 °C
Body material	Spheroidal cast EN-GJS-400-18-LT Cast iron EN-GJL-250 Cast steel GP240 GH Stainless steel 1.4581 / 1.4408
Metallic inner parts	Brass and Stainless steel
Sealing	NBR, FKM, EPDM, PTFE
Pilot pressure	4 - 10 bar max pressure with at least 6 bar
Pilot medium	Clean, neutral gases

Pilot valve	<b>2/131-31-1702-C182</b>
-------------	---------------------------



3/2-way direct operated, NC  
G1/8, orifice 1.5mm, 0-8 bar  
Aluminum / Stainless steel / FKM  
with Cnomo-coil as well as with  
integrated screw connection for  
easy assembly

	<b>A7231/1002/....</b>
--	------------------------



3/2-way direct operated, NC  
G1/8, orifice 1.5mm, 0-8 bar  
brass / st. steel / FKM

### VALVE FEATURES

- No pressure difference required
- High life time
- Simple compact valve design
- Reliable and sturdy sealing elements
- Long-term availability of spare parts

### FUNCTION

NC – non  
pressurized  
closed

NO – non  
pressurized open

DW - double  
acting

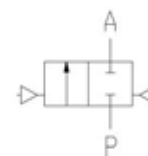
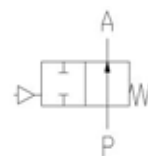
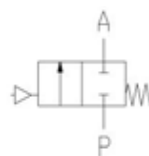

### CERTIFICATES



### ORDERING SYSTEM

Type	Conn.	Housing	Seal	Actuator	Option
. 2 6	0 9	/ 0 4	0 4	/ 7 0 0 8	- H A
01 DN15 02 DN20 03 DN25 04 DN32 05 DN40 06 DN50 07 DN65 08 DN80 09 DN100 10 DN125 11 DN150 12 DN200 13 DN250 14 DN300		03 EN-GJS-400-18-LT 04 EN-GJL-250 05 GP240 GH 08 St. steel 1.4408	01 NBR 02 FKM 04 PTFE 06 EPDM	7 . Normally closed 8 . Normally open 9 . Double acting . 0 Standard actuator . 3 Act. Stainless steel . 5 Act. chem. nickel pl.	. 5 50 mm . 8 80 mm . 3 125 mm



## TECHNICAL FEATURES

DN	Kv-value m³/h	Standard type	max. pressure with actuator		
			7.05	7.08	7.13
15	6,8	.2601/..04/	0-40	-	-
20	8,8	.2602/..04/	0-40	-	-
25	11,5	.2603/..04/	0-40	-	-
32	18,0	.2604/..04/	0-16	0-40	-
40	26,0	.2605/..04/	0-16	0-40	-
50	38,0	.2606/..04/	0-16	0-40	-
65	62,0	.2607/..04/	0-16	0-40	-
80	89,0	.2608/..04/	0-16	0-40	-
100	125,0	.2609/..04/	-	0-40	-
125	265,0	.2610/..04/	-	0-40	-
150	377,0	.2611/..04/	-	0-16	0-40
200	667,0	.2612/0304/	-	0-16	-
250	a.Anfr.	.2613/0304/	-	0-16	-
300	a.Anfr.	.2614/0304/	-	0-16	-

The flow rate mentioned in the table applies to the most strongest actuator  
Pressure range for cast iron EN-GJL-250 is max. 13 bar.

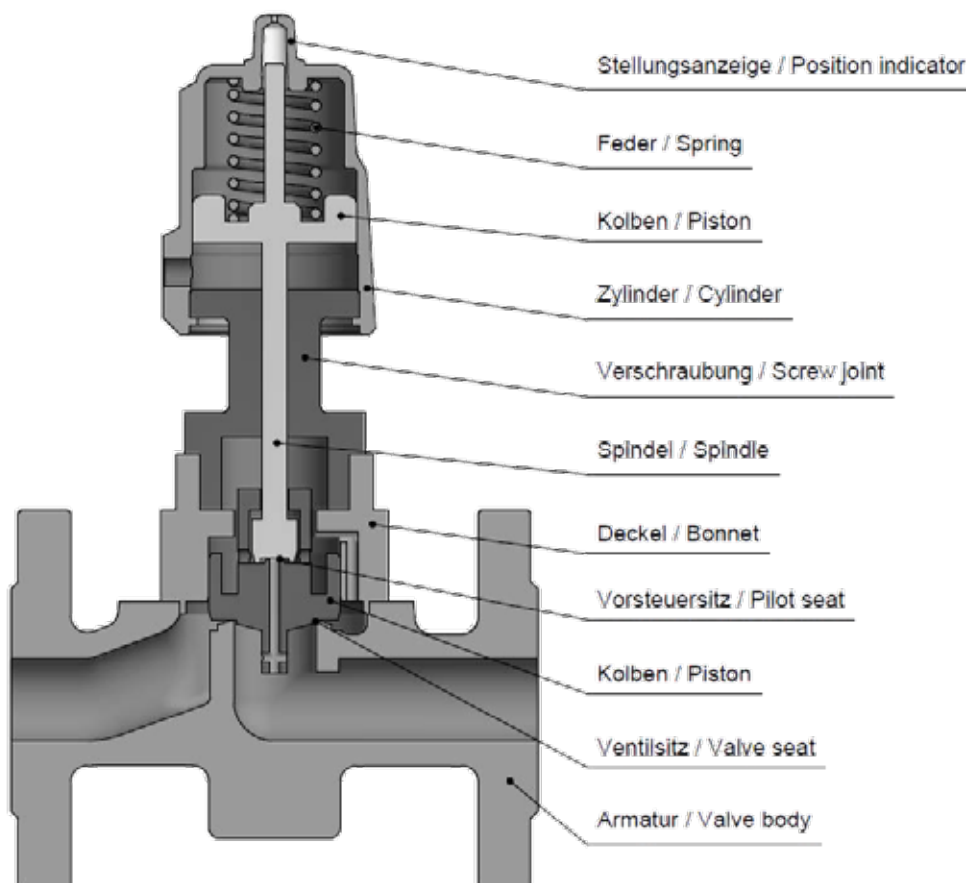

# DIMENSIONS

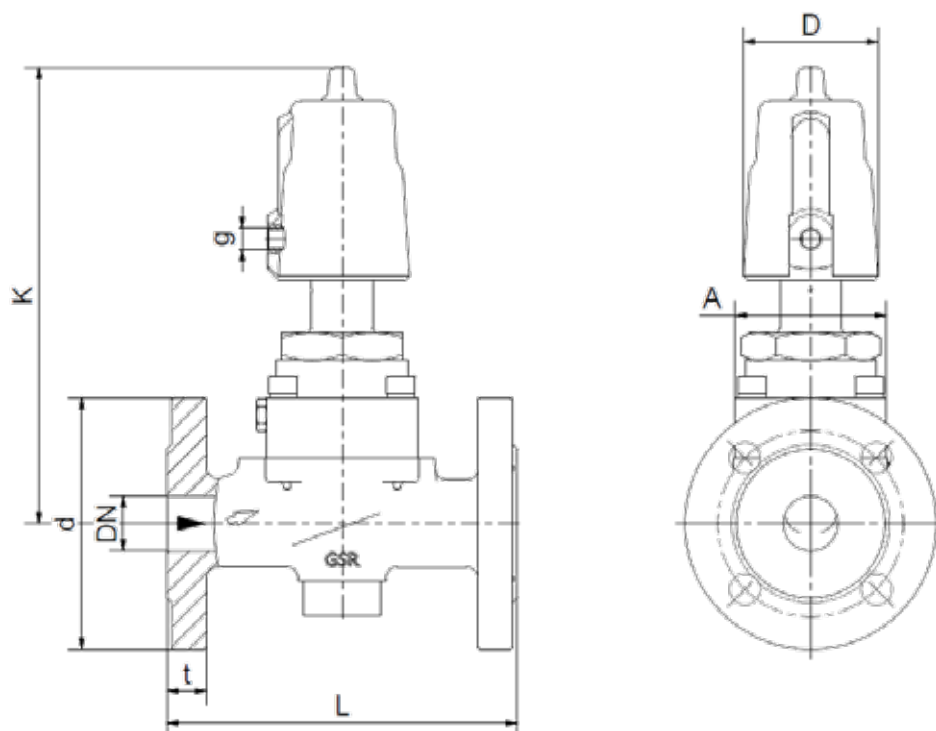

Type 26

Actuator	7005								
Type	2601	2602	2603	2604	2605	2606	2607	2608	2609
DN	15	20	25	32	40	50	65	80	100
A	48 (44)	70 (69)	70 (69)	98	98	112	215 (180)	245	on req.
d	95	105	115	140	150	165	185	200	220
D	62	62	62	62	62	62	62	62	62
K	220 (215)	223 (220)	225 (220)	245 (230)	250 (235)	240 (240)	285 (265)	290	on req.
L	130	150	160	180	200	230	290	310	350
g	1/8	1/8	1/8	1/8	1/8	1/8	1/8	1/8	1/8
t	16	18	18	18	18	20	22	24	24
kg	4,5 (3,6)	6,0	6,0	10,5 (9,0)	11,0	12,5	23,5 (26)	31,0	on req.

The values in brackets refer to the stainless steel version (DN15 - DN100)

Actuator	7008								7013
Type	2604	2605	2606	2607	2608	2609	2610	2611	2611
DN	32	40	50	65	80	100	125	150	150
A	98	98	112	215	245	270	235	265	on req.
d	140	150	165	185	200	235	270	300	300
D	94	94	94	94	94	94	94	94	141
K	290 (280)	290 (280)	300 (275)	330 (405)	295	315	350	395	on req.
L	180	200	230	290	310	350	400	480	480
g	1/8	1/8	1/8	1/8	1/8	1/8	1/8	1/8	1/4
t	18	18	20	22	24	24	26	28	28
kg	11,0	11,5	13,5 (12)	25,5 (28)	34,0	48,5	53,5	75,0	on req.

The values in brackets refer to the stainless steel version (DN15 - DN100)



## INFORMATION

- It is imperative to observe the installation and safety instructions in our operating and service manuals.
- For information on our GSR ordering code, please refer to our catalogs. If you have any questions, we will be glad to assist you.
- Required ordering information: valve type, function NC/NO, pressure range, connection, nominal width, medium, flow rate, medium and ambient temperatures, connection voltage.
- **Detailed production-specific drawings and other technical information will be made available when an order is placed**

## PLEASE NOTE

Each individual application decides which valve type is required, the main factor being the resistance of the materials to the operating medium. The correct selection of materials requires knowledge of the concentration, temperature and degree of contamination of the medium. Other criteria include the operating pressure and max. volumetric flow, since , in addition to high temperatures , high pressures and high flow rates must also be taken into account when selecting the materials.

**All materials used for our valves, be it housing, seals or magnets, will be carefully selected in view of the different application areas. Any information given is non-binding and serves for orientation only. No claims under warranty can be derived therefrom.**

- The GSR logo is a registered trademark of GSR Ventiltechnik GmbH & Co. KG.
- Note: All texts and images are the property of GSR Ventiltechnik GmbH & Co. KG and must not be replicated or modified, not even in part, without written approval.
- Original products may differ from the product images shown, due to different materials and the like.
- Subject to error and changes.

**Status: 03.20, MK-MG, V1**