



Technical Data Sheet Type 22

- 2/2-way pressure operated valve
- NC - Valve normally closed (as standard)
- NO - Valve normally open (as option)
- DW - Valve with double acting actuator (as option)

Direct pressure controlled valve. The valve seat is opened against a spring force via the control medium.

■ Valve for clean, gaseous and liquid media

TECHNICAL SPECIFICATIONS

Type of control	Direct pressure operated
Design	Poppet design
Connection	Flanged DN15 - DN200 EN 1092-1 Form B1/B2
Installation	Preferable with actuator upright
Pressure	0 - 40 bar (see table on page 2)
Medium	Clean, neutral, gaseous and liquid media
max. viscosity	600 mm ² /s
Temperature range	Medium: -40 °C up to +200 °C Ambient: -10 °C up to +60 °C
Body material	Cast iron EN-GJL-240 Cast steel GP240 GH Spheroidal cast EN-GJS-400-18-LT Stainless steel 1.4408
Metallic inner parts	Brass and Stainless steel
Sealing	PTFE, FKM, EPDM
Pilot pressure	4 - 10 bar max pressure with at least 6 bar
Pilot medium	Clean and neutral gases Other pilot media on request

Pilot valve	2/131-31-1702-C182
-------------	---------------------------



3/2-way direct operated, NC
G1/8, orifice 1.5mm, 0-8 bar
Aluminum / Stainless steel / FKM
with Chomo-coil as well as with
integrated screw connection for
easy assembly

	A7231/1002/....
--	------------------------



3/2-way direct operated, NC
G1/8, orifice 1.5mm, 0-8 bar
Brass / Stainless steel / FKM

VALVE FEATURES

- No pressure difference required
- High life time
- Simple compact valve design
- Reliable and sturdy sealing elements
- Long-term availability of spare parts

FUNCTION

NC – non
pressurized
closed

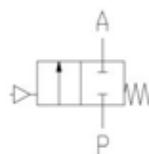

NO – non
pressurized open

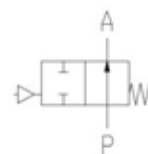

DW - double
acting

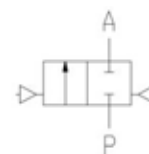

CERTIFICATES



ORDERING SYSTEM

Type	Conn.	Housing	Seal	Actuator
. 2 2	0 6	/ 0 4	0 4	/ 7 0 0 8
01 DN15 02 DN20 03 DN25 04 DN32 05 DN40 06 DN50 07 DN65 08 DN80 09 DN100 10 DN125 11 DN150 12 DN200		03 EN-GJS-400-18-LT 04 EN-GJL-250 05 GP240 GH 08 Edelstahl 1.4408	02 FKM 04 PTFE 06 EPDM	7 . Normally closed 8 . Normally open 9 . Double acting . 0 Standard actuator . 3 Act. Stainless steel . 5 Act. chem. nickel pl. . 5 50 mm . 8 80 mm . 3 125 mm

TECHNICAL FEATURES

Type 22

DN	Kv-value m³/h	Standard type	max. pressure with actuator					
			7.05		7.08		7.13	
			Cast iron	Cast steel St. steel	Cast iron	Cast steel St. steel	Cast iron Spher. cast	Cast steel St. steel
15	6,8	.2201/..04/	-	0-20	-	0-40	-	-
20	6,8	.2202/..04/	0-13	0-12	-	0-25	-	-
25	11,0	.2203/..04/	0-13	0-13	0-13	0-25	-	-
32	18,0	.2204/..04/	0-5	0-5	0-13	0-14	-	-
40	27,0	.2205/..04/	0-5	0-5	0-13	0-14	-	-
50	43,0	.2206/..04/	0-3	0-3	0-9	0-9	0-13	0-20
65	71,0	.2207/..04/	-	-	0-6	0-6	0-13	0-15
80	111,0	.2208/..04/	-	-	0-4	0-4	0-10	0-10
100	173,0	.2209/..04/	-	-	0-2,5	0-2,5	0-6	0-6
125	on req.	.2210/0304/	-	-	-	-	0-4,5	-
150	on req.	.2211/0304/	-	-	-	-	0-3	-
200	on req.	.2212/0304/	-	-	-	-	0-1,5	-

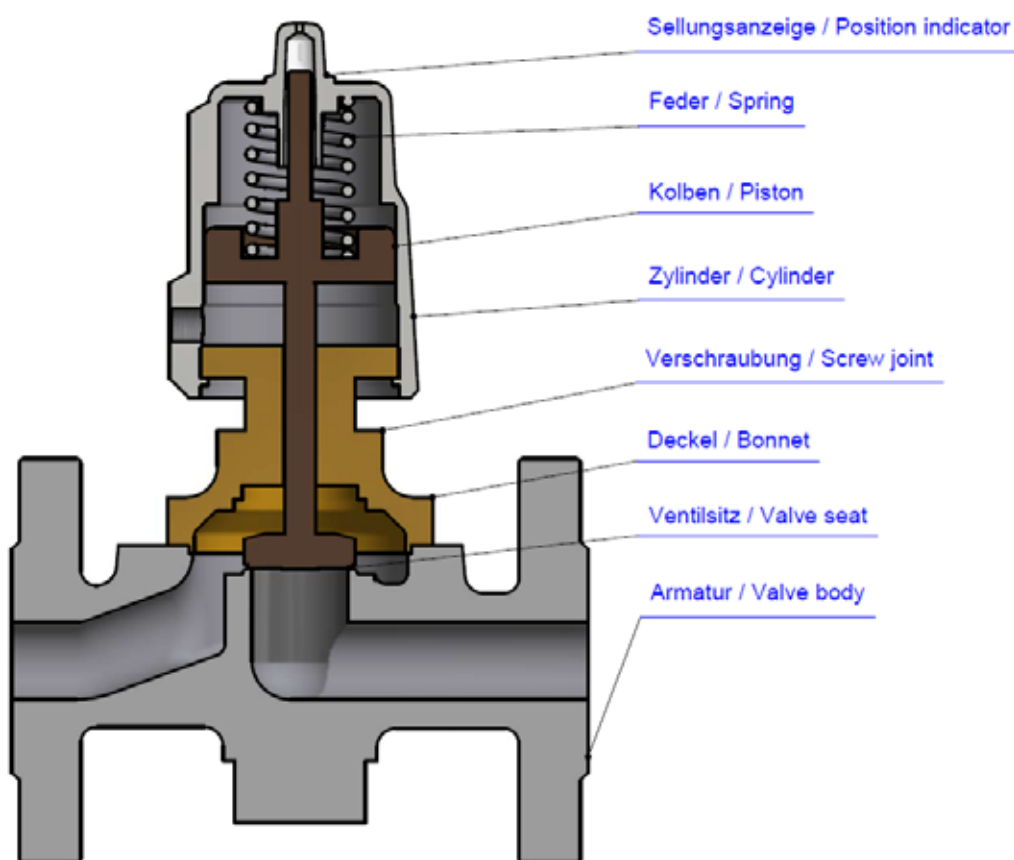

DIMENSIONS

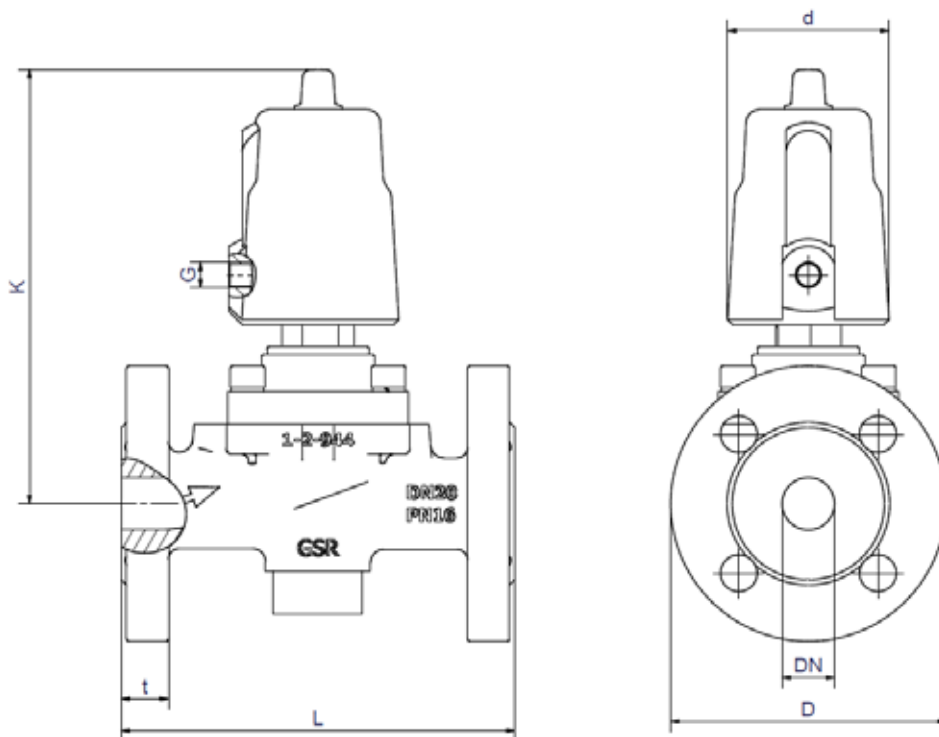

Actuator	7005						7008			
Type	2201	2202	2203	2204	2205	2206	2201	2202	2203	2204
DN	15	20	25	32	40	50	15	20	25	32
d	62	62	62	62	62	62	94	94	94	94
G	1/8	1/8	1/8	1/8	1/8	1/8	1/8	1/8	1/8	1/8
K	178	182	182	208	208	209	235	231	232	245
D	95	105	115	140	150	165	95	105	115	140
L	130	150	160	180	200	230	130	150	160	180
t	16	18	18	18	18	20	16	18	18	18
kg	3,5	4,7	5,4	8,2	8,7	11,8	3,8	5,1	5,7	8,3

Different dimension K with body EN-GJL-250

Actuator	7008					7013						
Type	2205	2206	2207	2208	2209	2206	2207	2208	2209	2210	2211	2212
DN	40	50	65	80	100	50	65	80	100	125	150	200
d	94	94	94	94	94	141	141	141	141	141	141	141
G	1/8	1/8	1/8	1/8	1/8	1/4	1/4	1/4	1/4	1/4	1/4	1/4
K	245	256	270	283	303	339	347	359	382	407	439	531
D	150	165	185	200	235	165	185	200	220	250	285	340
L	200	230	290	310	350	230	290	310	350	400	480	600
t	18	20	20	25	25	20	19	21	24	26	26	32
kg	8,8	12,0	15,8	22,0	30,2	13,7	25,3	24,8	39,5	11,6	24,5	105,1

Different dimension K with body EN-GJL-250



INFORMATION

- It is imperative to observe the installation and safety instructions in our operating and service manuals.
- For information on our GSR ordering code, please refer to our catalogs. If you have any questions, we will be glad to assist you.
- Required ordering information: valve type, function NC/NO, pressure range, connection, nominal width, medium, flow rate, medium and ambient temperatures, connection voltage.
- **Detailed production-specific drawings and other technical information will be made available when an order is placed**

PLEASE NOTE

Each individual application decides which valve type is required, the main factor being the resistance of the materials to the operating medium. The correct selection of materials requires knowledge of the concentration, temperature and degree of contamination of the medium. Other criteria include the operating pressure and max. volumetric flow, since , in addition to high temperatures , high pressures and high flow rates must also be taken into account when selecting the materials.

All materials used for our valves, be it housing, seals or magnets, will be carefully selected in view of the different application areas. Any information given is non-binding and serves for orientation only. No claims under warranty can be derived therefrom.

- The GSR logo is a registered trademark of GSR Ventiltechnik GmbH & Co. KG.
- Note: All texts and images are the property of GSR Ventiltechnik GmbH & Co. KG and must not be replicated or modified, not even in part, without written approval.
- Original products may differ from the product images shown, due to different materials and the like.
- Subject to error and changes.

Stand: 12.17, MK-MG, Version 1.