



## Technical Data Sheet Type 3/045

3/2-way Solenoid valve  
UN - Universal design

Direct operated Design. No differential pressure is necessary for operation. When energized, the valve seat is opened directly.

In standard (NC) the valve closes with spring power.

■ Solenoid valve for high pressure applications

Type 3/045

### TECHNICAL SPECIFICATIONS

Type of control	Direct operated
Design	Poppet design
Connection	Threaded G1/8 - G1/2 DIN ISO 228/1 (BSP) Further connections like NPT on request
Installation	With actuator upright
Pressure	0 - 250 bar (see table on page 2)
Medium	Clean, neutral, gaseous and liquid media
max. viscosity	22 mm <sup>2</sup> /s
Temperature range	Medium: -10 °C up to +80 °C Ambient: -10 °C up to +50 °C In consideration of the restrictions described on page 4
Body material	Stainless steel 1.4571
Metallic inner parts	Brass and Stainless steel
Sealing	PEEK
Supply voltage	AC~ 24V, 110V, 230V DC= 12V, 24V Other supply voltages on request
Voltage tolerance	-10% / +10%
Power consumption	.272 = 100 Watt    .278 = 47 Watt ⚡ .352 = 150 Watt    .358 = 75 Watt ⚡
Protection class	IP65 acc. to DIN 60529
Duty factor	100% ED-VDE 0580
Connection type	Terminal box
Ex-proof	acc. to 2014/34/EU (ATEX) Further Ex-proof on request

### VALVE FEATURES

- For high pressure applications up to 250 bar
- No pressure difference required
- High life time
- High-quality materials
- Reliable and sturdy sealing elements

### FUNCTION

NC – non pressurized closed    NO – non-pressurized open

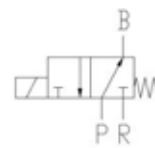
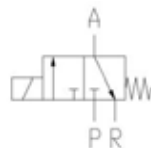

### CERTIFICATES



### ORDERING SYSTEM

Type	Connect.	Housing	Seal	Actuator
3 / 0 4 5	- 2 3	- 0 8	1 5	- . 2 7 2
	20 G 1/8 21 G 1/4 22 G 3/8 23 G 1/2	08 St. steel 1.4571	15 PEEK	2 Standard IP65 8 Explosion proof acc. to directive 2014/34/EU (ATEX)

# TECHNICAL FEATURES

Type 3/045

G	Seat Ø mm	Kv-value m³/h	Standard type	max. pressure for coils		max. pressure for coils ATEX	
				.272	.352	.278	.358
1/8	10,0	1,2	3/045-20-0815-	0-200	0-250	0-150	0-210
1/4	10,0	1,2	3/045-21-0815-	0-200	0-250	0-150	0-210
3/8	10,0	1,2	3/045-22-0815-	0-200	0-250	0-150	0-210
1/2	10,0	1,2	3/045-23-0815-	0-200	0-250	0-150	0-210

The flow rate mentioned in the table applies to the strongest coil.

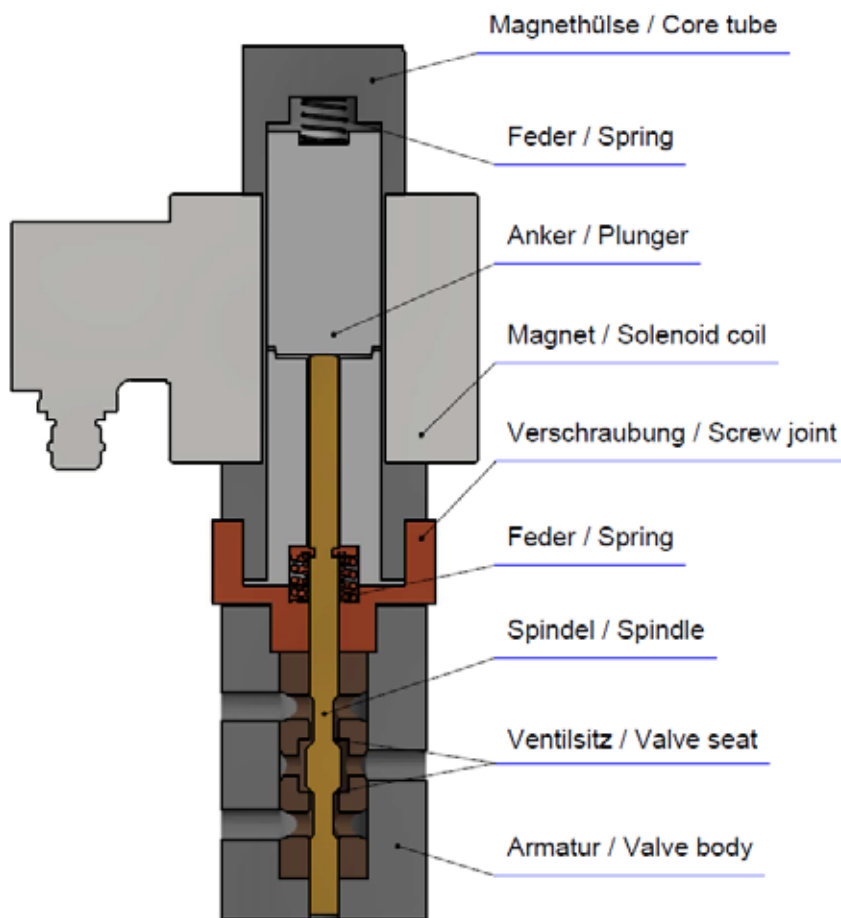

## DIMENSIONS

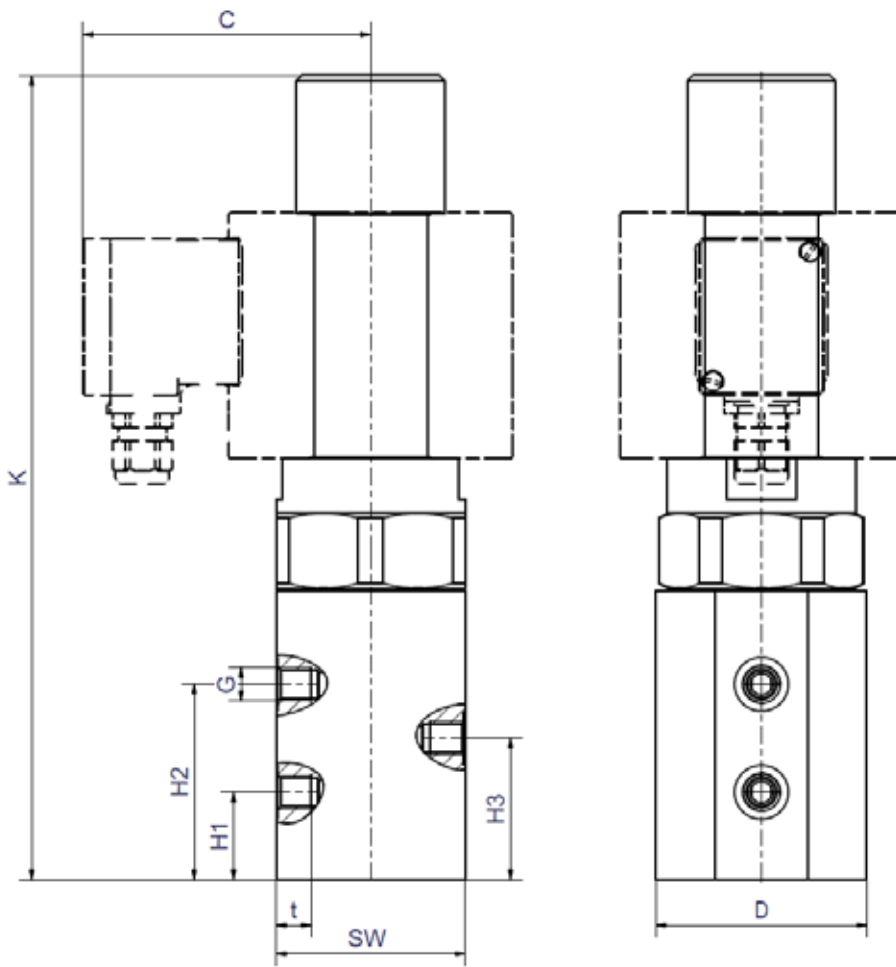

Coil	.272 / .278				.352 / .358			
Type	3/045-20	3/045-21	3/045-22	3/045-23	3/045-20	3/045-21	3/045-22	3/045-23
G	1/8	1/4	3/8	1/2	1/8	1/4	3/8	1/2
C	107	107	107	107	127	127	127	127
K	299	299	299	299	332	332	332	332
D	78	78	78	78	78	78	78	78
SW	70	70	70	70	70	70	70	70
H1	32,5	32,5	32,5	32,5	32,5	32,5	32,5	32,5
H2	72,5	72,5	72,5	72,5	72,5	72,5	72,5	72,5
H3	52,5	52,5	52,5	52,5	52,5	52,5	52,5	52,5
t	12,5	13,0	13,0	15,0	12,5	13,0	13,0	15,0
kg	10,9	11,3	11,2	10,8	22,6	22,6	22,6	22,5



## INFORMATION

- It is imperative to observe the installation and safety instructions in our operating and service manuals.
- For information on our GSR ordering code, please refer to our catalogs. If you have any questions, we will be glad to assist you.
- Required ordering information: valve type, function NC/NO, pressure range, connection, nominal width, medium, flow rate, medium and ambient temperatures, connection voltage.
- **Detailed production-specific drawings and other technical information will be made available when an order is placed**

## PLEASE NOTE

Each individual application decides which valve type is required, the main factor being the resistance of the materials to the operating medium. The correct selection of materials requires knowledge of the concentration, temperature and degree of contamination of the medium. Other criteria include the operating pressure and max. volumetric flow, since, in addition to high temperatures, high pressures and high flow rates must also be taken into account when selecting the materials.

**All materials used for our valves, be it housing, seals or magnets, will be carefully selected in view of the different application areas. Any information given is non-binding and serves for orientation only. No claims under warranty can be derived therefrom.**

## Heating and power of solenoid coils

The GSR default solenoid valves are designed for continuous operation (100% ED = power-on time) under normal operating conditions. The pulling force of a solenoid coil is basically influenced by three elements:

- The self-heating of the magnetic coil
- The medium temperature
- The ambient temperature

GSR solenoid coils are by default designed for a maximum ambient temperature of +35 °C. This specification applies for the maximum allowable operating pressure specified in the data sheet of the corresponding valve, 100% duty cycle and a medium temperature of +80 °C.

A higher ambient temperature is possible, when lower values are applied for the other influencing parameters. When the max. operation pressure and max. ambient temperature of +50 °C is given the medium temperature is not allowed to be higher than max. +50 °C. In addition to that, deviations from the default design temperature range are possible, e.g. when temperature coils or other constructive measures are used. Please contact the GSR headquarters to discuss the specific application.

More precise specifications and technical data with regard to the operating conditions can be found in the data sheets of the solenoid coils and the solenoid valve regarded. Please observe that the surface temperature of a permanently loaded coil can amount up to +120 °C, solely by the self-heating of the coil. The power consumption of our default solenoid valves was calculated to DIN VDE 05820 for a coil temperature of +20 °C.

- The GSR logo is a registered trademark of GSR Ventiltechnik GmbH & Co. KG.
- Note: All texts and images are the property of GSR Ventiltechnik GmbH & Co. KG and must not be replicated or modified, not even in part, without written approval.
- Original products may differ from the product images shown, due to different materials and the like.
- Subject to error and changes.

**Stand: 04.18, MK-MG, Version 1.**