



Technical Data Sheet Type 48FL

2/2-way solenoid valve
NC - Valve normally closed (as standard)
NO - Valve normally open (as option)

Direct operated poppet design valve. No differential pressure is necessary for operation. When energized, the valve seat is opened directly.
In standard (NC) the valve closes with spring power.

■ Solenoid valve for gaseous and liquid media

Type 48FL

TECHNICAL SPECIFICATIONS

Type of control	Direct operated, no differential pressure necessary
Design	Poppet design
Connection	Flanges DN15 - DN80 EN 1092-1 Form B1/B2 Larger nominal sizes on request
Installation	With actuator upright
Pressure	0 - 3 bar (see table on page 2)
Medium	Clean, neutral, gaseous and liquid media
max. viscosity	22 mm ² /s
Temperature range	Medium: -10 °C up to +80 °C Ambient: -10 °C up to +50 °C <small>In consideration of the restrictions described on page 4</small>
Body material	Stainless steel 1.4408
Metallic inner parts	Stainless steel
Sealing	NBR, FKM, EPDM
Supply voltage	AC~ 24V, 110V, 230V DC= 12V, 24V <small>Other supply voltages on request</small>
Voltage tolerance	-10% / +10%
Power consumption	.012 = 18 Watt .148 = 10 Watt ☹️ .802 = 24 Watt .808 = 24 Watt ☹️ .322 = 30 Watt .328 = 24 Watt ☹️ .242 = 46 Watt .248 = 30 Watt ☹️ .272 = 100 Watt .278 = 47 Watt ☹️ .352 = 150 Watt .358 = 75 Watt ☹️
Protection class	IP65 acc. to DIN 60529
Duty factor	100% ED-VDE 0580
Connection type	Plug, Terminal box
Ex-proof	acc. to 2014/34/EU (ATEX) <small>Further Ex-proof on request</small>

VALVE FEATURES

- No pressure difference required
- High life time
- Simple compact valve design
- Reliable and sturdy sealing elements
- Long-term availability of spare parts

FUNCTION

NC – non energized closed NO – non-energized open

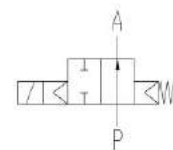
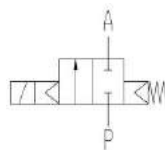

CERTIFICATES



ORDERING SYSTEM

Type	Conn.	Housing	Seal	Coil	Option
4	8	2	5	0	8
0	8	0	1	2	4
2	4	2	-	F	L
23 DN15		08 St. steel 1.4408	01 NBR	2 Standard IP65	FL DIN flanged
24 DN20			02 FKM	8 Explosion proof acc. to directive 2014/34/EU (ATEX)	AF ANSI flanged
25 DN25			04 PTFE		
26 DN32			06 EPDM		
27 DN40					
28 DN50					
29 DN65					
30 DN80					

TECHNICAL FEATURES

DN	Seat Ø mm	Kv-value m³/h	Standard type	max. pressure for coils					
				.012-FL	.802-FL	.322-FL	.242-FL	.272-FL	.352-FL
15	12,5	3,2	.4823/0801/	0-0,5	0-1	0-3	-	-	-
20	18	4,9	.4824/0801/	0-0,1	0-0,4	0-1	0-2	-	-
25	24	8,5	.4825/0801/	-	0-0,2	0-0,5	0-1	0-2	-
32	29	15,0	.4826/0801/	-	-	0-0,3	0-0,5	0-1	-
40	35	20,0	.4827/0801/	-	-	-	0-0,3	0-0,5	-
50	45	30,0	.4828/0801/	-	-	-	0-0,15	0-0,3	0-0,8
65	62	58,0	.4829/0801/	-	-	-	-	0-0,15	0-0,4
80	75	60,0	.4830/0801/	-	-	-	-	0-0,1	0-0,3

The flow rate mentioned in the table applies to the strongest coil.

DN	Seat Ø mm	Kv-value m³/h	Standard type	max. pressure for coils ATEX 🚫					
				.148-FL	.808-FL	.328-FL	.248-FL	.278-FL	.358-FL
15	12,5	3,2	.4823/0801/	0-0,2	0-1	0-1	-	-	-
20	18	4,9	.4824/0801/	-	0-0,4	0-0,5	0-1,2	-	-
25	24	8,5	.4825/0801/	-	0-0,2	0-0,5	0-0,7	0-1	-
32	29	15,0	.4826/0801/	-	-	0-0,2	0-0,3	0-0,5	-
40	35	20,0	.4827/0801/	-	-	-	0-0,2	0-0,3	-
50	45	30,0	.4828/0801/	-	-	-	-	0-0,2	0-0,4
65	62	58,0	.4829/0801/	-	-	-	-	-	0-0,15
80	75	60,0	.4830/0801/	-	-	-	-	-	0-0,15

The flow rate mentioned in the table applies to the strongest coil.

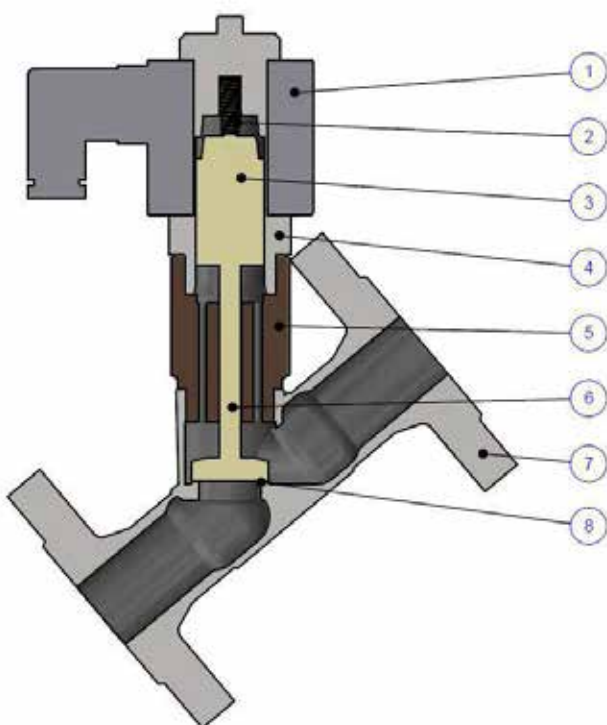

Description	
1	Solenoid coil
2	Spring
3	Plunger
4	Tube
5	Spacer
6	Spindle
7	Valve body
8	Valve seat



Type 48FL

DIMENSIONS

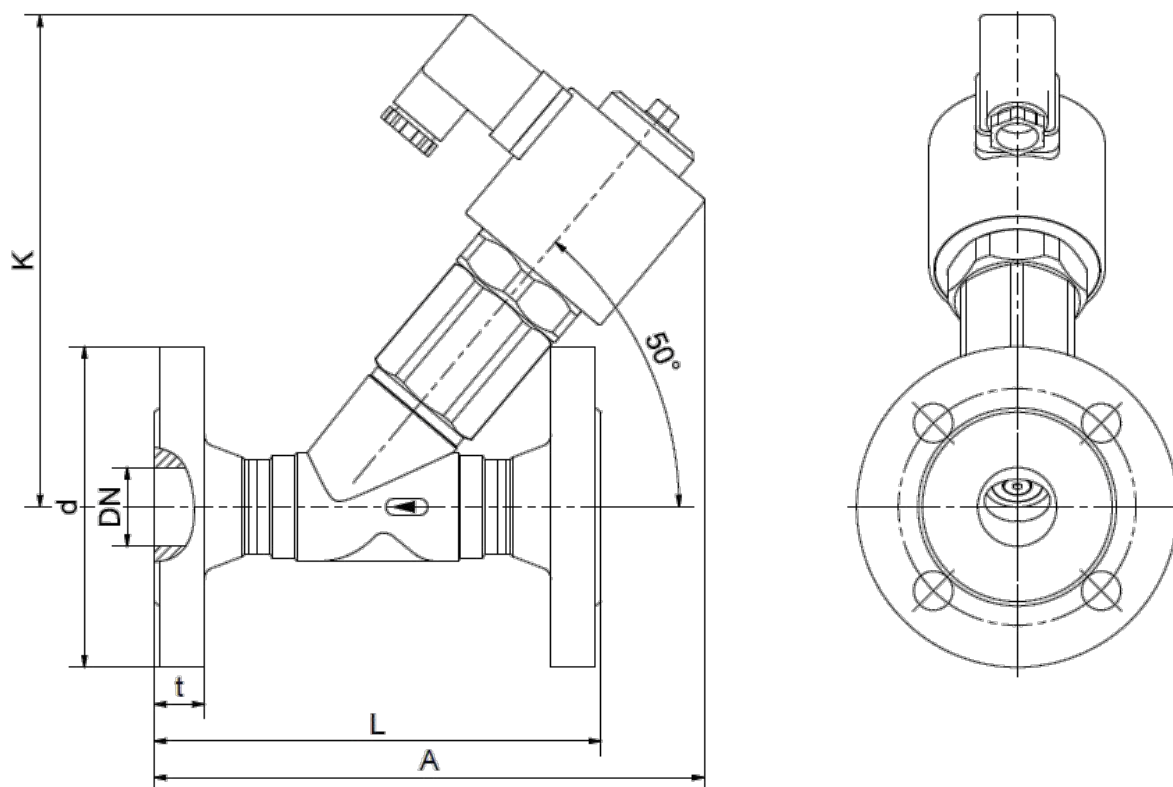

Coil	.012 / .148*		.802 / .808*			.322 / .328*				.242 / .248		
Type	.4823	.4824	.4825	.4826	.4827	.4823	.4824	.4825	.4826	.4824	.4825	.4826
DN	15	20	15	20	25	15	20	25	32	20	25	32
A	150	150	178	187	187	194	204	198	210	228	232	245
C	61	61	70	70	70	77	77	77	77	93	93	93
d	95	105	95	105	115	95	105	115	140	105	115	140
K	135	120	167	169	165	185	187	177	185	220	223	233
L	130	150	130	150	160	130	150	160	180	150	160	180
t	16	18	16	18	18	16	18	18	18	18	18	18
kg	2,3	3,1	2,8	3,5	4,1	3,5	4,3	5,1	6,0	5,8	6,6	8,0

*Differing dimension "K" for ATEX-coils

Coil	.242 / .248		.272 / .278					.352 / .358			
Type	.4827	.4828	.4825	.4826	.4827	.4828	.4829*	.4830*	.4828	.4829*	.4830*
DN	40	50	25	32	40	50	65	80	50	65	80
A	240	256	262	275	287	290	-	-	on req	-	-
C	93	93	107	107	107	107	107	107	127	127	127
d	150	165	115	140	150	165	185	200	165	185	200
K	215	223	250	260	265	255	on req	on req	on req	on req	on req
L	200	230	160	180	200	230	290	310	230	290	310
t	18	20	18	18	18	20	22	24	20	22	24
kg	9,0	11,0	10,2	11,7	12,7	14,7	on req	on req	on req	on req	on req

* .4807 and .4808 with straight seated body design



INFORMATION

- It is imperative to observe the installation and safety instructions in our operating and service manuals.
- For information on our GSR ordering code, please refer to our catalogs. If you have any questions, we will be glad to assist you.
- Required ordering information: valve type, function NC/NO, pressure range, connection, nominal width, medium, flow rate, medium and ambient temperatures, connection voltage.
- **Detailed production-specific drawings and other technical information will be made available when an order is placed**

PLEASE NOTE

Each individual application decides which valve type is required, the main factor being the resistance of the materials to the operating medium. The correct selection of materials requires knowledge of the concentration, temperature and degree of contamination of the medium. Other criteria include the operating pressure and max. volumetric flow, since, in addition to high temperatures, high pressures and high flow rates must also be taken into account when selecting the materials.

All materials used for our valves, be it housing, seals or magnets, will be carefully selected in view of the different application areas. Any information given is non-binding and serves for orientation only. No claims under warranty can be derived therefrom.

Heating and power of solenoid coils

The GSR default solenoid valves are designed for continuous operation (100% ED = power-on time) under normal operating conditions. The pulling force of a solenoid coil is basically influenced by three elements:

- The self-heating of the magnetic coil
- The medium temperature
- The ambient temperature

GSR solenoid coils are by default designed for a maximum ambient temperature of +35 °C. This specification applies for the maximum allowable operating pressure specified in the data sheet of the corresponding valve, 100% duty cycle and a medium temperature of +80 °C.

A higher ambient temperature is possible, when lower values are applied for the other influencing parameters. When the max. operation pressure and max. ambient temperature of +50 °C is given the medium temperature is not allowed to be higher than max. +50 °C. In addition to that, deviations from the default design temperature range are possible, e.g. when temperature coils or other constructive measures are used. Please contact the GSR headquarters to discuss the specific application.

More precise specifications and technical data with regard to the operating conditions can be found in the data sheets of the solenoid coils and the solenoid valve regarded. Please observe that the surface temperature of a permanently loaded coil can amount up to +120 °C, solely by the self-heating of the coil. The power consumption of our default solenoid valves was calculated to DIN VDE 05820 for a coil temperature of +20 °C.

- The GSR logo is a registered trademark of GSR Ventiltechnik GmbH & Co. KG.
- Note: All texts and images are the property of GSR Ventiltechnik GmbH & Co. KG and must not be replicated or modified, not even in part, without written approval.
- Original products may differ from the product images shown, due to different materials and the like.
- Subject to error and changes.

Stand: 01.20, MK-MG, Version 1.