



Technical Data Sheet Type 91K

2/2-Way solenoid valve
Valve normally closed (NC).
When energized the solenoid first opens the pilot hole and then lifts directly or supported by a pressure difference the piston from the valve seat. The valve is closed by spring power.

■ Solenoid valve for cryogenic fluids

Type 91K

TECHNICAL SPECIFICATIONS VALVE FEATURES

Type of control:	Force pilot operated, no pressure difference required
Design:	Piston design
Connection:	Threaded G1/4-G2 DIN ISO 228 (BSP), Welding ends similar to ISO 4200 (see table page 4) Other connections like NPT on request
Installation:	Actuator in upright position Lying position of actuator on request
Pressure:	0-16 bar (see table page 2)
Medium:	Clean, neutral, gaseous and liquid medium
Viscosity:	22 mm ² /s
Temperature range:	Medium: -196 °C up to +80 °C Ambient: -55 °C up to +50 °C In consideration of the restrictions described on page 4
Body material:	Brass 2.0402 Stainless steel 1.4581
Metallic inner parts:	Brass and stainless steel
Sealing:	PTFE
Supply voltage:	AC~ 24V, 110V, 230V DC= 12V, 24V, 110V Other supply voltages on request
Voltage tolerance:	-10% / +10%
Power consumption:	W802 = 24 Watt W322 = 30 Watt .242 = 46 Watt .272 = 100 Watt
Protection class:	IP65 according to DIN EN 60529
Duty factor:	100% ED DIN VDE 0580
Connection type:	Terminal box

- Low temperature design -196 °C
- No pressure difference is required
- High life time
- Simple compact valve design
- Reliable and sturdy sealing elements
- Long-term availability of spare parts
- High-quality materials
- NO (non energized open) on request
- AS (Welding ends)

FUNCTION

NC - non energized closed

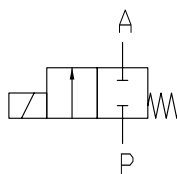

NO - non energized open

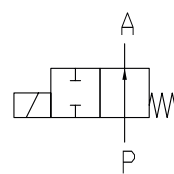

ORDERING SYSTEM

				Coil system		Valve options	
K	91	23	/	08	04	/	W 80 2 - A S
		Connection		Body			Coil system
		21 G ¹ / ₄		08 Stainless steel 1.4581		.	Standard (with Terminal box)
		22 G ³ / ₈		10 Brass		W	Design with Terminal box
		23 G ¹ / ₂		Seal		2	Standard IP65
		24 G ³ / ₄		04 PTFE			
		25 G ¹					
		26 G ¹ / ₄					
		27 G ¹ / ₂					
		28 G ²					
							Valve options
							AS
							Welding ends similar to ISO 4200



TECHNICAL FEATURES

G	Seat ø mm	Kv-value m ³ /h	Standard type	max. pressure			
				W802	W322	.242	.272
1/4	13,5	1,8	K9121/..04/...	0-16*	-	-	-
3/8	13,5	4,0	K9122/..04/...	0-16*	-	-	-
1/2	13,5	4,5	K9123/..04/...	0-16*	-	-	-
3/4	27,5	11,5	K9124/..04/...	-	0-16*	-	-
1	27,5	13,0	K9125/..04/...	-	0-16*	-	-
1 1/4	40,0	29,0	K9126/..04/...	-	0-10	0-16*	-
1 1/2	40,0	33,0	K9127/..04/...	-	0-10	0-16*	-
2	50,0	49,0	K9128/..04/...	-	0-6	0-16	0-16*

The flow rate mentioned in the table applies to the *marked coil.

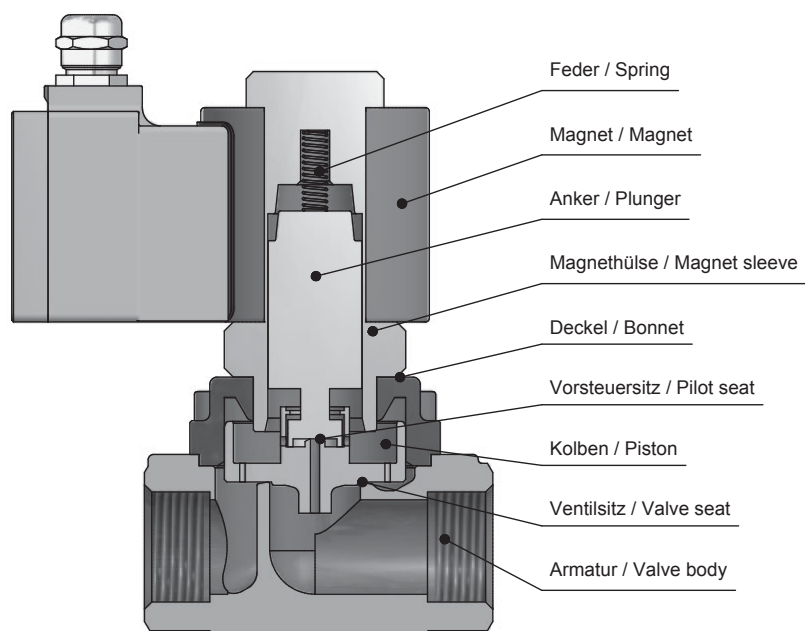



DIMENSIONS

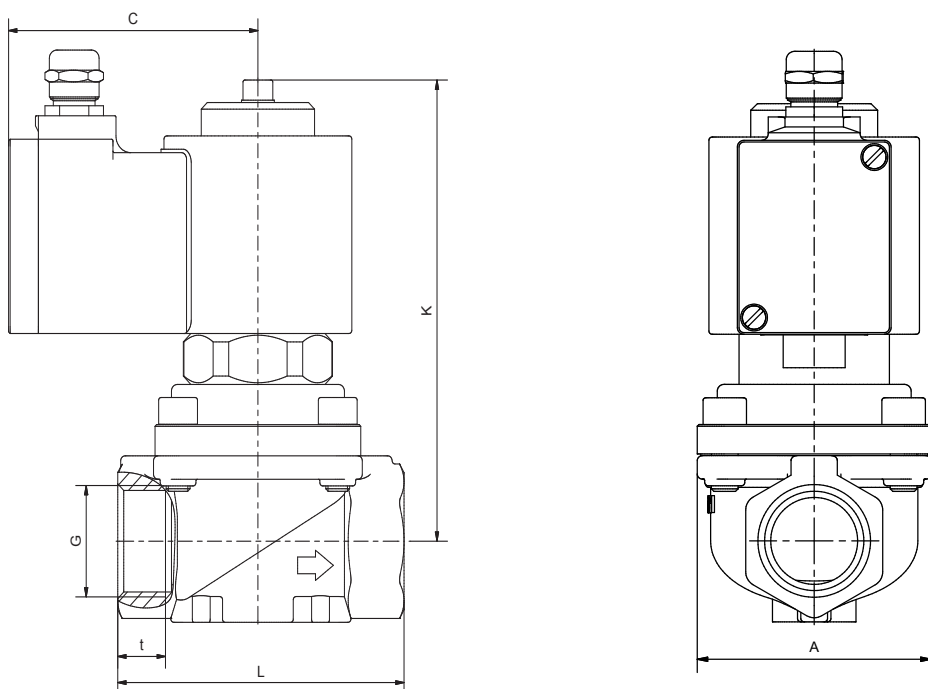

Type 91K

Coil	W802			W322				
Type	K9121	K9122	K9123	K9124	K9125	K9126	K9127	K9128
G	1/4	3/8	1/2	3/4	1	1 1/4	1 1/2	2
A	48	48	48	70	70	96	96	112
C	70	70	70	77	77	77	77	77
K	104	104	104	138	138	148	148	183
L	67	67	67	96	96	140	140	168
t	12	12	12	16	16	22	22	22
kg	1,3	1,3	1,2	3,0	3,0	5,0	4,5	6,5

Coil	.242			.272
Type	K9126	K9127	K9128	K9128
G	1 1/4	1 1/2	2	2
A	96	96	112	112
C	93	93	93	107
K	189	188	194	240
L	140	140	168	168
t	22	22	22	22
kg	6,5	6,5	7,5	12,0



DIMENSIONS

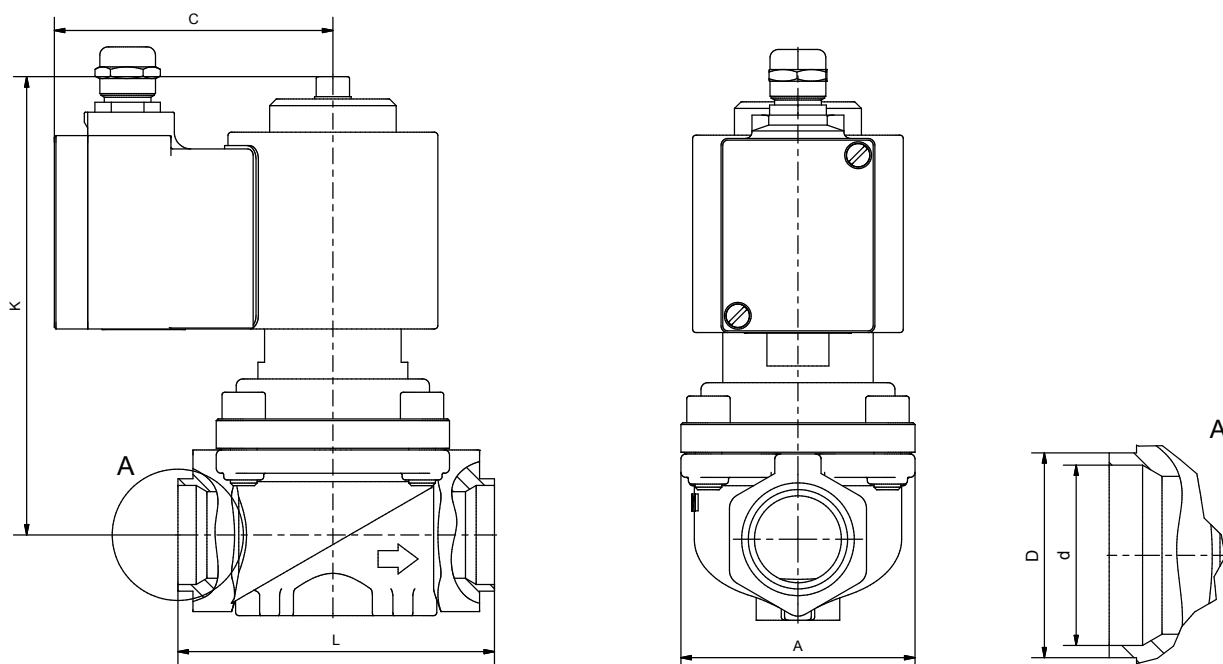

Type 91K

Coil	W802			W322			.242			.272
Type	K9123	K9124	K9125	K9126	K9127	K9128	K9126	K9127	K9128	K9128
G	1/2	3/4	1	1 1/4	1 1/2	2	1 1/4	1 1/2	2	2
A	48	70	70	96	96	112	96	96	112	112
C	70	77	77	77	77	77	93	93	93	107
K	104	138	138	148	148	183	189	188	194	240
L	67	96	96	140	140	168	140	140	168	168
D	21,3	26,9	33,7	42,4	48,3	60,3	42,4	48,3	60,3	60,3
d	18,1	23,7	29,7	38,4	44,3	55,1	38,4	44,3	55,1	55,1
kg	1,2	3,0	3,0	5,0	4,5	6,5	6,5	6,5	7,5	12,0



INFORMATION

- It is imperative to observe the installation and safety instructions in our operating and service manuals.
- For information on our GSR ordering code, please refer to our catalogs. If you have any questions, we will be glad to assist you.
- Required ordering information: valve type, function NC/NO, pressure range, connection, nominal width, medium, flow rate, medium and ambient temperatures, connection voltage.
- **Detailed production-specific drawings and other technical information will be made available when an order is placed.**

PLEASE NOTE

Each individual application decides which valve type is required, the main factor being the resistance of the materials to the operating medium. The correct selection of materials requires knowledge of the concentration, temperature and degree of contamination of the medium. Other criteria include the operating pressure and max. volumetric flow, since, in addition to high temperatures, high pressures and high flow rates must also be taken into account when selecting the materials.

All materials used for our valves, be it housing, seals or magnets, will be carefully selected in view of the different application areas. Any information given is non-binding and serves for orientation only. No claims under warranty can be derived therefrom.

Heating and power of solenoid coils

The GSR default solenoid valves are designed for continuous operation (100% ED = power-on time) under normal operating conditions.

The pulling force of a solenoid coil is basically influenced by three elements:

- The self-heating of the magnetic coil
- The medium temperature
- The ambient temperature

GSR solenoid coils are by default designed for a maximum ambient temperature of +40 °C. This specification applies for the maximum allowable operating pressure specified in the data sheet of the corresponding valve and a medium temperature of +80 °C.

A higher ambient temperature is possible, when lower values are applied for the other influencing parameters. When the max. operation pressure and max. ambient temperature of +50 °C is given the medium temperature is not allowed to be higher than max. +50 °C. In addition to that, deviations from the default design temperature range are possible, e.g. when temperature coils or other constructive measures are used. Please contact the GSR headquarters to discuss the specific application.

More precise specifications and technical data with regard to the operating conditions can be found in the data sheets of the solenoid coils and the solenoid valve regarded. Please observe that the surface temperature of a permanently loaded coil can amount up to +120 °C, solely by the self-heating of the coil. The power consumption of our default solenoid valves was calculated to DIN VDE 05820 for a coil temperature of +20 °C.

- The GSR logo is a registered trademark of GSR Ventiltechnik GmbH & Co. KG.
- Note: All texts and images are the property of GSR Ventiltechnik GmbH & Co. KG and must not be replicated or modified, not even in part, without written approval.
- Original products may differ from the product images shown, due to different materials and the like.
- Subject to error and changes.

State: 02/2016, MK-MG, Version 1.

