



PRODUCT INFORMATION

**Serving the Gas Industry
Worldwide**

FILTERS

2

Introduction

- The Series 121 filter is an inline design with straight through filtration and the Series 122 is an angle type filter.
- Use with confidence on natural and manufactured gases of non-aggressive nature, including Nitrogen, Carbon Dioxide, Propane and Butane.

Application

- Designed to remove grit, dirt and pipe scale from the gas stream, and to provide the protection necessary for the efficient operation of gas pressure regulators, meters and control valves.

Features

- Quick Release Cover.
- Reduced outlet size connecting branches.
- Stainless steel element with choice of filtration, 50 or 200 micron.
- Top withdrawal of filter element.
- Differential pressure gauge/purge bosses.
- Locking facility.

Optional Features

- Viton Seals.
- Differential Pressure Gauge.

SERVICE CONDITIONS	
Working Pressure	Up to 10.5 barg
Pressure range/filtration in accordance with V9	2 bar g - 200 Micron 7 bar g - 50 Micron
Maximum element differential pressure	1.25 bar g
Temperature Range	-20°C to +60°C

MATERIALS OF CONSTRUCTION	
SERIES 121 & 122 FILTER	
Body, Cover and Bridge	Ductile Iron to BS EN 1563 Grade: EN-GJS-400-18
Bridge pin, Spindle	Stainless Steel: BS.970 420 S29 AISI/SAE 420
'O' Ring	Nitrile Rubber: BGC/PS/LC6
Elements	Stainless Steel: BS.970 304 S15 AISI/SAE 304

SIZE RANGE						
SERIES 121 - INLINE			SERIES 122 - ANGLE TYPE			
Inlet	Outlet Branch		Inlet	Outlet Branch		
80	50	80	80	50	80	
100	50	100	100	50	80	100
150	80	150	150	80	150	
200	100	200	200	100	200	
250	250		250	250		
300	300		300	300		

All Dimensions in mm
 Flanges to PN16:BS EN 1092.2:1997
 (ASA Class 150 available on request).



FILTERS

Dimensions & Weights

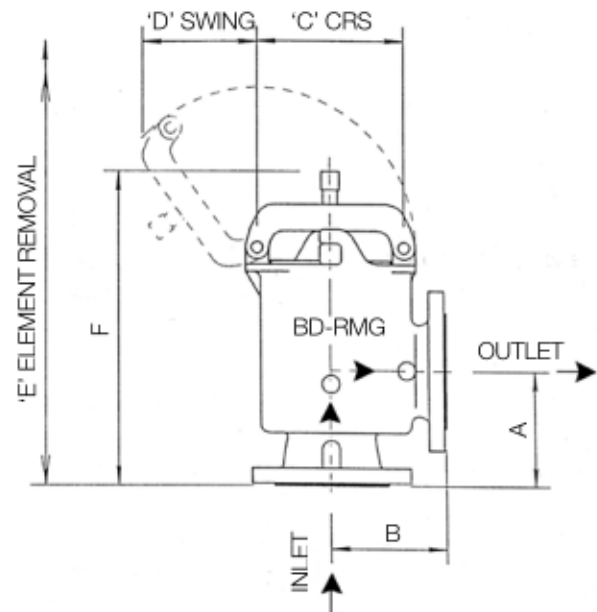
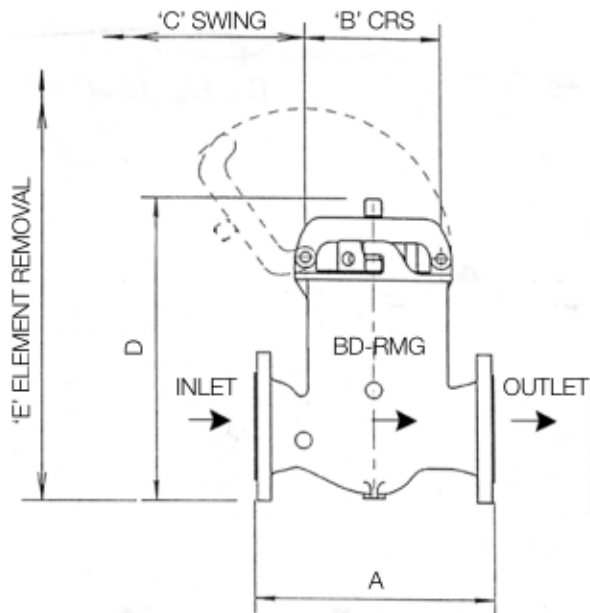

SERIES 121 - INLINE FILTER											
Inlet DN	80		100			150		200		250	300
Outlet DN	50	80	50	80	100	80	150	100	200	250	300
A	392	304	433	356	576	483	654	559	660	660	
B	188		203		300		336		400	400	
C	150		160		225		220		250	245	
D	484		455		610		647		813	995	
E	597		587		767		910		1090	1425	
Wt (Kgs)	37	36	41	42	54	56	100	111	172	250	

All dimensions in mm

SERIES 122 - ANGLE TYPE FILTER											
Inlet DN	80		100			150		200		250	300
Outlet DN	50	80	50	80	100	80	150	100	200	250	300
A	152		159		235		311		387	463	
B	240	152	255	255	159	335	235	390	311	387	463
C	188		203		300		336		400	400	
D	150		160		225		220		250	245	
E	574		549		747		845		1065	1270	
F	494		460		578		637		814	840	
Wt (Kgs)	35	34	39	41	40	52	54	98	109	170	248

All dimensions in mm

FILTERS

Series 121: Pressure Drop

DN 80 x DN 80 50 or 200 MICRON								
P1 MBAR	25	150	200	350	1000	2500	4000	7000
Flow: SM ³ /Hr								
100	1.6	1.4	1.4	1.2	0.8	0.5	0.3	0.2
200	6.4	5.7	5.5	4.9	3.3	1.9	1.3	0.8
300	14.5	12.9	12.4	11.0	7.5	4.3	3.0	1.9
400	25.8	23.0	22.0	19.6	13.3	7.6	5.3	3.3
500	40.3	35.9	34.4	30.7	20.8	11.9	8.3	5.2
600	58.0	51.7	49.6	44.1	29.9	17.1	12.0	7.5
700	—	70.4	67.5	60.1	40.7	23.3	16.3	10.2
800	—	—	88.2	78.5	53.1	30.5	21.3	13.3
900	—	—	—	99.3	67.3	38.5	27.0	16.9
1000	—	—	—	—	83.0	47.6	33.3	20.9
1500	—	—	—	—	—	107.1	75.0	46.9
2000	—	—	—	—	—	—	133.4	83.4
2500	—	—	—	—	—	—	208.4	130.4
3000	—	—	—	—	—	—	—	187.7

DN 200 x DN 200 50 or 200 MICRON								
P1 MBAR	25	150	200	350	1000	2500	4000	7000
Flow: SM ³ /Hr								
400	0.7	0.6	0.6	0.5	0.3	0.2	0.1	0.1
600	1.5	1.3	1.3	1.1	0.8	0.4	0.3	0.2
800	2.6	2.4	2.3	2.0	1.4	0.8	0.5	0.3
1000	4.1	3.7	3.5	3.1	2.1	1.2	0.9	0.5
2000	16.5	14.7	14.1	12.6	8.5	4.9	3.4	2.1
4000	66.0	58.9	56.4	50.2	34.0	15.9	13.7	8.5
6000	—	132.4	127.0	113.0	76.5	43.8	30.7	19.2
8000	—	—	225.8	200.9	136.0	78.0	54.6	34.2
10000	—	—	—	313.9	212.6	121.8	85.4	53.4
12000	—	—	—	—	306.1	175.4	122.9	76.9
14000	—	—	—	—	—	238.7	167.3	104.7
16000	—	—	—	—	—	—	218.5	136.7
18000	—	—	—	—	—	—	276.6	173.0
20000	—	—	—	—	—	—	—	213.6

DN 100 x DN 100 50 or 200 MICRON								
P1 MBAR	25	150	200	350	1000	2500	4000	7000
Flow: SM ³ /Hr								
100	0.6	0.5	0.5	0.5	0.3	0.2	0.1	0.1
200	2.4	2.1	2.1	1.8	1.2	0.7	0.5	0.3
400	9.6	8.6	8.2	7.3	5.0	2.8	2.0	1.2
600	21.7	19.3	18.5	16.5	11.2	6.4	4.5	2.8
800	38.5	34.4	32.9	29.3	19.8	11.4	8.0	5.0
1000	60.1	53.7	51.5	45.8	31.0	17.8	12.5	7.8
1500	—	120.8	115.8	103.1	69.8	40.0	28.0	17.5
2000	—	—	205.9	183.2	124.0	71.1	49.8	31.2
2500	—	—	—	286.3	193.8	111.1	77.8	48.7
3000	—	—	—	—	279.1	159.9	112.1	70.1
3500	—	—	—	—	—	217.7	152.6	95.4
4000	—	—	—	—	—	—	199.3	124.7
4500	—	—	—	—	—	—	252.2	157.8
5000	—	—	—	—	—	—	—	194.8

DN 250 x DN 250 50 or 200 MICRON								
P1 MBAR	25	150	200	350	1000	2500	4000	7000
Flow: SM ³ /Hr								
500	0.4	0.4	0.4	0.3	0.2	0.1	0.1	0.1
1000	1.7	1.5	1.4	1.3	0.9	0.5	0.3	0.2
1500	3.8	3.4	3.3	2.9	2.0	1.1	0.8	0.5
2000	6.8	6.0	5.8	5.1	3.5	2.0	1.4	0.9
3000	15.2	13.6	13.0	11.6	7.8	4.5	3.1	2.0
4000	27.0	24.1	23.1	20.6	13.9	8.0	5.6	3.5
6000	—	54.3	52.0	46.3	31.2	18.0	12.6	7.9
8000	—	—	92.5	82.3	55.7	31.9	22.4	14.0
10000	—	—	—	128.6	87.1	49.9	35.0	21.9
12000	—	—	—	—	125.4	71.8	50.3	31.5
15000	—	—	—	—	—	112.3	78.7	49.2
20000	—	—	—	—	—	—	139.8	87.5
25000	—	—	—	—	—	—	218.5	136.7
30000	—	—	—	—	—	—	—	196.8

DN 100 x DN 50 50 or 200 MICRON								
P1 MBAR	25	150	200	350	1000	2500	4000	7000
Flow: SM ³ /Hr								
100	1.6	1.4	1.4	1.2	0.8	0.5	0.3	0.2
200	6.4	5.7	5.5	4.9	3.3	1.9	1.3	0.8
300	14.4	12.8	12.3	10.9	7.4	4.2	3.0	1.9
400	—	—	21.9	19.4	13.2	7.5	5.3	3.3
500	—	—	—	—	20.6	11.8	8.3	5.2
600	—	—	—	—	29.6	17.0	11.9	7.4
700	—	—	—	—	—	23.1	16.2	10.1
800	—	—	—	—	—	30.2	21.1	13.2
900	—	—	—	—	—	38.2	26.8	16.7
1000	—	—	—	—	—	47.2	33.0	20.7
1500	—	—	—	—	—	—	74.4	46.5
2000	—	—	—	—	—	—	—	82.7
2500	—	—	—	—	—	—	—	129.2

DN 300 x DN 300 50 or 200 MICRON								
P1 MBAR	25	150	200	350	1000	2500	4000	7000
Flow: SM ³ /Hr								
1000	0.9	0.8	0.8	0.7	0.5	0.3	0.2	0.1
2000	3.6	3.2	3.1	2.7	1.8	0.7	0.7	0.5
3000	8.1	7.2	6.9	6.1	4.2	2.4	1.7	1.0
4000	14.3	12.8	12.3	10.9	7.4	4.2	3.0	1.9
5000	22.4	20.0	19.2	17.0	11.5	6.6	4.6	2.9
6000	32.2	28.8	27.6	24.5	16.6	9.5	6.7	4.2
8000	—	51.1	49.0	43.6	29.5	16.9	11.9	7.4
10000	—	—	76.6	68.2	46.2	26.4	18.5	11.6
15000	—	—	—	153.4	103.9	59.5	41.7	26.1
20000	—	—	—	—	184.6	105.8	74.1	46.4
25000	—	—	—	—	—	165.3	115.8	72.5
30000	—	—	—	—	—	—	166.8	104.4
35000	—	—	—	—	—	—	227.1	142.0
40000	—	—	—	—	—	—	—	185.5

PRESSURE DROP IN MBARG SG: 0.6

DN 150 x DN 150 50 or 200 MICRON								
P1 MBAR	25	150	200	350	1000	2500	4000	7000
Flow: SM ³ /Hr								
200	0.5	0.5	0.4	0.4	0.3	0.2	0.1	0.1
400	2.1	1.9	1.8	1.6	1.1	0.6	0.4	0.3
600	4.7	4.2	4.0	3.6	2.4	1.4	1.0	0.6
800	8.3	7.4	7.1	6.3	4.3	2.5	1.7	1.1
1000	13.0	11.6	11.1	9.9	6.7	3.8	2.7	1.7
2000	52.1	46.5	44.6	39.7	26.9	15.4	10.8	6.8
3000	—	104.7	100.3	89.3	60.5	34.6	24.3	15.2
4000	—	—	178.4	158.7	107.5	61.6	43.2	27.0
5000	—	—	—	248.0	167.9	96.2	67.4	42.2
6000	—	—	—	—	241.8	138.6	97.1	60.8
7000	—	—	—	—	—	188.6	132.2	82.7
8000	—	—	—	—	—	—	172.6	108.0
9000	—	—	—	—	—	—	218.5	136.7
10000	—	—	—	—	—	—	—	168.8

REDUCED OUTLET SIZES

For reduced outlet size filters the pressure drop is approximately the same as a standard filter size equal to that of the outlet connection.

i.e.

PD 80	x	50	=	PD 100	x	50
PD 150	x	80	=	PD 80	x	80
PD 200	x	100	=	PD 100	x	100

FILTERS

Series 122: Pressure Drop

DN 80 x DN 80 50 or 200 MICRON								
P1 MBAR	25	150	200	350	1000	2500	4000	7000
Flow: SM ³ /Hr								
100	0.2	0.2	0.2	0.2	0.1	0.1	0.1	0.0
200	0.9	0.8	0.8	0.7	0.5	0.3	0.2	0.1
300	2.0	1.8	1.7	1.6	1.1	0.6	0.4	0.3
400	3.6	3.2	3.1	2.8	1.9	1.1	0.7	0.5
500	5.7	5.1	4.8	4.3	2.9	1.7	1.2	0.7
600	8.1	7.3	7.0	6.2	4.2	2.4	1.7	1.1
700	—	9.9	9.5	8.4	5.7	3.3	2.3	1.4
800	—	—	12.4	11.0	7.5	4.3	3.0	1.9
900	—	—	—	14.0	9.5	5.4	3.8	2.4
1000	—	—	—	—	11.7	6.7	4.7	2.9
1500	—	—	—	—	—	15.0	10.5	6.6
2000	—	—	—	—	—	—	18.7	11.7
2500	—	—	—	—	—	—	29.3	18.3
3000	—	—	—	—	—	—	—	26.4

DN 100 x DN 100 50 or 200 MICRON								
P1 MBAR	25	150	200	350	1000	2500	4000	7000
Flow: SM ³ /Hr								
100	0.1	0.1	0.1	0.1	0.0	0.0	0.0	0.0
200	0.4	0.3	0.3	0.3	0.2	0.1	0.1	0.0
400	1.5	1.3	1.3	1.1	0.8	0.4	0.3	0.2
600	3.3	3.0	2.8	2.5	1.7	1.0	0.7	0.4
800	5.9	5.3	5.0	4.5	3.0	1.7	1.2	0.8
1000	9.2	8.2	7.9	7.0	4.8	2.7	1.9	1.2
1500	—	18.5	17.7	15.8	10.7	6.1	4.3	2.7
2000	—	—	31.5	28.1	19.0	10.9	7.6	4.8
2500	—	—	—	43.8	29.7	17.0	11.9	7.5
3000	—	—	—	—	42.8	24.5	17.2	10.7
3500	—	—	—	—	—	33.3	23.4	14.6
4000	—	—	—	—	—	—	30.5	19.1
4500	—	—	—	—	—	—	38.6	24.2
5000	—	—	—	—	—	—	—	29.8

DN 100 x DN 50 50 or 200 MICRON								
P1 MBAR	25	150	200	350	1000	2500	4000	7000
Flow: SM ³ /Hr								
100	1.0	0.9	0.9	0.8	0.5	0.3	0.2	0.1
200	4.2	3.7	3.6	3.2	2.2	1.2	0.9	0.5
300	9.4	8.4	8.0	7.2	4.8	2.8	1.9	1.2
400	—	—	14.3	12.7	8.6	4.9	3.5	2.2
500	—	—	—	—	13.5	7.7	5.4	3.4
600	—	—	—	—	19.4	11.1	7.8	4.9
700	—	—	—	—	—	15.1	10.6	6.6
800	—	—	—	—	—	19.7	13.8	8.7
900	—	—	—	—	—	25.0	17.5	11.0
1000	—	—	—	—	—	30.8	21.6	13.5
1500	—	—	—	—	—	—	48.6	30.4
2000	—	—	—	—	—	—	—	54.1
2500	—	—	—	—	—	—	—	84.5

DN 150 x DN 150 50 or 200 MICRON								
P1 MBAR	25	150	200	350	1000	2500	4000	7000
Flow: SM ³ /Hr								
200	0.1	0.1	0.1	0.1	0.1	0.0	0.0	0.0
400	0.5	0.4	0.4	0.4	0.3	0.1	0.1	0.1
600	1.1	1.0	0.9	0.8	0.6	0.3	0.2	0.1
800	2.0	1.8	1.7	1.5	1.0	0.6	0.4	0.3
1000	3.1	2.7	2.6	2.3	1.6	0.9	0.6	0.4
2000	12.3	11.0	10.5	9.4	6.3	3.6	2.5	1.6
3000	—	24.7	23.6	21.0	14.2	8.2	5.7	3.6
4000	—	—	42.0	37.4	25.3	14.5	10.2	6.4
5000	—	—	—	58.4	39.6	22.7	15.9	9.9
6000	—	—	—	—	57.0	32.7	22.9	14.3
7000	—	—	—	—	—	44.4	31.1	19.5
8000	—	—	—	—	—	—	40.7	25.5
9000	—	—	—	—	—	—	51.5	32.2
10000	—	—	—	—	—	—	—	39.8

DN 200 x DN 200 50 or 200 MICRON								
P1 MBAR	25	150	200	350	1000	2500	4000	7000
Flow: SM ³ /Hr								
400	0.2	0.1	0.1	0.1	0.1	0.0	0.0	0.0
600	0.3	0.3	0.3	0.3	0.2	0.1	0.1	0.0
800	0.6	0.6	0.5	0.5	0.3	0.2	0.1	0.1
1000	1.0	0.9	0.8	0.7	0.5	0.3	0.2	0.1
2000	3.9	3.5	3.3	3.0	2.0	1.1	0.8	0.5
4000	15.5	13.9	13.3	11.8	8.0	4.6	3.2	2.0
6000	—	31.2	29.9	26.6	18.0	10.3	7.2	4.5
8000	—	—	53.2	47.3	32.1	18.4	12.9	8.1
10000	—	—	—	74.0	50.1	28.7	20.1	12.6
12000	—	—	—	—	72.1	41.3	29.0	18.1
14000	—	—	—	—	—	56.3	39.4	24.7
16000	—	—	—	—	—	—	51.5	32.2
18000	—	—	—	—	—	—	65.2	40.8
20000	—	—	—	—	—	—	—	50.3

DN 250 x DN 250 50 or 200 MICRON								
P1 MBAR	25	150	200	350	1000	2500	4000	7000
Flow: SM ³ /Hr								
500	0.1	0.1	0.1	0.1	0.1	0.0	0.0	0.0
1000	0.4	0.4	0.3	0.3	0.2	0.1	0.1	0.1
1500	0.9	0.8	0.8	0.7	0.5	0.3	0.2	0.1
2000	1.6	1.4	1.4	1.2	0.8	0.5	0.3	0.2
3000	3.6	3.2	3.1	2.7	1.8	1.1	0.7	0.5
4000	6.4	5.7	5.4	4.8	3.3	1.9	1.3	0.8
6000	—	12.8	12.3	10.9	7.4	4.2	3.0	1.9
8000	—	—	21.8	19.4	13.1	7.2	5.3	3.3
10000	—	—	—	30.3	20.5	11.8	8.2	5.2
12000	—	—	—	—	29.5	16.9	11.9	7.4
15000	—	—	—	—	—	26.4	18.5	11.6
20000	—	—	—	—	—	—	33.0	20.6
25000	—	—	—	—	—	—	51.5	32.2
30000	—	—	—	—	—	—	—	46.4

DN 300 x DN 300 50 or 200 MICRON								
P1 MBAR	25	150	200	350	1000	2500	4000	7000
Flow: SM ³ /Hr								
1000	0.3	0.3	0.3	0.2	0.2	0.1	0.1	0.0
2000	1.3	1.2	1.1	1.0	0.7	0.4	0.3	0.2
3000	2.9	2.6	2.5	1.1	1.5	0.9	0.6	0.4
4000	5.2	4.6	4.5	4.0	2.7	1.5	1.1	0.7
5000	8.1	7.3	7.0	6.2	4.2	2.4	1.7	1.1
6000	11.7	10.4	10.0	8.9	6.0	3.5	2.4	1.5
8000	—	18.6	17.8	15.8	10.7	6.1	4.3	2.7
10000	—	—	27.8	24.8	16.8	9.6	6.7	4.2
15000	—	—	—	55.7	37.7	21.6	15.1	9.5
20000	—	—	—	—	67.1	38.4	26.9	16.8
25000	—	—	—	—	—	60.0	42.1	26.3
30000	—	—	—	—	—	—	60.6	37.9
35000	—	—	—	—	—	—	82.5	51.6
40000	—	—	—	—	—	—	—	67.4

PRESSURE DROP IN MBARG SG: 0.6

REDUCED OUTLET SIZES

For reduced outlet size filters the pressure drop is approximately the same as a standard filter size equal to that of the outlet connection.

i.e.

PD 80 x 50 = PD 100 x 50
 PD 100 x 80 = PD 80 x 80
 PD 150 x 80 = PD 80 x 80
 PD 200 x 100 = PD 100 x 100

Application

- The Series 124 is an angle type filter designed to ensure a clean and positive supply of natural gas, air and other non-aggressive gases.

Features

- Large surface area of filtration.
- Quick release plug (crossbore drilled vent).
- Pressure differential tapplings available on sizes 1" and above.
- Stainless steel element, choice of 50 or 200 micron filtration.
- Dust catching facility.

SERVICE CONDITIONS	
Maximum Working Pressure (dependant upon material)	Brass: Up to 25 bar g Ductile Iron: Up to 19 bar g
Temperature Range	-20°C to + 60°C

Connections

Sizes: Rc3/4 - Rc2 Screwed (BS.21)
 DN 50 - Flanged to PN16: BS EN 1092-2:1997
 (Optional ANSI 150 on request.)

SIZE RANGE		
Size	Material	Connection
3/4"	Brass	F
1"	Brass	F
1.1/2"	Brass	F
2"	Ductile Iron	F
DN50	Ductile Iron	FL

Key: F - Female thread, FL - flanged.

MATERIALS OF CONSTRUCTION	
Body	Brass: BS.1400 DCB/3 Ductile Iron to BS1563 Grade: EN-GJS-400-18
Element	Stainless Steel: (50/200 micron) BS.970 302S25
'O' Ring	Nitrile Rubber: BGC/PS/LC6



7

FILTERS

Dimensions & Weights (Series 124)

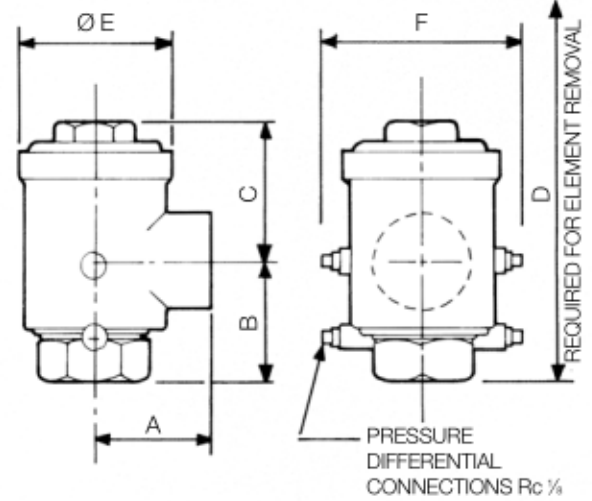
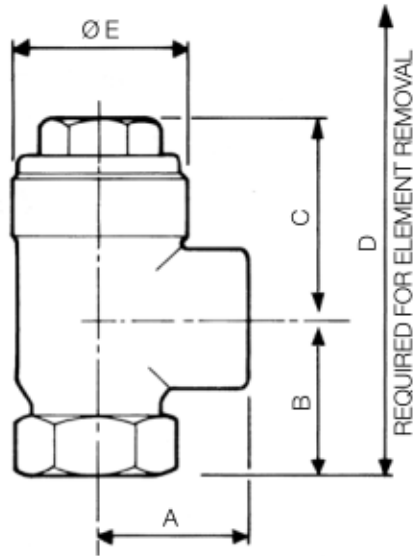

SCREWED FEMALE						
Size	A	B	C	D	E	Weight
3/4"	38	41	54	135	42	0.6Kg
1"	50	53	65	178	54	1.2Kg

SCREWED FEMALE							
Size	A	B	C	D	E	F	Weight
1 1/2"	78	78	93	265	80	110	1.6Kg
2"	88	95	110	360	116	150	7.4Kg

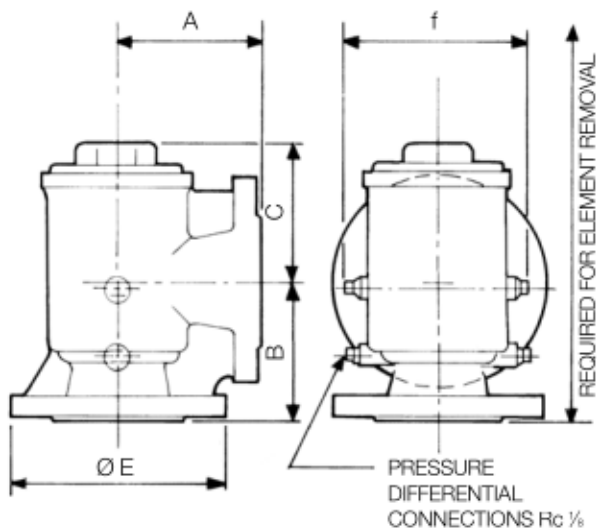

FLANGED							
Size	A	B	C	D	E	F	Weight
DN 50	110	110	110	345	165	150	13.7Kg

All dimensions in mm

Application

- The Series 126 is an inline type filter designed to ensure a clean and positive supply of natural gas, air and other non-aggressive gases.

Features

- Quick release plug (crossbore drilled vent).
- Pressure differential tapplings available on 1" and above.
- Stainless steel element, choice of 50 or 200 micron filtration.

SERVICE CONDITIONS	
Maximum Working Pressure (dependant upon material)	Brass: Up to 25 bar g Ductile Iron: Up to 19 bar g
Temperature Range	-20°C to + 60°C

Connections

Sizes: Rc1/2 - Rc1.1/2 Screwed (BS.21)
 DN 50 - Flanged to PN16: BS EN 1092-2:1997
 (Optional ANSI 150 on request.)

SIZE RANGE		
Size	Material	Connection
1/2"	Brass	F
3/4"	Brass	F
1"	Brass	F
1 1/2"	Brass	F
DN 50	Ductile Iron	FL

Key: F - Female thread, FL - flanged.

MATERIALS OF CONSTRUCTION	
Body	Brass: BS.1400 DCB/3 Ductile Iron to Grade: EN-GJS-400-18
Element	Stainless Steel: (50/200 micron) BS.970 302S25
'O' Ring	Nitrile Rubber: BGC/PS/LC6



FILTERS

Dimensions & Weights (Series 126)

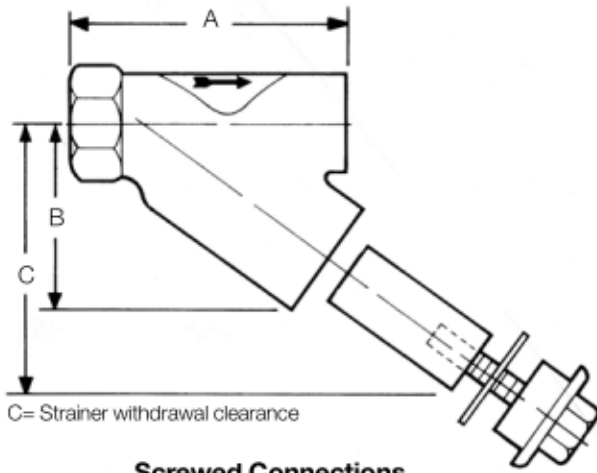

SCREWED CONNECTIONS				
Size	½in	¾in	1 in	1½in
	mm	mm	mm	mm
A	79	89	110	152
B	50	64	76	114
C	76	90	127	165

WEIGHTS				
MAT'L	½in	¾in	1 in	1½in
	kg	kg	kg	kg
Brass	0.5	1.0	1.0	2

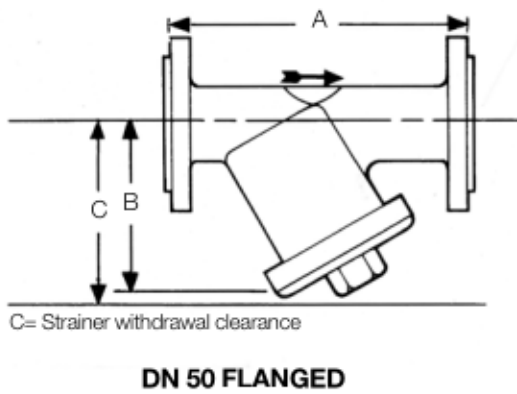

FLANGED CONNECTION			
Size DN 50			
A	B	C	Weight Kg's
mm	mm	mm	kg
230	130	180	10.5

All dimensions in mm