

# RPM Rotary Gas Meters



# RPM Rotary Gas Meters

Elster American Meter's RPM rotary meters are a positive displacement meter used to measure natural gas and other various non-corrosive industrial gases (air, nitrogen, carbon dioxide) over a wide range of flow rates and operating pressures.

## Features and Advantages

- ANSI B 109.3 compliant
- 7 meter sizes ranging from 1500 - 16,000 CFH, connections from 2"-4"
- Heavy duty design of the body resists bending to prevent "lock ups"
- High rangeability from low flow to high flows insures accuracy
- Low pressure drop across meter even at high flows
- Reverse flow capability standard on all models
- Flanged to meet ANSI 125/150 specifications
- Differential pressure taps on inlet and outlet flanges
- Non-lubricating indexes reduce maintenance
- Vented index cover reduces condensation
- High impact resistant, UV stabilized index covers
- Anodized extruded aluminum body and impellers
- Splash lubrication for main bearings
- AMR/AMI Compatible



## RPM Rotary Gas Meters

Elster American Meter's RPM series rotary meters provide accurate measurement and outstanding long-term performance for critical custody transfer applications. The positive displacement rotary design has a proven track record of long-term accuracy and reliability, thus, earning its position as a leading metering technology in the natural gas utility industry worldwide.

The unparalleled performance of the RPM meter is further enhanced by its versatility. All models are available with a variety of instrumentation accessories commonly used in utility and industrial applications for interfacing with data acquisition and meter reading systems. All models have the highest pressure rating of any standard line of rotary meters on the market allowing the RPM application flexibility. All meters can easily be configured for reverse flow installations which can reduce installation costs and mitigate unsightly and undesirable piping configurations.

With over 170 years of metering history and innovation, Elster American Meter RPM meters provide measurement experts the security of knowing their measurement is uncompromised. When it comes to accuracy, reliability, and versatility, choose the most trusted name in measurement – Elster American Meter.



# RPM Rotary Gas Meter Models

Standard models and optional accessories provide versatility and flexibility to fit the most demanding applications.



RPM Series Rotary Meters meet the following:

- ASME Boiler & Pressure Vessel Code; Section VIII
- ANSI B16.5 Flanged Pipe & Fittings
- ANSI B31.8 Gas Piping
- ANSI B109.3 Rotary Gas Meters (2000)
- 49 CFR 192 Min. Federal Safety Standards
- National Safe Transit Association (NSTA-1A-Packaging)
- Measurement Canada approval AG-0420 REV 4

## Standard Models

CTR - Uncorrected Mechanical Totalizer

CID - CTR with Instrument Drive

CRVP - CTR with Remote Volume Pulser (RVP)

CMTC - Continuous Mechanical Temperature Compensator

TCID - CMTC with Instrument Drive

TRVP - CMTC with Remote Volume Pulser (RVP)



## Optional Accessories

Other options include

- Reverse Flow
- Thermowell
- RVP Mounting Kit
- Instrument Drive Kit
- Pete's Plugs II<sup>®</sup>
- Mounting bolts and flange gaskets
- Gasket Strainers
- Pressure Compensating Indexes
- Restricting Orifice Plate
- Differential Pressure Gauge Kit
- 1-1/2" NPT Mounting Kit for 2" flanged meters
- Proving Clamp
- Factory AMR/AMI Installation

## Available Register Masking & Multipliers

RPM register masking & multipliers are available in both English and Metric units.

English Units (FT<sup>3</sup>)

- 4 x 1000<sup>1,3</sup>
- 5 x 100<sup>1,2,3</sup>
- 5 x 1000<sup>2,3</sup>
- 6 x 10<sup>1</sup>
- 6 x 100<sup>1,2,3</sup>
- 6 x 1000<sup>4</sup>

Metric Units (m<sup>3</sup>)

- 5 x 0.1<sup>1</sup>
- 6 x 0.1<sup>1</sup>
- 6 x 1<sup>1,2,3</sup>
- 6 x 10<sup>2,4</sup>



<sup>1</sup> 1.5M-11M CTR, <sup>2</sup> 16M CTR, <sup>3</sup> 1.5M-11M CMTC, <sup>4</sup> 16M CMTC



# RPM Rotary Gas Meter Operating Principles

The RPM rotary gas meter operates on the positive displacement technology which makes volumetric measurements by displacing finite increments of gas. The positive displacement occurs within a cavity formed between the meter's internal housing and its rotating impellers. The contra-rotating "figure 8" impellers turn as a result of pressure drop across the meter created as downstream gas is consumed. The rotating impellers separate the flowing gas stream into small, finite, volumes and are counted using a mechanical or electronic index.

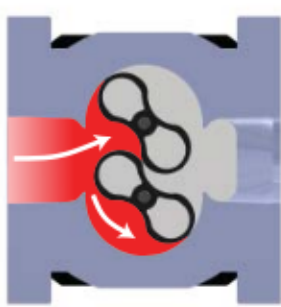

As the bottom impeller rotates toward the horizontal position, gas enters the cavity created between the impeller and the housing.

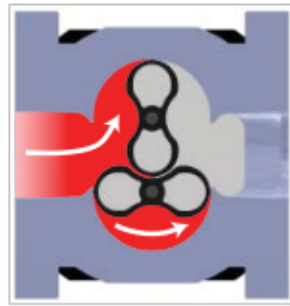

When the bottom impeller reaches the horizontal position, a finite volume of gas is captured in the bottom cavity.

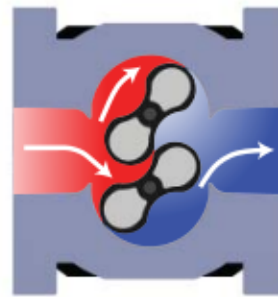

As the impellers continue to turn, the volume of gas in the lower cavity is discharged. Simultaneously, gas is entering the space between the top impeller and housing.

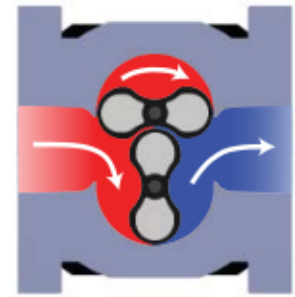

After further rotation the top impeller becomes horizontal and a finite volume of gas is captured in the top cavity.

1 Driven Magnet

2 Drive Magnet

The index register is magnetically-coupled to the RPM meter body and is completely isolated and protected from the gas stream. This feature, when combined with the oil-free design of the index register, provides long-term accurate, uninterrupted and maintenance-free measurement.

3 Drive Gear

4 Oil Slinger

The RPM meter can be configured for reverse flow applications by simply interchanging the position of the drive gear and oil slinger. This feature increases the RPM meter's flexibility to meet varying installation restrictions.

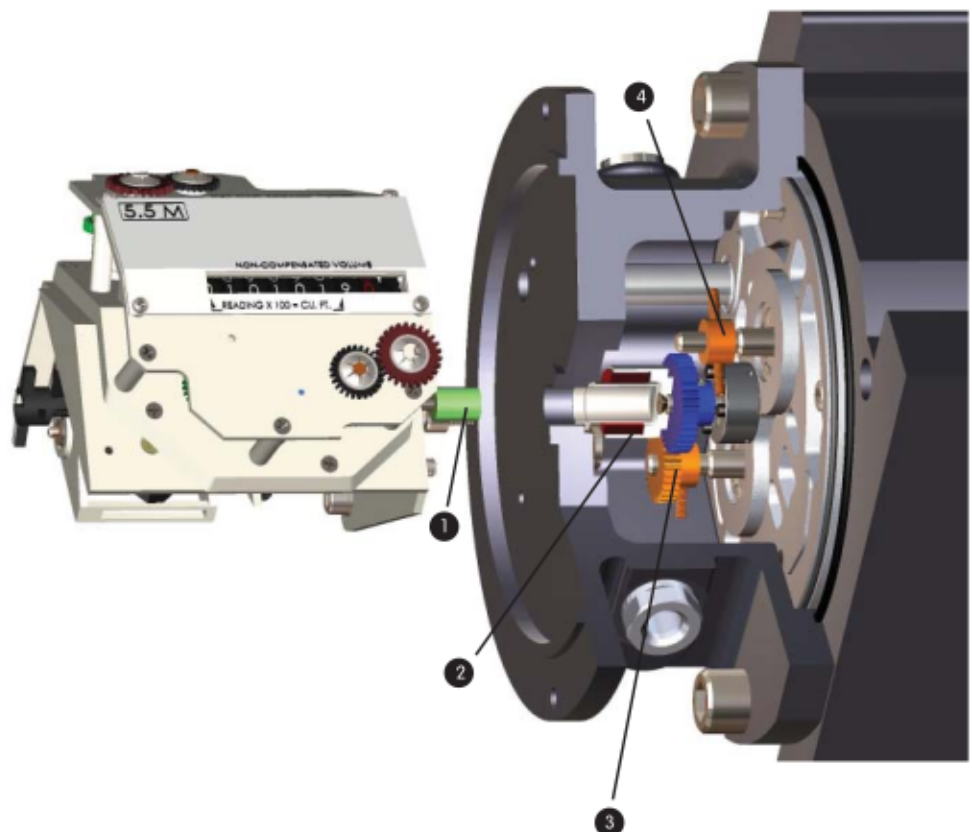

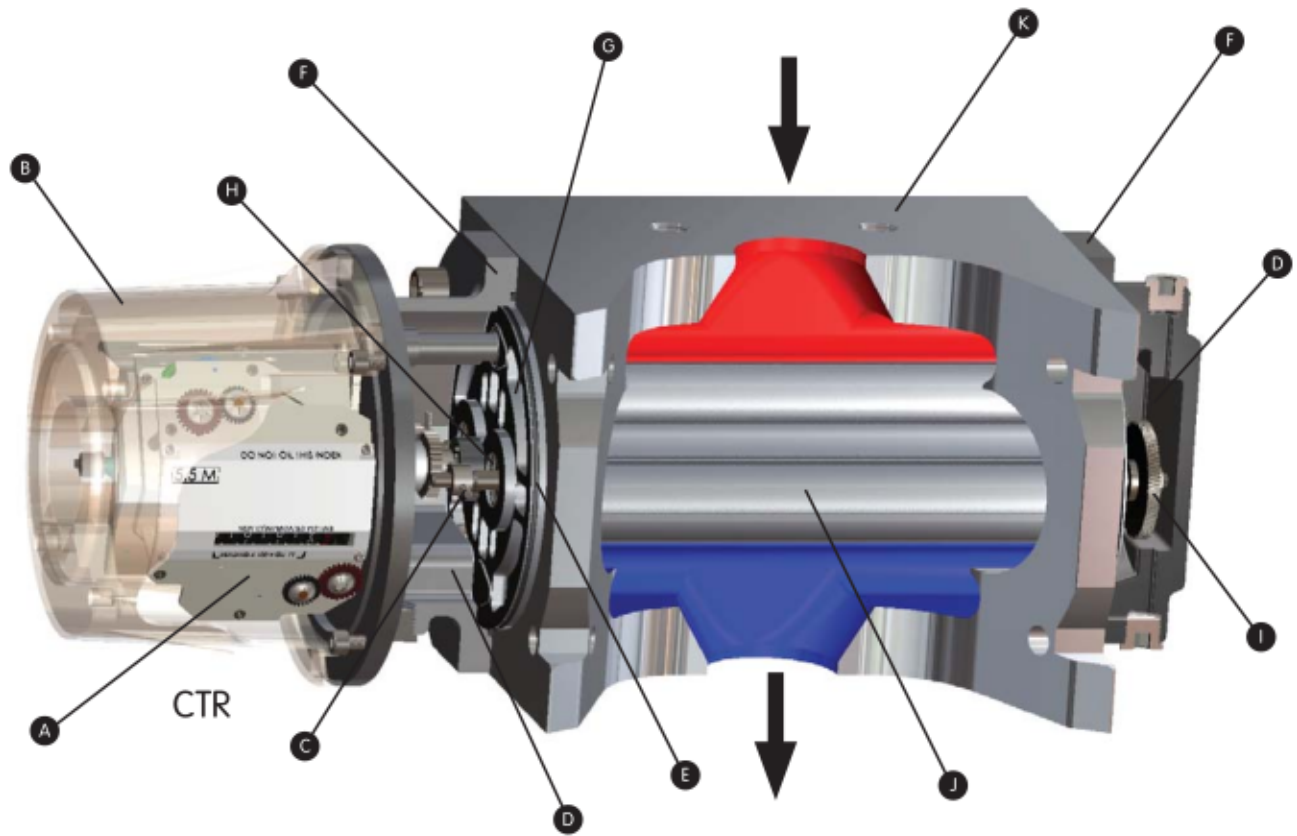

### Material Specifications

- A** Index Register
- B** Index Cover - Lexan
- C** Oil Slinger - Alloy steel
- D** Oil Reservoir - Elster American Meter recommends using Shell Tellus Oils T 15 or Texaco Aircraft Hydraulic #15 lubricating oil
- E** O-Ring Gasket (2)- Buna-N
- F** Case Cover (2) - Aluminum
- G** Bearing Cover (2) - Aluminum, Anodized
- H** Ball Bearing (4) - Radial, double shielded
- I** Timing Gear (2) - SAE 4130 Carbon steel
- J** Impellers - Extruded Aluminum, Hard-Anodized
- K** Case - Extruded Aluminum, Hard-Anodized
- L** Oil filled Bulb and Bellows Transducer
- M** Gas Temperature Indicator
- N** Accuracy Adjustment
- O** Corrected Output Drive
- P** Continuous Mechanical Temperature Compensator (CMTC)
- Q** Corrected Index Reading
- R** Uncorrected Index Reading
- S** Set Gears
- T** Oil Fill
- U** Sight Glass

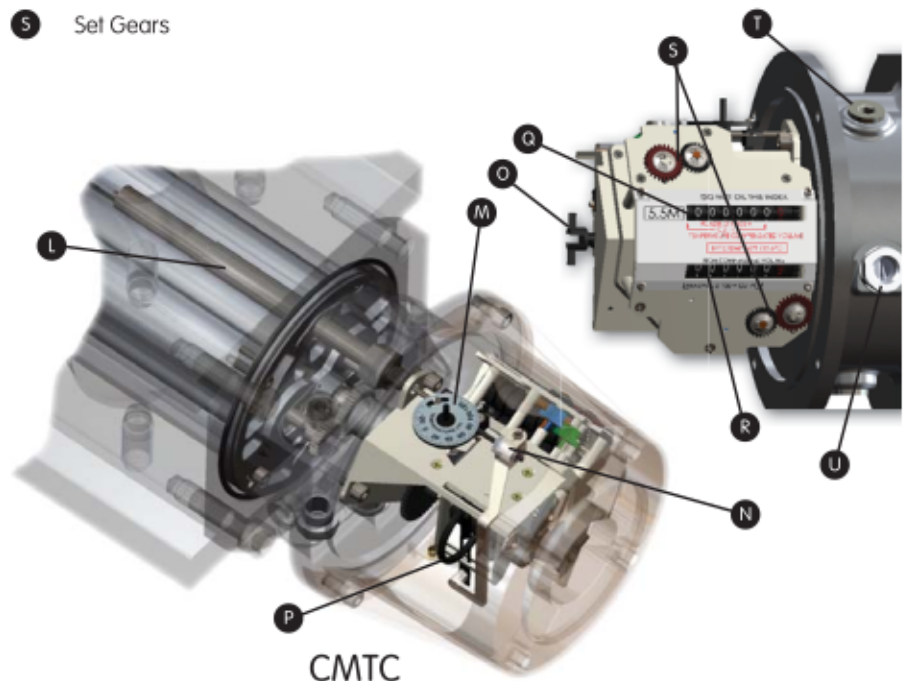

## Technical Data

		Meter Size						
		1.5M	2M	3.5M	5.5M	7M	11M	16M
Description	Units	G25	G40	G65	G100	G130	G200	G250
Rated capacity @ 0.25 PSIG (17 mBarg)	SCFH (Sm <sup>3</sup> /h)	1500 (42.0)	2000 (56.0)	3500 (98.0)	5500 (154.0)	7000 (196.0)	11000 (308.0)	16000 (448.0)
Max. allowable pressure		285 PSIG (1965 kPa)						
Temperature range		- 40 to 140 °F (-40 to 60 °C)						
Rangeability ±1%		>40:1	>43:1	>75:1	>120:1	>70:1	>120:1	>100:1
Rangeability ±2%		>75:1	>80:1	>140:1	>210:1	>115:1	>225:1	>150:1
Start rate	CFH	<3.0	<4.0	<4.0	<4.4	<5.5	<5.5	<7.0
ID/RVP Rate	CF/REV	10	10	10	10	10	10	100
Max. operating speed	RPM	2358	2950	2950	2425	2098	2414	2976
Flange/flange dimension	IN	6.75	6.75	6.75	6.75	9.50	9.50	9.50
Nominal pipe size	IN	2	2	2	2/3	3	4	4

## Dimensions - Inches (mm)

Meter Size	1.5M G25	2M G40	3.5M G65	5.5M (2") G100	5.5M (3") G100	7M G130	11M G200	16M G250
A	17.580 (446.53)	15.580 (395.73)	15.580 (395.73)	19.520 (495.81)	19.520 (495.81)	18.650 (473.71)	20.410 (518.41)	22.822 (579.68)
B	6.390 (162.30)	5.390 (136.90)	5.390 (136.90)	7.360 (186.90)	7.360 (186.90)	6.970 (177.40)	7.980 (202.70)	9.056 (230.02)
C	11.200 (284.48)	10.190 (258.83)	10.190 (258.83)	12.160 (308.86)	12.160 (308.86)	11.420 (290.07)	12.370 (314.20)	13.506 (343.05)
D	6.750 (171.50)	6.750 (171.50)	6.750 (171.50)	6.750 (171.50)	6.750 (171.50)	9.50 (241.30)	9.50 (241.30)	9.50 (241.30)
E	5/8-11 (M16X2)	5/8-11 (M16X2)	5/8-11 (M16X2)	5/8-11 (M16X2)	5/8-11 (M16X2)	5/8-11 (M16X2)	5/8-11 (M16X2)	5/8-11 (M16X2)
F (ANSI)	4.750 (120.65)	4.750 (120.65)	4.750 (120.65)	4.750 (120.65)	6.000 (152.40)	6.000 (152.40)	7.500 (190.50)	7.500 (190.50)
G	6.880 (174.80)	6.880 (174.80)	6.880 (174.80)	6.880 (174.80)	6.880 (174.80)	6.880 (174.80)	6.880 (174.80)	6.880 (174.80)
H	8.000 (203.20)	8.000 (203.20)	8.000 (203.20)	8.000 (203.20)	8.000 (203.20)	8.000 (203.20)	8.000 (203.20)	8.000 (203.20)
I	4.020 (102.11)	4.020 (102.11)	4.020 (102.11)	4.020 (102.11)	4.020 (102.11)	4.020 (102.11)	4.020 (102.11)	4.020 (102.11)
J	4.110 (104.40)	4.110 (104.40)	4.110 (104.40)	4.110 (104.40)	4.110 (104.40)	4.110 (104.40)	4.110 (104.40)	4.110 (104.40)

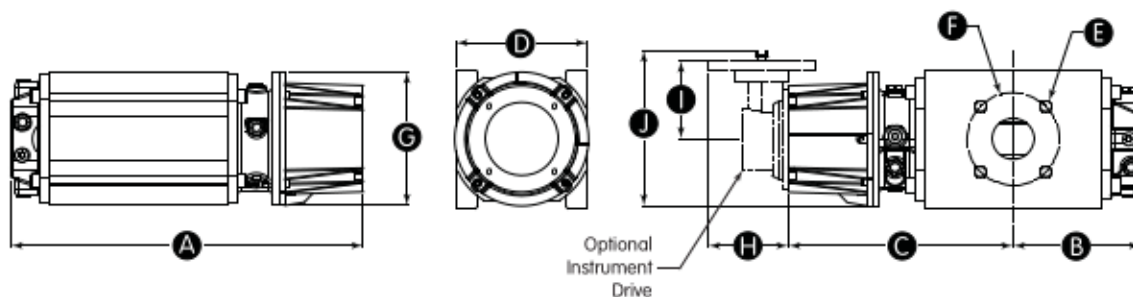



## RPM Series Rotary Meter Capacities - SCFH (Sm<sup>3</sup>/h)

Using the chart below, select the appropriate rotary meter by using the Maximum Instantaneous Flow Rate (SCFH) and the Minimum Operating Pressure (PSIG) at any given point in time.

Example: A maximum flow rate of 25,000 SCFH and an operating pressure range of 75-100 PSIG would require a 5.5M meter based on a 75 PSIG minimum inlet pressure.

Inlet Pressure	Meter Size						
	1.5M	2M	3.5M	5.5M	7M	11M	16M
	G25	G40	G65	G100	G130	G200	G250
0.25 PSIG (17 mBarg)	1,500 (42.0)	2000 (56.0)	3500 (98.0)	5500 (154.0)	7000 (196.0)	11,000 (308.0)	16,000 (448.0)
2 PSIG (140 mBarg)	1670 (46.8)	2227 (62.3)	3897 (109.1)	6124 (171.5)	7794 (218.2)	12,247 (342.9)	17,814 (498.8)
5 PSIG (345 mBarg)	1976 (55.3)	2634 (73.8)	4610 (129.1)	7244 (202.8)	9219 (258.1)	14,487 (405.6)	21,073 (590.0)
10 PSIG (690 mBarg)	2485 (69.6)	3313 (92.8)	5798 (162.3)	9111 (255.1)	11,595 (324.7)	18,221 (510.2)	26,504 (742.1)
25 PSIG (1.7 Barg)	4012 (112.3)	5350 (149.8)	9362 (262.1)	14,711 (411.9)	18,724 (524.3)	29,423 (823.8)	42,797 (1,198.3)
50 PSIG (3.4 Barg)	6558 (183.6)	8744 (244.8)	15,302 (428.5)	24,046 (673.3)	30,604 (856.9)	48,092 (1,346.6)	69,952 (1,958.7)
75 PSIG (5.2 Barg)	9104 (254.9)	12,138 (339.9)	21,242 (594.8)	33,381 (934.7)	42,485 (1,189.6)	66,762 (1,869.3)	97,108 (2,719.0)
100 PSIG (6.9 Barg)	11,650 (326.2)	15,533 (434.9)	27,183 (761.1)	42,716 (1,196.0)	54,365 (1,522.2)	85,431 (2,392.1)	124,263 (3,479.4)
150 PSIG (10.3 Barg)	16,741 (468.8)	22,322 (625.0)	39,063 (1093.8)	61,385 (1718.8)	78,126 (2187.5)	122,770 (3437.6)	178,574 (5000.1)
175 PSIG (12.1 Barg)	19,287 (540.0)	25,716 (720.1)	45,003 (1260.1)	70,720 (1980.1)	90,007 (2520.2)	141,439 (3960.3)	205,730 (5760.4)
200 PSIG (13.8 Barg)	21,833 (680.6)	29,111 (907.5)	50,944 (1588.1)	80,054 (2495.7)	101,887 (3176.3)	160,109 (4991.3)	232,885 (7260.1)
250 PSIG (17.2 Barg)	26,925 (753.9)	35,900 (1005.2)	62,824 (1759.1)	98,724 (2764.3)	125,648 (3518.2)	197,447 (5528.5)	287,196 (8041.5)
285 PSIG (19.6 Barg)	30,489 (853.7)	40,652 (1138.2)	71,141 (1991.9)	111,792 (3130.2)	142,281 (3983.9)	223,585 (6260.4)	325,214 (9106.0)

Capacity data based upon natural gas with specific gravity of 0.60.

## Ordering Information

	Meter Size						
	1.5M	2M	3.5M	5.5M	7M	11M	16M
	G25	G40	G65	G100	G130	G200	G250
Models	CTR, CID, CMTc, TCID, CRVP, TRVP (see page 3)						
Register	English or Metric 4, 5 or 6 Digit (see page 3)						
Connection (ANSI Flanged)	2"	2"	2"	2" or 3"	3"	4"	4"
Mounting	Vertical or Horizontal						
Carton size	16"H x 12"W x 21.5"L				16"H x 13"W x 24"L		
Shipping weight (lbs.)	33	30	30	42	65	75	90
(kg.)	(14.97)	(13.61)	(13.61)	(19.05)	(29.48)	(34.02)	(40.82)