

Quantometer MZ

MZ meters are flow meters. The flow of gas turns the turbine wheel, and thus the rotating speed of the turbine is proportional to the linear speed of the gas.

The movement is mechanically transmitted to the totaliser through a magnetic coupling.

Description

The MZ meter is composed of five main parts:

- > a body part containing all the component;
- > a flow straightener to stabilise and accelerate the flow before the turbine wheel (2)
- > a measuring unit including the turbine wheel;
- > a magnetic coupling to transmit the movement of the turbine wheel to the totaliser (4)
- > a totaliser to register the measured gas (5)

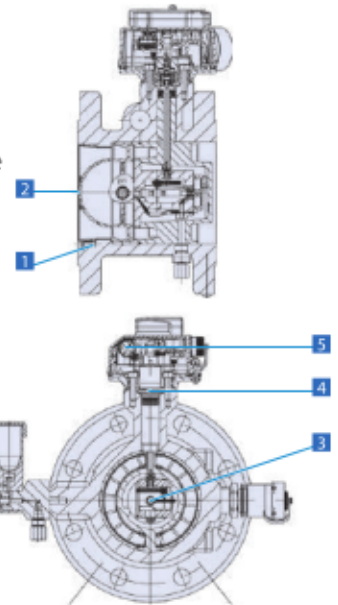

Applications

MZ meters are designed to measure natural gas, and various filtered, and non-corrosive gases. They are used to measure low to medium and high flow, at low or medium, or high pressure. They have been especially designed for industrial use and for secondary measurement. The possibility of fitting various options such as the oil pump or the PTFE coating version, means that they are also suitable for use in heavy duty measurement.

Features

Intrinsic safety approval	L.C.I.E. 06 ATEX 6031 X
Flow rate	From 6 m ³ /h to 10000 m ³ /h
Nominal diameters	From DN 2" to 16", 50 to 400 mm
Material	Ductile iron, cast steel or welded steel. Compliant with the Pressure Equipment Directive 97/23/EC
Maximum working pressure	Up to 100 bar depending on the body material and flanging.
Temperature range	Ambient: -30°C to +60°C Gas: -30°C to +60°C Storing temperature: 0°C to +70°C
Metrology	The tolerance of acceptance is +/-1.5% from Qmin to Qmax.



- > High accuracy budget meter
- > Flow rate up to 10000 m³/h
- > Pressure range up to 100 bar
- > Equipped as standard with the cycle target.
- > Various options available:
Low and high frequency transmitters, thermowell, oil pump, version for aggressive gases, etc.

Typical calibration curve

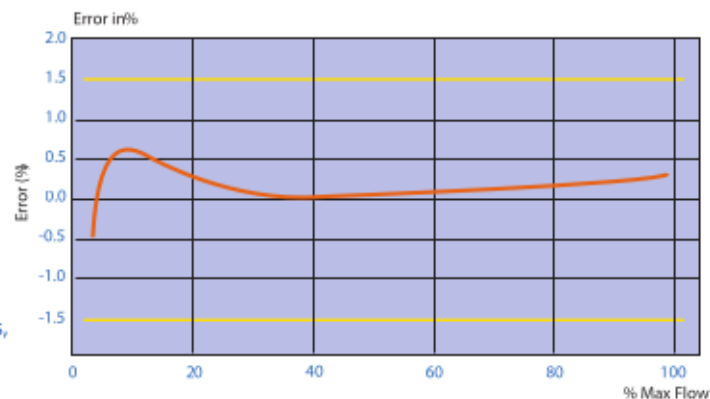



> Quantometer MZ DN150, Qmax: 1600m³/h

Totaliser:

- 9-digit index to register a larger volume
- 45° orientation for an easy reading
- Equipped as standard with the cyble target: it allows the installation of the cyble sensor at any time.
- Free-rotating totaliser
- Equipped with 1 built-in silicagel cartridge
- Fitted with a reflecting disc on the first drum
- IP67 protection
- UV resistant cover
- Unit: m³



Universal totaliser fitted as standard with the Cyble target

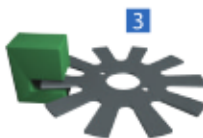
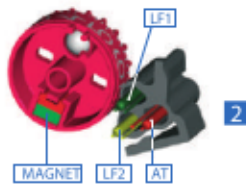

Transmitters

- 1 Cyble sensor: it can be delivered mounted on the meter or installed afterwards at any time. The Cyble sensor is a bounce-free transmitter. It allows also the counting of eventual back flows.
- 2 Low Frequency (LF): two Reed switches are fitted as an option on the whole range. Anti-tampering (AT): this device is fitted as an option on the whole range.
- 3 Medium Frequency (MF): one transmitter is supplied as an option.
- 4 High Frequency (HF): a transmitter is supplied as an option on the whole range, and it is fitted close to the turbine wheel.

Thermowell

The thermowell can be installed as an option on the meter. It allows the gas temperature to be measured at the reference point. (Installation of a thermowell cannot be done into a meter equipped with HF transmitter)

Volume converter

It can be installed directly onto the meter thanks to a mounting kit

Pressure tapping:

This device allows the gas pressure to be measured at the reference point. It is installed as standard.

Oil pump

5 It lubricates the ball bearings in the measuring unit. The oiling can be done even when the meter is under pressure. The oil reservoir can be easily turned to fit with vertical installed meters.

Measurement of aggressive gases:

A version with a PTFE (Teflon) coating, is available, as an option. The coating is applied on the internal parts of the meter.

Turbine wheel

6 This is the most important component of the meter for achieving high accuracy at low and high pressure. It can be made in aluminium for the whole range or in polyacetal for the DN<200. Depending on the maximum flow rate, the blade of turbine wheel is oriented at 45° or 60°. Turbine wheel at 60° is used to avoid over-speed of the wheel. When a HF is requested, the wheel must be in aluminium. For high pressure use, or for measuring dirty gases, an aluminium wheel is recommended.

Characteristics

A) Technical data sheet

Rangeability and pulse values

With correction gears 32/40 (correction 0%)										
DN (mm)	Max Flow (m³/h)	Min Flow (m³/h)	Pressure loss (mbar) ρ = 0.8 kg/m³	1 Imp LF & Cyble (m³/Imp)	Freq LF (Hz)	1 Imp MF (dm³/Imp)	Freq MF (Hz)	1 Imp HF (dm³/Imp)	Freq HF (Hz)	RPM (Rot/min)
50	100	6	8.1	0.1	0.28	5.8947	4.71	0.00970	2864	14322
80	160	10	2	1	0.04	23.07692	1.93	0.03797	1171	5853
250	16	4.8	0.07	23.07692	3.01	0.03797	1829	9146		
400	25	11	0.11	39.11111	2.84	0.06434	1727	8634		
100	250	16	2	1	0.07	23.07692	3.01	0.06271	1107	4153
400	25	4.8	0.11	23.07692	4.81	0.06271	1772	6644		
650	40	11	0.18	39.11111	4.62	0.10628	1699	6371		
150	650	40	1.5	1	0.18	23.07692	7.82	0.15385	1174	3521
1000	65	4.3	0.28	23.07692	12.04	0.15385	1806	5417		
1600	100	9	0.44	39.11111	11.36	0.26074	1705	5114		
200	1000	65	1.5	10	0.03	230.7692	1.2	0.37661	738	2213
1600	100	4.3	0.04	230.7692	1.93	0.37661	1180	3540		
2500	160	9	0.07	391.1111	1.78	0.63829	1088	3264		
250	1600	100	1.5	10	0.04	230.7692	1.93	0.5787	768	1920
2500	160	4.3	0.07	230.7692	3.01	0.5787	1200	3000		
4000	250	9	0.11	391.1111	2.84	0.9808	1133	2832		
300	2500	160	1.5	10	0.07	218.1818	3.18	0.85763	810	1735
4000	250	4.3	0.11	218.1818	5.09	0.85763	1296	2776		
6500	400	9	0.18	391.1111	4.62	1.53739	1174	2517		
400	4000	250	1.5	10	0.11	218.1818	5.09	2.04673	543	1163
6500	400	4.3	0.18	218.1818	8.28	2.04673	882	1890		
10000	650	9	0.28	391.1111	7.1	3.66896	757	1622		

Body construction

DN (mm)	ISO PN 10	ISO PN 16	ISO PN 25	ISO PN 40	ISO PN 20 ANSI 150	ISO PN 50 ANSI 300	PN 110 ANSI 600
50	A	A	A	A	A	-	-
80	A	A	A	A	A	C	C
100	B	B	B	B	B	C	C
150	B	B	B	B	B	C	C
200	B	B	C	C	B	C	C
250	D	D	D	D	D	D	D
300	D	D	D	D	D	D	D
400	D	D	D	D	D	D	D

- A: EN-GJS-400-18LT Sandwich body
- B: EN-GJS-400-18LT flanges body
- C: Steel Sandwich body
- D: Steel flanges body (cast or welded)

Note: for the pressure and temperature range of the body material, please check your National Rules

B) Calculation of the extended rangeability

When the density of the measured gas ρ_{RC} : minimum flowrate³(h) for a density increases, the minimum measured flow rate of 1.2 kg/m³ decreases.

This minimum flow rate in real conditions ρ_{RC} : density of the gas in real conditions³kg/m³ > Where:

(QminRC) can be evaluated using the following formula: $Q_{minRC} = Q_{min1.2} \times \sqrt{\frac{1.2}{\rho_{RC}}}$

formula:

- Δp : Pressure loss in the calculated conditions
- Δp_r : Pressure loss in the reference conditions
- ρ_n : Gas density (kg/m³) at 0° C and 1013 mbar
- P_b : Operating pressure (Bar gauge)
- q : Flow rate (m³/h)
- Q_{max} : Maximum flow rate³(h)
- T_b : Gas temperature (°C).

C) Pressure loss of the MZ meters

Values: see table above

Calculation of pressure loss: $\Delta p = \Delta p_r \times \frac{\rho_n}{0.83} \times (P_b + 1) \times \left[\frac{q}{Q_{max}} \right]^2 \times \left[\frac{273}{(273 + T_b)} \right]$

D) Dimensions (mm) and weights

DN	L	A	B	ISO PN 10 - ISO PN 40 ANSI 150				ISO PN 50 - ISO PN 110 ANSI 300 / ANSI 600			
				C	D	E	Kg	C	D	E	Kg
50	60	15	18	156	160	163	4	-	-	-	-
80	120	35	34	173	180	176	10	165	180	176	32
100	150	54	28	209	180	186	19	186	190	195	47
150	200	71	48	238	225	216	33	221	230	230	78
200	200	69	43	273	250	277	85	252	265	261	120
250	300	89	90	287	292	275	100	376	284	275	140
300	300	78	97	289	320	306	125	403	350	388	185
400	400	132	120	360	326	356	220	360	383	356	310

E) Transmitter characteristics

Intrinsic safety approval: L.C.I.E. 06 ATEX 6031 X

Intrinsic safety level: II 1/2 G Ex ia IIC T5 c T6

Low Frequency pulse transmitter (LF):

The LF transmitter consists of 2 dry Reed switches, normally open, and controlled by a magnet situated in the first drum of the totalizer. The LF connections are without polarity.

Inductive transmitters (MF and HF):

They are inductive sensors actuated by a toothed disc. The frequency is proportional to the instantaneous flow. The polarity of the connections is indicated on the name plate of the meter.

Characteristics of LF transmitter:

- > Hermetically sealed contacts
- > Maximum terminal voltage: 30 Volt and maximum current according to EN 60079-11.
- > Maximum temperature: +60°C
- > Minimum pulse time: 0.4 sec
- > Cyble sensor: It conforms to CENELEC standard EN 60079-11 with:
 - $U_i \leq 14.3$ Volt
 - $I_i \leq 50$ mA

Characteristics of MF and HF transmitters:

- > Proximity detector conform to EN 60947-5-6 (NAMUR) standards
- > They conform to CENELEC standards (EN 60079-0 and EN 60079-11) with:
 - $U_i \leq 16$ Volt
 - $I_i \leq 52$ mA
 - $C_i \leq 50$ nF
 - $L_i \leq 250$ μ H
 - $P_i \leq 64$ mW
- > Maximum temperature: + 60°C

Anti-tampering transmitter (AT):

This consists of one dry Reed switch, normally closed. Attempts at magnetic tampering will open the contact. The electrical characteristics are the same as those for the LF transmitter.

F) Installation

Each meter is delivered with binder plugs for the installed transmitters and oil when an oil pump is installed. Please refer to the instruction manual supplied with the meter.

The advice given therein will ensure optimal use of the MZ quantummeter over the years.

