

# Rotary Meter Delta<sup>®</sup>

- ▶ **Excellent metrological stability attested by customers over the years**
- ▶ **No influence of installation conditions nor stop-and-go flow rate on the metrology**
- ▶ **Large rangeability approved by the DRIRE, NMI, PTB and various other official bodies**
- ▶ **Optimised pressure loss for low pressure network**
- ▶ **Available in aluminium, ductile iron, or steel, for all applications**



- ▶ **Delta DN50 G65 in aluminium equipped with 2 thermowells**

Delta meters are volumetric meters. The flow of gas moves the pistons and each rotation traps and transfers a specific volume of gas.

The movement is mechanically transmitted to the totaliser through the magnetic coupling.

## Description

A Delta meter is made of 5 main parts:

- ▶ A measuring chamber that is limited by the body and the 2 base plates (1)
- ▶ 2 pistons, which are synchronised by 2 gears and which rotate in opposite directions (2)
- ▶ 2 lubricant covers (3)
- ▶ A magnetic coupling to transmit the movement of the pistons to the totaliser (4)
- ▶ A totaliser to register the counted gas (5)

## Applications

Delta meters are designed to measure natural gas and various filtered, and non-corrosive gases. They are used when very accurate measurement is required, when the gas flow can be low or irregular. Due to the volumetric principle of the Delta meter, its metrology is not influenced by installation conditions. Consequently, it can be used to build very compact stations without installing a straight pipe inlet before the meter.

Delta meters are approved for fiscal use.

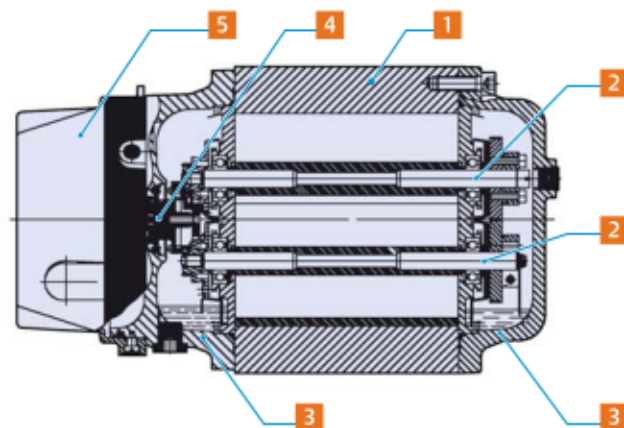



► Delta DN50 G65 in aluminium equipped with 2 thermowells

## Features

<b>Flow rate</b>	from 0.4 m <sup>3</sup> /h to 1000 m <sup>3</sup> /h, G10 to G650	
<b>Nominal Diameters</b>	from DN 40 to 150 mm (1 1/2 to 6")	
<b>Maximum working pressure</b>	up to 94 bar depending on the body material and flanging	
<b>Body materials</b>	aluminium (profile or cast), cast iron or cast steel. Compliant with the Pressure Equipment Directive 97/23/EC	
<b>Temperature range</b>	Ambient	-20° C to +60° C
	Gas	-20° C to +60° C
	Storing temperature: -40° C to +70° C	
<b>Metrology</b>	in accordance with the EC and OIML, large rangeability up to 1200, depending on the G-size (see §6) Approvals EC (PTB): 1.33-3271.3-ROM-E11. Large rangeability (PTB): 1.33-3271.3-ROM-N05	
<b>Intrinsic safety approval</b>	LCIE 02 ATEX 6254 X - Compliant with the Directive 94/9/EC.	

In accordance with the EC regulation, the maximum permissible error is +/-2% from Qmin to 0.2 Qmax, and +/-1% from 0.2 Qmax to Qmax. The WME (Weighted

Measured Error) is less than 0.4%. Typical Actaris accuracy is +/-1% from Qmin to 0.2 Qmax, +/-0.5% from 0.2 Qmax to Qmax.

### ► Typical calibration curve

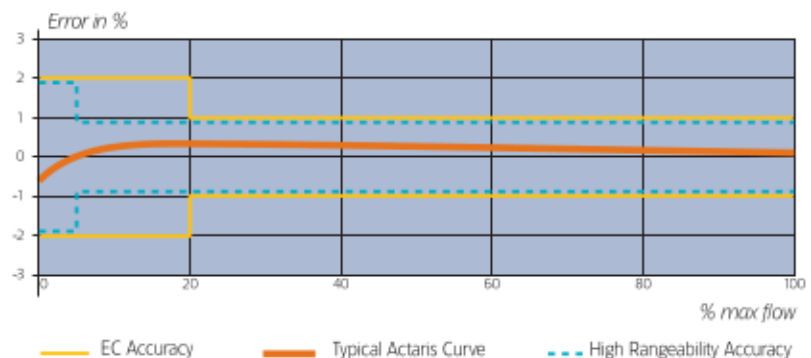

► Delta DN50 G65 in aluminium equipped with a lateral totalizer

### ► Totaliser:

- 9-digit index for a large capacity
- IP67 protection
- UV resistant cover
- Equipped with a built-in silicagel cartridge. As an option, it can be equipped with an external one, allowing easy maintenance even in extreme conditions
- Orientation can be adjusted without decommissioning the meter (except 2040, see page 3)
- Fitted with a reflecting disc on the first drum
- Integrated optical disc to facilitate the periodic calibration of the meter

- Customised name plate (bar code, logo, customer serial number...)
- Unit: m<sup>3</sup> or Cf<sup>3</sup>.
- Lateral totalizer available as an option.

### ► Transmitters:

- Double Low Frequency fitted as standard on the whole range
- Anti-tampering is supplied as standard on 2050/2080/2100 (see page 4)
- High Frequency is supplied as an option on the whole range.

## Accessories

- 100 µm flat **gasket-filter** to fit between flanges DN50, DN80, DN100 and DN 150.
- **External silicagel cartridge**: accessory for maintenance on the installed external silicagel cartridge for extreme conditions.
- **Flange** DN50 PN10/16-ANSI125, can be delivered to adapt a 2040 meter (thread connection) to flange connections DN50. This gives a flange-to-flange distance of 171 mm.
- **Pete's plug<sup>®</sup>**: ideal device for filling lubricant in the cover of the meter while equipment is in service. It must be fitted instead of the tap plug of the cover. Plugged on the pressure tapping, it can be used to measure the pressure and the temperature of the measured gas. Connection size: 1/4" NPT or 1/4" BSP. Maximum pressure of gas: 30 bar.
- **Bracket for mounting a volume converter**: this device permits the Actaris Corus PTZ volume converter to be adapted directly onto the meter, or at the most convenient place to the meter to enable the converter index to be easily read.
- **Thermowells**: these thermowells threaded 1/4" NPT, can be plugged onto the meter. They are retrofitable on the standard version (plugged onto the existing pressure tapping), or they can be installed on the versions equipped with extra-tapping. The internal diameter of the thermowell is 7 mm; it allows the mounting of the most standard temperature probes.

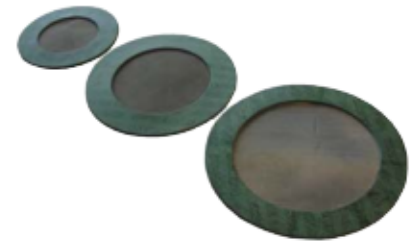

► Gasket filters from DN50 to DN150



► Delta DN100 G250 with Corus PTZ

## Delta 2040 - Aluminium

### Features

Flow rate	0.5 m <sup>3</sup> /h to 65 m <sup>3</sup> /h
G size	G10, G16, G25 and G40
Rangeability	1.20 to 1.50 (see table, page 6)
Nominal diameter	40 mm (1 1/2)
Flanging	thread BSP or NPT
Pressure range	12 bar

### Main characteristics

- Very compact meter, ideal for mounting in an extremely small cabinet.
- Only the front cover has to be filled with lubricant.
- Totaliser in gas, no magnetic coupling - integral tightness.
- Horizontal mounting, inlet left or inlet right or vertical mounting, inlet top or inlet bottom (to be specified when ordering).
- Double LF connected on Binder 6 pins or Fischer plug, no anti-tampering. For hydrogen version, LF is not available.
- HF is supplied as an option, connected on the same plug as the LF.
- Flange DN50 PN10/16-ANSI125 can be delivered to adapt a 2040 meter (thread connection) to flange connections DN50. This gives a flange-to-flange distance of 171 mm.



► Delta 2040 - Aluminium



► Delta 2050/2080/2100 - Aluminium

## Delta 2050/2080/2100 - Aluminium

### Features

Flow rate	0.4 m <sup>3</sup> /h to 400 m <sup>3</sup> /h
G size	G16, G25, G40, G65, G100, G160 and G250
Rangeability	1.20 to 1.200 (see Table, page 6)
Nominal Diameter	50mm, 80mm and 100mm (2", 3" and 4")
Flanging	PN 10/16, PN20 and ANSI125 Note: flange connection ANSI125 is geometrically identical to ANSI150
Pressure range	16 bar

### Main characteristics

- Index can be oriented as required, magnetic coupling.
- Both front and rear covers must be filled with a lubricant.
- Multi-position meters, the flow orientation does not need to be specified when ordering the meter.
- Thermowells: supplied as an option, 2 tapings 1/4" NPT allow an easy installation of thermowells.
- Double retrofit LF (it can be changed without decommissioning the meter), connected on Binder 6 pins or Fischer plug. Anti-tampering is supplied as a standard.
- HF is supplied as an option, connected on a binder 3 pins.
- A G100 DN50 is available to allow the possibility of increasing the station capacity; the use of the same flanging as the G65 DN50 does not require modification of the existing installation.

## Delta 2050/2080/2100 - Ductile iron

EN-GJS-400-18LT (GGG40.3)

### Features

Flow rate	0.4 m <sup>3</sup> /h to 400 m <sup>3</sup> /h
G size	G16, G25, G40, G65, G100, G160 and G250
Rangeability	1.20 to 1.200 (see Table, page 6)
Nominal Diameter	50mm, 80mm and 100mm (2", 3" and 4")
Flanging	PN 10/16, PN20 and ANSI150
Pressure range	17.2 bar

### Main characteristics

- Index can be oriented as required, magnetic coupling.
- Both front and rear covers must be filled with a lubricant.
- Multi-position meters, the flow orientation does not need to be specified when ordering the meter.
- Thermowells: supplied as an option, 2 tapings 1/4" NPT allow an easy installation of thermowells.
- Double retrofit LF (It can be changed without decommissioning the meter) connected on Binder 6 pins or Fischer plug. Anti-tampering is supplied as a standard.
- HF is supplied as an option connected on a Binder 3 pins.
- High Temperature Loading: fire resistant PN4 is supplied as an option.



► Delta 2050/2080/2100 - Ductile iron  
EN-GJS-400-18LT (GGG40.3)



## Delta 3D and N – Cast iron FGL 250 (GG25)

### Features

Flow rate	13 m <sup>3</sup> /h to 1000 m <sup>3</sup> /h
G size	G400 and G650
Rangeability	1.20 to 1.50 (see Table, page 6)
Nominal Diameter	150 mm (6")
Flanging	PN 10/16, PN20 and ANSI125 Note: flange connection ANSI125 is geometrically identical to ANSI150
Pressure range	12 bar

### Main characteristics

- Index can be oriented as required, magnetic coupling.
- Both front and rear covers must be filled with a lubricant.
- G400: Multi-position meter, the flow orientation does not need to be specified when ordering the meter.
- G650: Horizontal mounting, inlet left or inlet right or vertical mounting, inlet top or inlet bottom (to be specified when ordering).
- Double LF connected on Binder 6 pins or Fischer plug, no anti-tampering.
- HF is supplied as an option connected on the same plug as the LF.



► Delta 3D and N  
Cast iron FGL 250 (GG25)

## Delta 2050/2080/2100 – Steel

### Features

Flow rate	0.4 m <sup>3</sup> /h to 400 m <sup>3</sup> /h
G size	G16, G25, G40, G65, G100, G160 and G250
Rangeability	1.20 to 1.200 (see Table, page 6)
Nominal diameter	50mm, 80mm and 100mm (2", 3" and 4")
Flanging	PN 10/16 to PN110, ANSI 150 to ANSI600
Pressure range	94 bar

### Main characteristics

- Index can be oriented as required, magnetic coupling.
- Both front and rear covers must be filled with a lubricant.
- Horizontal inlet left-vertical inlet top or horizontal inlet right-vertical inlet bottom (to be specified when ordering).
- Double retrofit LF (it can be changed without decommissioning the meter) connected on Binder 6 pins or Fischer plug. Anti-tampering is supplied as a standard.
- HF is supplied as an option connected on a binder 3 pins.
- Special version for oxygen available.



► Delta 2050/2080/2100 – Steel

# Characteristics

## A) Technical data sheet Rangeability and pulse values

G size	DN (mm)	Max Flow (m³/h)	Type	Material	Rangeability <sup>(1)</sup>	Q start (dm³/h)	Flow rate at Error = -10% Typical value (dm³/h)	1 Imp LF (m³/Imp)	1 Imp HF (dm³/Imp)	Freq HF at Qmax (HZ)	Pmax (bar)	1"1/2 BSP	1"1/2 NPT	ISO PN 10-16	ISO PN 20	ISO PN 25	ISO PN 40	ISO PN 50	ISO PN 110	ANSI 125	ANSI 150	ANSI 300	ANSI 600
G10	40	16	2040/A	Aluminium	20 to 30	30	100	0.01	0.0227	195	12	•	•										
G16	40	25	2040/A	Aluminium	20 to 50	30	100	0.01	0.0227	305	12	•	•										
	50	25	2050/A	Aluminium	20 to 50	50	150	0.1	0.3287	21	16			•	•					•			
	50	25	2050/B	EN-GJS-400-18LT	20 to 50	50	150	0.1	0.3287	21	17.2			•	•						•		
G25	50	25	2050/C	Steel	20 to 50	50	150	0.1	0.3287	21	94			•	•	•	•	•	•		•	•	•
	40	40	2040/A	Aluminium	20 to 50	50	150	0.01	0.0324	343	12	•	•										
	50	40	2050/A	Aluminium	20 to 100	50	150	0.1	0.3287	34	16			•	•					•			
G40	50	40	2050/B	EN-GJS-400-18LT	20 to 100	50	150	0.1	0.3287	34	17.2			•	•						•		
	50	40	2050/C	Steel	20 to 100	50	150	0.1	0.3287	34	94			•	•	•	•	•	•		•	•	•
	40	65	2040/A	Aluminium	20 to 50	50	200	0.01	0.0324	558	12	•	•										
G65	50	65	2050/A	Aluminium	20 to 160	50	150	0.1	0.3287	55	16			•	•					•			
	50	65	2050/B	EN-GJS-400-18LT	20 to 160	50	150	0.1	0.3287	55	17.2			•	•						•		
	50	65	2050/C	Steel	20 to 160	50	150	0.1	0.3287	55	94			•	•	•	•	•	•		•	•	•
G100	50	100	2050/A	Aluminium	20 to 200	50	150	0.1	0.3287	85	16			•	•					•			
	50	100	2050/B	EN-GJS-400-18LT	20 to 200	50	150	0.1	0.3287	85	17.2			•	•						•		
	50	100	2050/C	Steel	20 to 200	50	150	0.1	0.3287	85	94			•	•	•	•	•	•		•	•	•
G160	80	160	2080/A	Aluminium	20 to 200	70	250	0.1	0.3287	135	16			•	•					•			
	80	160	2080/B	EN-GJS-400-18LT	20 to 200	70	250	0.1	0.3287	135	16			•	•						•		
	80	160	2080/C	Steel	20 to 30	150	500	1	0.4095	109	94			•	•	•	•	•	•		•	•	•
	80	160	2080/A	Aluminium	20 to 200	80	250	0.1	0.3287	211	16			•	•					•			
G250	80	250	3080/A	Aluminium	20 to 160	150	500	1	0.4095	170	16			•	•					•			
	80	250	3080/B	EN-GJS-400-18LT	20 to 160	150	500	1	0.4095	170	17.2			•	•						•		
	80	250	3080/C	Steel	20 to 50	150	500	1	0.4095	170	94			•	•	•	•	•	•		•	•	•
	100	250	3100/B	EN-GJS-400-18LT	20 to 200	80	250	0.1	0.3287	211	17.2			•	•						•		
G400	100	300 <sup>(2)</sup>	2100/A	Aluminium	20 to 160	280	780	1	11599	72	16			•	•					•			
	100	400	2100/A	Aluminium	20 to 160	200	600	1	11603	96	16			•	•					•			
	100	400	2100/B	EN-GJS-400-18LT	20 to 160	200	600	1	11603	96	17.2			•	•						•		
G650	100	400	2100/C	Steel	20 to 50	200	600	1	11603	96	94			•	•	•	•	•	•		•	•	•
	150	650	3D	FGL 250	20 to 50	600	1600	1	0.554	326	12			•	•					•			
G650	150	1000	N	FGL 250	20 to 50	1400	3300	1	0.877	317	12			•	•					•			

(1) For more than 1:20, see also your National Approval.  
 (2) Only National-approved.

**Note:** For the pressure range and the temperature range of the body material, please also check your national rules.

## B) Pressure loss of the DELTA meters

DN [mm]	Type	G-Size	Qmax [m³/h]	Pressure loss in the reference conditions ΔPr [mbar] ρ=0.83kg/m³, T=0° C, Qmax
40	2040/25	G10	16	0.34
	2040/25	G16	25	0.83
	2040/40	G25	40	1.38
	2040/65	G40	65	3.32
50	2050/100	G25	40	0.33
	2050/100	G40	65	0.88
	2050/100	G65	100	2.08
	2050/160	G100	160	3.25
80	2080/160	G100	160	1.73
	3080/250	G160	250	3.15
	2080/250	G160	250	2.73
100	3100/250	G160	250	3.15
	2100/400	G250	400	2.63
150	3D	G400	650	2.63
	N	G650	1000	4.01

Calculation of pressure loss:

$$\Delta p = \Delta p_r \times \frac{\rho_n}{0.83} \times (P_b + 1) \times \left[ \frac{q}{Q_{max}} \right]^2 \times \left[ \frac{273}{273 + T_b} \right]$$

► Where:

- Δp: Pressure loss in the calculated conditions
- Δp<sub>r</sub>: Pressure loss in the reference conditions
- ρ<sub>n</sub>: Gas density (kg/m³) at 0° C and 1013 mbar
- P<sub>b</sub>: Operating pressure (Bar gauge)
- q: Flow rate (m³/h)
- Q<sub>max</sub>: Maximum flow rate (m³/h)
- T<sub>b</sub>: Gas temperature (°C).

### C) Dimensions (mm), weights and Thermowell sizes

Series	G-size	Type	Mat.	Fig.	Kg	A	B	C	D	E	F	G	H
0	G10-G16	2040/25A	Aluminium	1	2.7	93	66	159	96	70	121	70	35
0	G25	2040/40A	Aluminium	1	3.4	103	86	189	96	100	121	80	45
0	G40	2040/65A	Aluminium	1	3.4	103	86	189	96	100	121	80	45
1	G16-G65	2050/100A	Aluminium	2	11	187	120	307	182	87	171	-	-
1	G16-G65	2050/100B	Ductile iron EN-GJS-400-18LT	3	19	187	120	307	174	87	171	-	-
1	G16-G65	2050/100C	Steel	4	53	186	118	304	175	120	300	-	-
1	G16-G100	2050/160B	Ductile iron EN-GJS-400-18LT	3	25	225	150	375	194	96	150	-	-
1	G100	2050-2080/160A	Aluminium	2	15	224	158	382	182	87	171	-	-
1	G100	2080/160B	Ductile iron EN-GJS-400-18LT	3	25	225	150	375	194	96	171	-	-
1	G100	2080/160B	Ductile iron EN-GJS-400-18LT	3	27	225	150	375	194	96	240	-	-
1	G160	3080/250A	Aluminium	2	17	248	180	428	182	87	171	-	-
1	G160	3080/250B	Ductile iron EN-GJS-400-18LT	3	30	248	180	428	182	87	230	-	-
1	G160	3100/250B	Ductile iron EN-GJS-400-18LT	3	30	248	180	428	182	87	230	-	-
1	G160	3100/250B	Ductile iron EN-GJS-400-18LT	3	30	248	180	428	182	87	241	-	-
2	G160	2080/250A	Aluminium	2	29	228	181	409	235	121	241	-	-
2	G160	2080/250B	Ductile iron EN-GJS-400-18LT	3	41	228	181	409	235	121	241	-	-
2	G160	2080/250LB	Ductile iron EN-GJS-400-18LT	3	45	228	181	409	235	121	310	-	-
2	G100-160	2080/250C	Steel	4	84	228	185	413	275	138	320	-	-
2	G160 300	2100/300A	Aluminium	2	34	263	216	479	235	121	241	-	-
2	G250	2100/450A	Aluminium	2	43	331	284	615	235	121	241	-	-
2	G250	2100/400B	Ductile iron EN-GJS-400-18LT	3	56	331	284	615	235	121	241	-	-
2	G250	2100/400LB	Ductile iron EN-GJS-400-18LT	3	61	331	284	615	235	121	400	-	-
2	G250	2100/400C	Steel	4	119	332	288	620	275	138	440	-	-
3	G400	3D150/650B	Cast iron FGL 250	5	104	375	290	665	308	157	450	225	170
3	G650	N150/1000B	Cast iron FGL 250	6-7	197	455	365	820	400	310	500	250	270

► **Figure 1**

2040/A G10-G16-G25-G40  
Material: Aluminium

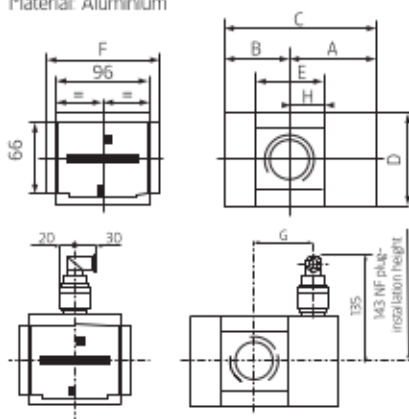

► **Figure 2**

2050/A G16-G25-G40-G65-G100;  
2080/A G100-G160, 3080/A G160, 2100/A G250  
Material: Aluminium

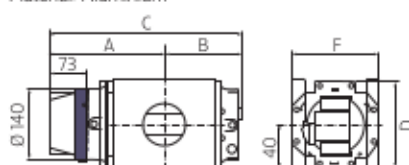

► **Figure 3**

2050/B G16-G25-G40-G65-G100;  
2080/B G100-G160, 2100/B G250  
Material: ductile iron EN-GJS-400-18LT

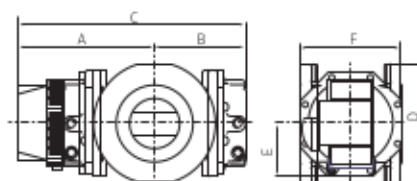

► **Figure 4**

2050/C G16-G25-G40-G65;  
2080/C G100-G160, 2100/C G250  
Material: Steel

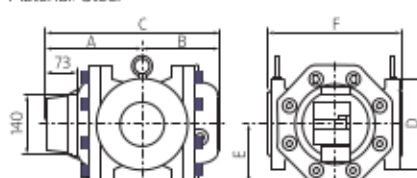

► **Figure 5**

3D Series: DN150 G400  
Material: cast iron FGL 250

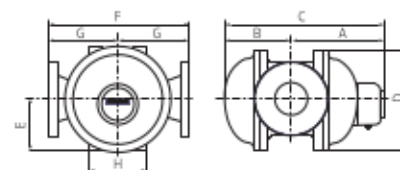

► **Figure 6**

N Series: DN150 G650 vertical  
Material: cast iron FGL 250

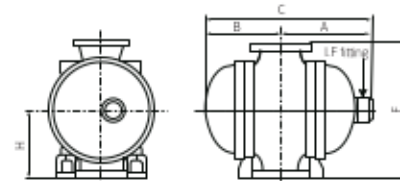

► **Figure 7**

N Series: DN150 G650 horizontal  
Material: cast iron FGL 250

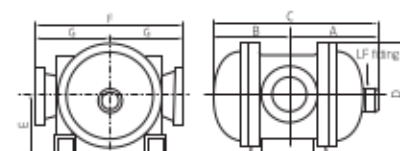

L1: E224-809-03 Length 65 mm  
L2: E224-809-04 Length 85 mm



► Thermowell fitted with sealing holes

### Installation

Each meter is delivered with binder plugs for the installed transmitters and oil for the lubrication. Please refer to the instruction manual provided with the meter. The advice contained therein will ensure the optimal use of the DELTA meter over the years.

### Thermowell sizes

Series	G-size	Type	Mat	Thermowell model	
				2 thermowells in prepared holes	1 for retrofit purpose
0	G10-G40	2040/xxA	Aluminium	*	-
1	G16-G25-40-G65	2050/100A	Aluminium	L1	L2
1	G16-G25-G40-G65	2050/100B	Ductile iron EN-GJS-400-18LT	L2	L2
1	G16-G25-G40-G65	2050/100C	Steel	-	-
1	G100	2050-2080/160A	Aluminium	L1	L2
1	G100	2080/160B = 171 mm	Ductile iron EN-GJS-400-18LT	L2	L2
1	G100	2080/160B = 240 mm	Ductile iron EN-GJS-400-18LT	L1	L2
1	G160	3080/250A	Aluminium	L1	L2
1	G160	3080-3100/250B	Ductile iron EN-GJS-400-18LT	L2	L2
2	G160	2080/250A	Aluminium	L1	L2
2	G160	2080/250B	Ductile iron EN-GJS-400-18LT	L1	L1
2	G100-G160	2080/250LB	Ductile iron EN-GJS-400-18LT	L1	L1
2	G100-G160	2080/250C	Steel	-	-
2	G250	2100/450A	Aluminium	L1	L2
2	G250	2100/400B	Ductile iron EN-GJS-400-18LT	L1	L1
2	G250	2100/400LB	Ductile iron EN-GJS-400-18LT	L1	L1
2	G250	2100/400C	Steel	-	-
3	G400	30150/650B	Cast iron GG 25	L2	L2
3	G650	N150/1000B	Cast iron GG 25	L2	L2

\* upon special request only

### D) Transmitter characteristics

Intrinsic safety approval N° LCIE 02 ATEX 6254 X

#### Low frequency pulse transmitter (LF):

The LF transmitter consists of 2 dry, normally open, Reed switches, controlled by a magnet situated in the first drum of the totaliser. The LF connections do not have polarity.

#### Characteristics

- Intrinsic safety level:
  - ⊕ II 1/2 G EEx ia IIC T6
- Hermetically sealed contacts
- Maximum terminal voltage : 30 Volt and maximum current according to EN 50020, as example:
  - 30 Volt - 101 mA
  - 24 Volt - 174 mA
  - 18.5 Volt - 402 mA
- Maximum temperature: + 60°C
- Minimum pulse duration: 0.4 s

#### Anti-tampering transmitter (AT):

This consists of one dry Reed switch, normally closed. Magnetic tampering attempts will open the contact. The electrical characteristics are the same as for the LF transmitter.

#### High frequency pulse transmitter (HF):

This is an inductive sensor actuated by a toothed disc. The frequency is proportional to the instantaneous flow. The polarity of connections is represented on the name plate of the meter.

#### Characteristics

- Intrinsic safety level:
  - ⊕ II 1/2 G EEx ia IIC T6
- Proximity detector conform to EN50227 (and NAMUR) standards
- They conform to CENELEC standards (EN50014 and 50020) with:
  - Ui ≤ 16 Volt
  - Ii ≤ 25 mA
  - Pi ≤ 64 mW
- Maximum temperature: + 60°C