

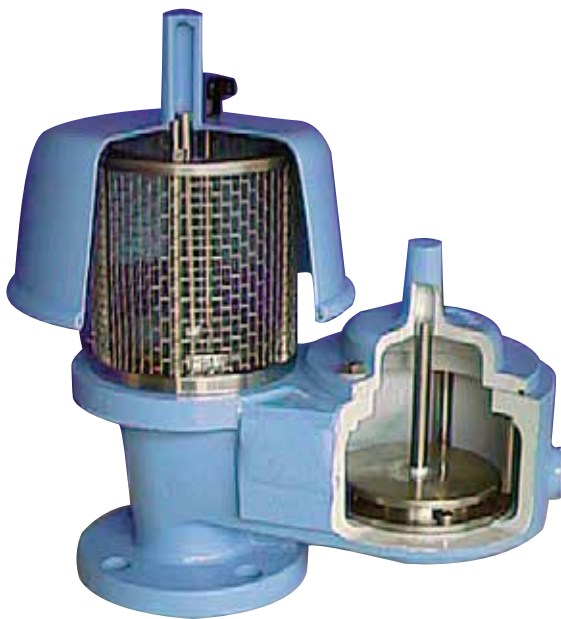

ANDERSON GREENWOOD MARVAC SERIES 121 PRESSURE AND VACUUM RELIEF VALVES

Weight or spring loaded valves capable of providing pressure and vacuum relief that vent to atmosphere



FEATURES

- Weight or spring loaded models available.
- Choice of body materials.
- Removable stainless steel seats.
- Low ambient temperature version available.
- Full flange.
- ANSI and DIN flanges.
- Self draining body.

GENERAL APPLICATION

Series 121 valves provide pressure and vacuum relief in storage tank farms, the petroleum and chemical sectors and for the protection of anaerobic waste digesters.

TECHNICAL DATA

Materials:	Aluminum, carbon steel, stainless steel
Sizes:	2" to 12" (DN 50 to 300)
Pressure settings:	2.5 mbar to 3.5 bar
Vacuum settings:	2.5 mbar to 800 mbar



ANDERSON GREENWOOD MARVAC SERIES 121 PRESSURE AND VACUUM RELIEF VALVES

DIMENSIONS AND WEIGHTS

121 WEIGHT LOADED PRESSURE AND VACUUM

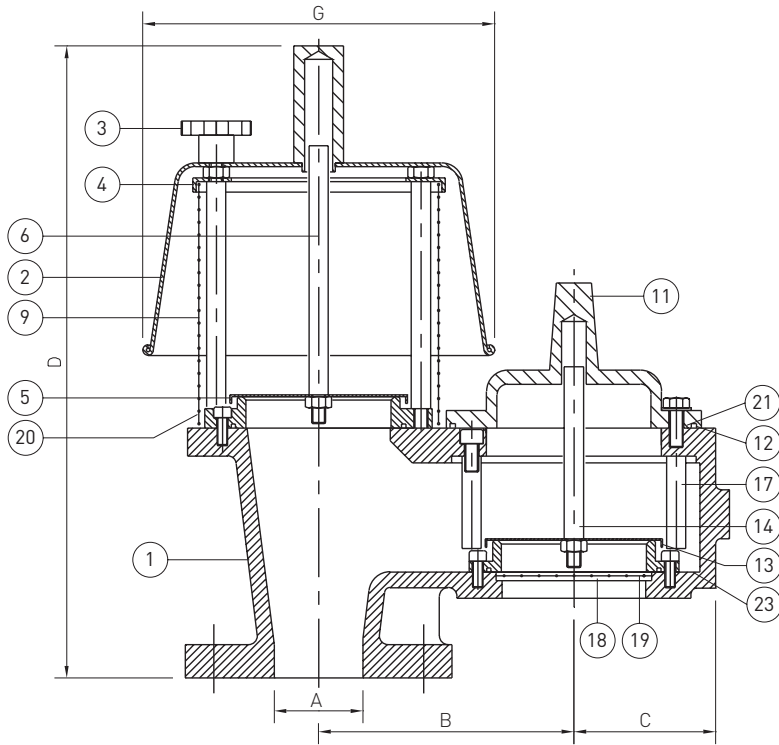

PARTS LIST

Item	Description	Alum spec	C. steel	SS spec
1	Valve body	Aluminum	WCB	316 SS
2	Weather hood	Aluminum	Steel	Steel
3	W/hood handnuts	Phenolic	Phenolic	Phenolic
4	Spacer ring	Aluminum	Steel	316 SS
5	Press pallet	316 SS	316 SS	316 SS
6	Press pallet stem	316 SS	316 SS	316 SS
7	Diaphragm	PTFE	PTFE	PTFE
8	Diaphragm back/disc	Non asbestos	Non asbestos	Non asbestos
9	Press. guide posts	316 SS	316 SS	316 SS
10	Diaphragm suport disc	316 SS	316 SS	316 SS
11	Vacuum cover	Aluminum	W.C.B	316 SS
12	O-ring seal	Nitrile	Nitrile	Nitrile
13	Vacuum pallet	316 SS	316 SS	316 SS
14	Vac. pallet stem	316 SS	316 SS	316 SS
15	Vac. pallet diaph.	PTFE	PTFE	PTFE
16	Vac. pallet back.disc	Non asbestos	Non asbestos	Non asbestos
17	Vac. pallet guide posts	316 SS	316 SS	316 SS
18	Vac. screen	18/8 SS	18/8 SS	18/8 SS
19	Vac. screen retaining ring	Aluminum	Steel	316 SS
20	Pressure screen	18/8 SS	18/8 SS	18/8 SS
21	Sealing washer	Nylon	Nylon	Nylon
22	Spacer disc	Non asbestos	Non asbestos	Non asbestos
23	Sealing washers	G. fiber	G. fiber	G. fiber

DIMENSIONS WEIGHT LOADED VALVES (mm)

Nom. size	A	B	C	D	G
50/2"	50.8	146	81.0	362	202
80/3"	76.2	185	100.0	393	253
100/4"	101.6	213	118.5	421	303
150/6"	152.4	280	142.5	477	392
200/8"	203.2	335	173.0	584	535
250/10"	254.0	397	202.0	639	620
300/12"	304.8	450	235.0	677	682

WEIGHTS WEIGHT/WEIGHT LOADED VALVES (kg)

	2"	3"	4"	6"	8"	10"	12"
*	6	8	12	20	33	50	66
**	12	16	25	42	68	105	138

* Aluminum

** CS/SS

ANDERSON GREENWOOD MARVAC SERIES 121 PRESSURE AND VACUUM RELIEF VALVES

DIMENSIONS AND WEIGHTS

121S SPRING LOADED PRESSURE/WEIGHT LOADED VACUUM

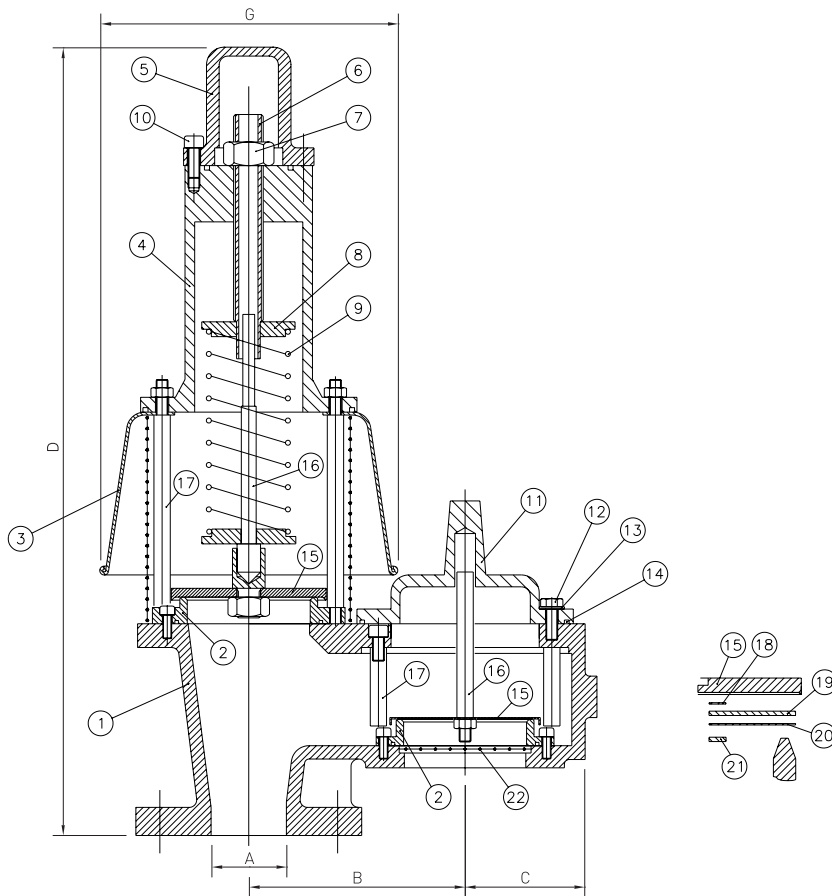

PARTS LIST

Item	Description	Alum spec.	C.steel	SS spec
1	Valve body	Aluminum	WCB	316 SS
2	Removable seat	Aluminum	316 SS	316 SS
3	Weatherhood	Aluminum	C.Steel	316 SS
4	Spring bonnet	Aluminum	WCB	316 SS
5	Bonnet cap	Aluminum	WCB	316 SS
6	Adjustment screw	316 SS	316 SS	316 SS
7	Locknut	18/8 SS	18/8 SS	18/8 SS
8	Spring washers	316 SS	316 SS	316 SS
9	Spring	316 SS	316 SS	316 SS
10	Cap screws	ZP Steel	ZP Steel	18/8 SS
11	Cover	Aluminum	WCB	316 SS
12	Cover screws	ZP Steel	ZP Steel	18/8 SS
13	Sealing washers	G fiber	G fiber	G fiber
14	O-ring seal	Nitrile	Nitrile	Nitrile
15	Pallet	316 SS	316 SS	316 SS
16	Pallet stem	316 SS	316 SS	316 SS
17	Pallet guide posts	316 SS	316 SS	316 SS
18	Spacer disc	Non-asbestos	Non-asbestos	Non-asbestos
19	Diaphragm back.disc	Non-asbestos	Non-asbestos	Non-asbestos
20	Diaphragm	PTFE	PTFE	PTFE
21	Diaphragm supp.disc	316 SS	316 SS	316 SS
22	Screen	Galv St	Galv St	18/8 ST

DIMENSIONS SPRING LOADED VALVES (mm)

Nom. size	A	B	C	D	G
50/2"	50.8	146	81.0	533	202
80/3"	76.2	185	100.0	564	253
100/4"	101.6	213	118.5	591	303
150/6"	152.4	280	142.5	659	392
200/8"	203.2	335	173.0	707	535
250/10"	254.0	397	202.0	810	620
300/12"	304.8	450	235.0	826	682

WEIGHTS SPRING/WEIGHT LOADED VALVES (kg)

	2"	3"	4"	6"	8"	10"	12"
*	8	11	17	28	43	62	80
**	18	24	35	54	83	125	168

* Aluminum

** CS/SS

ANDERSON GREENWOOD MARVAC SERIES 121 PRESSURE AND VACUUM RELIEF VALVES

Max./min. set weight loaded

Min. set pressure 2.5 mbar
 Min. set vacuum 2.5 mbar
 Max. set pressure 70 mbar
 Max. set vacuum 60 mbar

Max./min. set spring loaded

Min. set pressure 70 mbar
 Min. set vacuum 60 mbar
 Max. set pressure 3.5 barg
 Max. set vacuum 800 mbar

121 WEIGHT LOADED PRESSURE FLOW FIGURES

Set pressure mbar	2"			3"			4"			6"			8"			10"			12"		
	20%	35%	50%	20%	35%	50%	20%	35%	50%	20%	35%	50%	20%	35%	50%	20%	35%	50%	20%	35%	50%
2.5	88	112	133	197	252	299	351	448	532	789	1009	1198	1403	1793	2129	2192	2802	3327	3157	4035	4791
10	175	224	266	395	504	599	702	897	1065	1579	2018	2395	2806	3587	4258	4385	5605	6654	6314	8071	9581
25	277	354	421	624	798	947	1109	1418	1683	2496	3190	3787	4437	5671	6733	6933	8862	10520	9983	12761	15149
50	392	501	595	882	1128	1339	1569	2005	2380	3530	4512	5356	6275	8021	9522	9805	12532	14878	14119	18046	21424
60	430	549	652	967	1236	1467	1718	2197	2608	3867	4942	5867	6874	8786	10431	10741	13728	16298	15466	19769	23469

Flow in m³/hr

121 WEIGHT LOADED VACUUM FLOW FIGURES

Set vacuum mbar	2"			3"			4"			6"			8"			10"			12"		
	20%	35%	50%	20%	35%	50%	20%	35%	50%	20%	35%	50%	20%	35%	50%	20%	35%	50%	20%	35%	50%
2.5	44	58	75	99	131	168	175	232	298	395	523	671	702	929	1194	1096	1451	1865	1579	2090	2686
10	88	116	149	197	261	336	351	464	597	789	1045	1343	1403	1858	2387	2192	2903	3730	3157	4180	5371
25	139	184	236	312	413	531	555	734	944	1248	1652	2123	2219	2938	3775	3466	4590	5898	4992	6610	8493
50	196	260	334	441	584	751	784	1039	1335	1765	2337	3003	3138	4154	5338	4902	6491	8341	7059	9347	12011
60	215	284	365	483	640	822	859	1138	1462	1933	2560	3289	3437	4551	5847	5370	7111	9137	7733	10240	13157

Flow in m³/hr

121 SPRING LOADED PRESSURE FLOW FIGURES

Set pressure mbar	2"			3"			4"			6"			8"			10"			12"		
	20%	35%	50%	20%	35%	50%	20%	35%	50%	20%	35%	50%	20%	35%	50%	20%	35%	50%	20%	35%	50%
150	275	376	443	619	847	996	1100	1505	1771	2475	3386	3985	4399	6020	7084	6874	9407	11069	9899	13546	15940
250	355	486	572	800	1094	1288	1422	1946	2290	3199	4378	5151	5687	7783	9158	8886	12161	14310	12796	17511	20606
500	503	688	809	1131	1548	1821	2011	2752	3238	4524	6191	7285	8043	11007	12952	12567	17198	20237	18097	24765	29141
750	615	842	991	1384	1894	2229	2461	3368	3963	5537	7578	8917	9844	13471	15852	15381	21049	24768	22149	30310	35666

Flow in m³/hr

121 SPRING LOADED VACUUM FLOW FIGURES

Set vacuum mbar	2"			3"			4"			6"			8"			10"			12"		
	20%	35%	50%	20%	35%	50%	20%	35%	50%	20%	35%	50%	20%	35%	50%	20%	35%	50%	20%	35%	50%
150	184	251	301	414	565	676	736	1005	1202	1657	2261	2705	2946	4019	4809	4602	6280	7514	6627	9043	10820
250	238	325	389	535	731	874	952	1299	1554	2142	2923	3497	3808	5196	6217	5950	8118	9714	8567	11690	13987
500	337	459	549	757	1033	1236	1346	1837	2198	3029	4133	4945	5385	7348	8792	8414	11481	13737	12116	16532	19781
750	412	562	673	927	1265	1513	1648	2248	2690	3707	5059	6053	6591	8993	10760	10298	14051	16813	14829	20234	24211

Flow in m³/hr