



ANDERSON GREENWOOD DIRECT SPRING OPERATED PRESSURE RELIEF VALVES

SERIES 60 AND 80

Premium performance direct spring operated pressure relief valves that use special internals and soft seats to provide optimum, accurate performance.



Series 80



Series 60

FEATURES

- Soft seat design provides repeatable bubble-tight performance before and after each relief cycle.
- Leak-tight performance near set pressure allows higher operating pressure, resulting in increased process throughput and system optimization.
- Easily replaceable soft seat and seals eliminate expensive, time-consuming lapping of metal components, resulting in lower long-term maintenance costs.
- Externally adjustable blowdown on Types 81/83 allows precise adjustment of reseal pressure without affecting set pressure adjustment. Blowdown can be adjusted with valve in service, helping eliminate the need for costly removal and/or system shut down.
- Types 81/83 provide full lift at set pressure with no overpressure required. Minimizes possibility of freeze-up in applications involving a cryogenic or refrigerant and allows for D.O.T. applications to be set higher than Maximum Allowable Operating Pressure.
- Type 81P spindle design balanced against the effects of back pressure without the use of a bellows, reducing both initial purchase and associated long-term maintenance costs.
- Meet ASME Section VIII and Section XIII (UV Designator) requirements, providing the user with third party verification of valve capacity and performance.
- Comply with the EC Pressure Equipment Directive 2014/68/EU.

GENERAL APPLICATION

Specific valve types are available for gas, vapor, liquid; gas or liquid thermal relief, cryogenic and chemically active applications.

TECHNICAL DATA

Sizes:	1/2" x 3/4" to 2" x 3" (DN 15 to 50)
Orifices:	0.049 to 1.287 in ² (0.316 to 8.303 cm ²)
Connections:	Threaded NPT, flanged
Temperature range:	-423 to + 550°F (-253 to + 288°C)
Set pressures:	20 to 10,000 psig (1.4 to 689.5 barg)
Code:	ASME Section VIII and XIII (UV Designator)

ANDERSON GREENWOOD DIRECT SPRING OPERATED PRESSURE RELIEF VALVES

SERIES 60 AND 80

CONTENTS

Features and benefits.....	1
Selection guide.....	2
Types 81, 83.....	3 - 5
Type 81P.....	6 - 7
Types 63B.....	8
Sizing	
How to size a valve.....	9
Sizing formulas.....	10 - 13
Physical properties.....	14 - 17
Conversion tables.....	18 - 19
Ordering	
How to finalize your selection.....	20
Pressure and temperature ratings.....	21 - 23
Dimensions and weights.....	24 - 58
Materials of construction.....	59 - 63
Capacities.....	64 - 67
Accessories and options.....	68
Additional information.....	69
Model number selection table.....	70

MODELS OVERVIEW

Series 60

Direct spring operated safety valves suitable for medium set pressure gas, vapor and liquid or gas thermal relief applications. Brass construction offers an economical valve for carbon dioxide, natural gas and general gas or vapor services.

Series 80

Direct spring operated safety valves suitable for premium performance. They use special internals and soft seats to provide optimum, accurate performance.

HOW TO SELECT A VALVE

Three steps make it easy to select, size and order the valve.

Step 1: Preliminary valve selection: helps you determine the type of valve that best suits your application.

Step 2: Sizing: provides the information you need to choose the correct valve orifice area.

Step 3: Ordering: explains how to finalize valve selection and order the specific model number, after you have chosen the appropriate valve type and size.

PRELIMINARY SELECTION GUIDE

Valve type	Applications			Seat type	Body material			Set pressure psig (barg)	Relieving temperature °F (°C)	Balanced for back pressure
	Gas/vapor	Liquid	Gas/liquid thermal relief		Brass	CS	SST			
81	X		X	Plastic	X	X	X	50 to 10000 (3.45 to 689.5)	-423 to 500°F (-253 to 260°C)	N
81P		X	X	Plastic	X	X	X	50 to 6000 (3.45 to 413.7)	-423 to 400°F (-253 to 205°C)	Y
83	X		X	O-ring	X	X	X	20 to 2000 (1.40 to 137.9)	-65 to 550°F (-54 to 288°C)	N
63B	X		X	O-ring	X			37 to 531 (2.55 to 36.6)	-65 to 400°F (-54 to 205°C)	N

NOTE

1. Minimum and maximum set pressures may not be available in all orifice sizes (see pages 21-23).

ANDERSON GREENWOOD DIRECT SPRING OPERATED PRESSURE RELIEF VALVES

SERIES 80

PRODUCT OVERVIEW

Types 81, 83 safety valves

The Type 81 direct spring operated safety valve, with an inert plastic seat, is suitable for a wide range of products, pressures and temperatures involving gas, vapor and liquid or gas thermal relief applications. It allows maintained tightness close to set pressure, opens fully at set pressure and provides a safe, external adjustment for short blowdown. The Type 81 valve is best suited for cryogenic, high set pressure and chemically active applications.

The Type 83 direct spring operated safety valve, with an elastomer seat, is ideal for gas processes that operate close to set pressure, for controlling valuable or polluting gas products that should not be lost to the atmosphere and for liquid or gas thermal relief applications. It allows maintained tightness close to set pressure, opens fully at set pressure and provides a safe, external adjustment for short blowdown. The Type 83 is best suited for hard-to-hold gases and vapors and general gas or vapor service.

The huddling chamber of all three valve types has been optimized to provide full opening at set pressure. In addition, there is a unique, independent control of the blowdown via an external adjustment screw. The huddling chamber is powerful enough to generate a lifting force to lift the disk (spindle) fully against the spring force, without any overpressure.

Closing is assisted by the development of a controlled back pressure in the spring chamber. This unique design uses this controlled back pressure in the spring chamber to control precisely the magnitude of blowdown to a reasonable level.

Sizes: 1/2" x 3/4" to 2" x 3" (DN 15 to 50)
Orifices: 0.049 to 1.287 in² (0.316 to 8.303 cm²)
Connections: NPT, Flanged
Temperature range: -423 to + 550°F (-253 to + 288°C)
Set pressures: 20 to 10,000 psig (1.4 to 689.5 barg)
Code: ASME Section VIII and XIII (UV Designator)

SEAT TIGHTNESS PERFORMANCE SPECIFICATIONS

All pressure relief valves are checked for seat leakage per procedures outlined in API 527. The following operating pressures will allow for bubble-tight seat sealing performance.

Valve type	Set pressure range	Operating pressure range
81 and 83	100 psig (6.9 barg) and above	0% to 95% of set
	50 to 99 psig (3.4 to 6.8 barg)	0% to 90% of set
	Below 50 psig (3.4 barg)	0% to 85% of set



ANDERSON GREENWOOD DIRECT SPRING OPERATED PRESSURE RELIEF VALVES

TYPES 81, 83 VALVE OPERATION

VALVE OPERATION

1. System pressure is applied at the inlet to the seat area and exerts a force on the spindle. This upward force is counteracted by the downward force of the spring [Figure 1].
While the system pressure is below set pressure, the pressure in the spring chamber, the inner chamber and the outlet is atmospheric (or uniformly exposed to the current superimposed back pressure, if any) [Figure 2].
2. A secondary orifice, consisting of two or more holes in the guide, permits gas discharge to the spring chamber when the valve opens. This orifice also functions to develop a back pressure in the spring chamber after valve actuation. If the system pressure increases to the point where the total upward force overcomes the spring force, the valve opens [Figure 3].

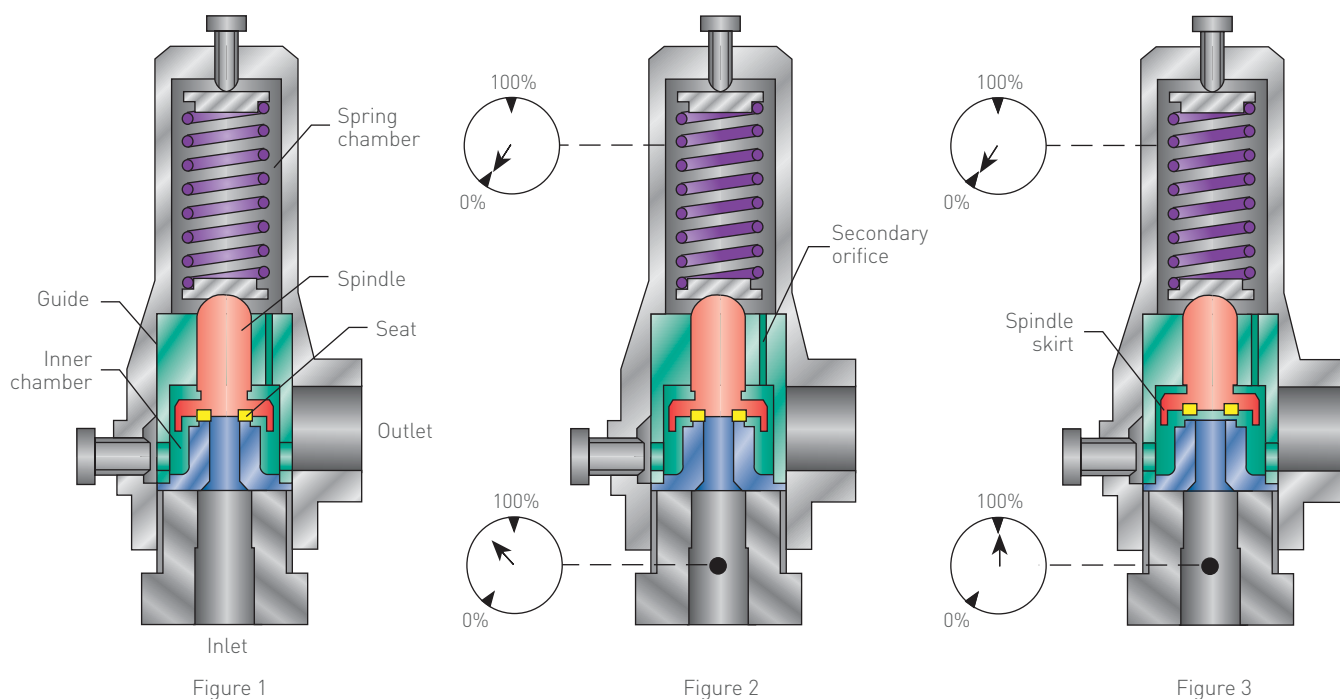

ANDERSON GREENWOOD DIRECT SPRING OPERATED PRESSURE RELIEF VALVES

TYPES 81,83 VALVE OPERATION

3. At set pressure, the initial flow across the seat is exposed to the additional area of the spindle skirt, which generates additional lifting forces. At this opening instant, the pressure in the inner chamber is greater than the pressure in the spring chamber, due to the restricted annular area between the spindle and the guide. This increased force accelerates the spindle rapidly to its full open position (Figure 4).
4. After the spindle has lifted, a developed back pressure will be present in the spring chamber, due to the pressure drop across the secondary orifice. This pressure then acts down against the area of the spindle, as a supplemental force to assist the spring in closing the spindle (Figure 4).
5. This pressure can be adjusted externally with a threaded bolt, which partially restricts one of the guide holes, varying the amount of developed back pressure in the spring chamber (Figure 4) and controlling blowdown, independently of set pressure. Complete restriction of the flow through one of these guide holes by the blowdown adjustment will not affect capacity as the back pressure will never exceed 50% of the inlet pressure (Figure 4).
6. When the inlet (system) pressure drops to a level where the combined spring force and the developed back pressure on the spindle top overcomes the lifting force on the seat area, this causes the spindle to start down. As soon as this happens, the pressure in the inner chamber is reduced instantaneously by a small amount. This increases the unbalance in a downward direction and the spindle accelerates downward, causing the valve to close with a snap action (Figure 5).
7. After valve reseating, residual pressure in the spring chamber immediately dissipates to the valve outlet, back to atmospheric pressure (or the current value of superimposed back pressure) and the valve is returned to its original state (Figure 6).

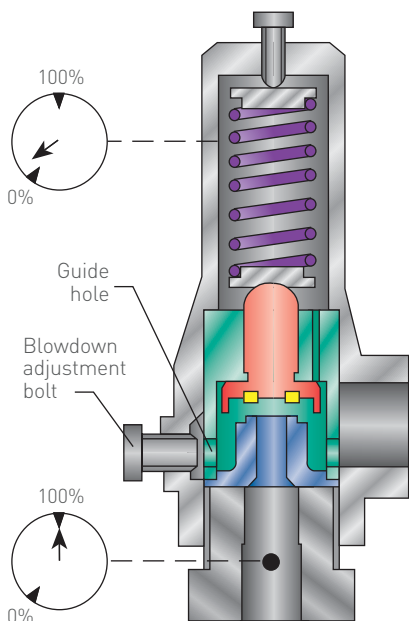

Figure 4

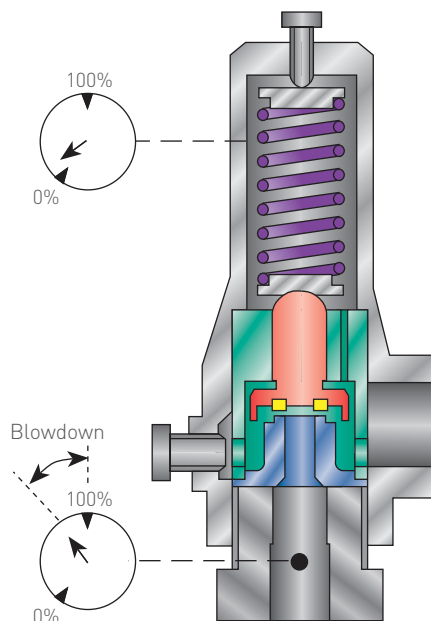

Figure 5

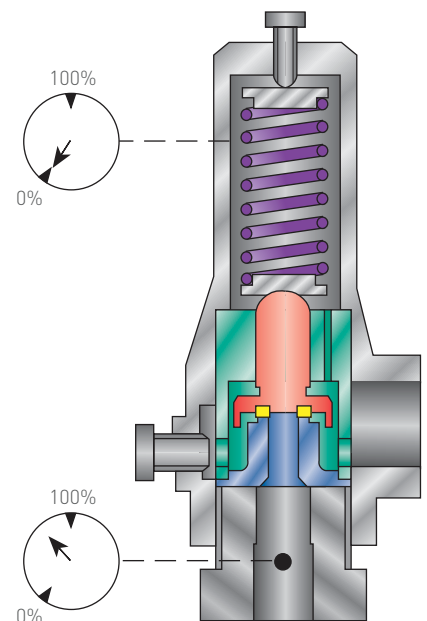

Figure 6

ANDERSON GREENWOOD DIRECT SPRING OPERATED PRESSURE RELIEF VALVES

SERIES 80

TYPE 81P RELIEF VALVE

The Type 81P is a soft-seated, balanced valve with an internal nozzle, guide and spindle assembly which are made especially for the unique demands of liquid service.

Its spindle assembly uses three replaceable sealing members: a specially engineered plastic seat and two elastomer seals. The two seals help balance against back pressure and stabilize against destructive chatter. The nozzle fits closely with the guide, providing perfect alignment for the spindle. Multiple discharge holes in the guide provide free discharge of the relieving flow to the valve outlet.

The spring chamber is isolated by the guide seal and the back pressure (balancing) seal on the stem of the spindle and is vented to the atmosphere enabling the valve to remain fully balanced and operational without the need for an expensive bellows.

The stem of the spindle has a sealing diameter equal to the seat-to-nozzle contact diameter which provides complete balancing against the effects of superimposed back pressure.

The stabilizing ring consists of an O-ring, with a pressure passage that allows system pressure to pass through the seat retainer screw to force the O-ring against the guide, providing a variable resistance to spindle movement, proportional to system pressure. The unpredictable chattering behavior of many liquid safety relief valves is eliminated completely by this pressure-energized stabilizing ring. The possibility of destructive shock waves, which could damage piping and associated pressure-containing members, is reduced substantially.

Sizes: ½" x 1" to 2" x 3" (DN 15 to 50)
Orifices: 0.049 to 1.287 in² (0.316 to 8.303 cm²)
Connections: NPT, Flanged
Temperature range: -423 to + 400°F (-253 to + 205°C)
Set pressures: 50 to 6,000 psig (3.34 to 413.7 barg)
Code: ASME Section VIII and XIII (UV Designator)



SEAT TIGHTNESS PERFORMANCE SPECIFICATIONS

All pressure relief valves are checked for seat leakage per procedures outlined in API 527. The following operating pressures will allow for bubble-tight seat sealing performance.

Set pressure range	Operating pressure range
100 psig (6.9 barg) and above	0% to 92.5% of set
Below 100 psig (6.9 barg)	0% to 80% of set

ANDERSON GREENWOOD DIRECT SPRING OPERATED PRESSURE RELIEF VALVES

TYPE 81P VALVE OPERATION

OPERATION

1. With system pressure below set pressure, the valve will be completely leak-free, through the use of a replaceable soft seat (Figure 1).
2. When the system pressure reaches set pressure, the valve will begin to open with a small steady flow of liquid (Figure 2). The huddling chamber functions to develop full lift by 10% overpressure. Some conventional liquid safety relief valves still require 25% overpressure to achieve full opening and to reach their rated capacity.
3. After initial flow at set pressure, the valve opens smoothly and progressively with system pressure increase, reaching full lift and rated capacity by 10% overpressure (Figure 3).
4. When the full rated capacity is required, the valve will exhibit a blowdown of approximately 20% (Figure 4). When full relieving capacity is not required, the magnitude of blowdown will become progressively smaller. If the system pressure does not significantly rise after reaching set pressure, the valve will reclose at or near the set pressure, similar to the operation of a modulating pilot operated safety relief valve.

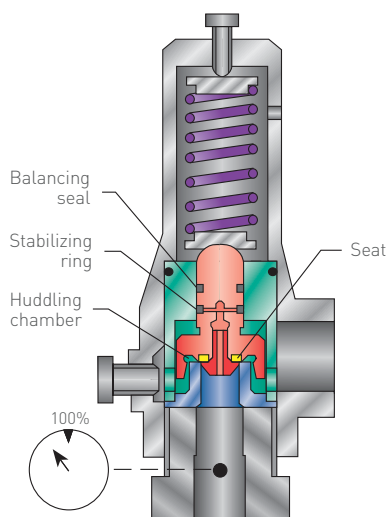

Figure 1

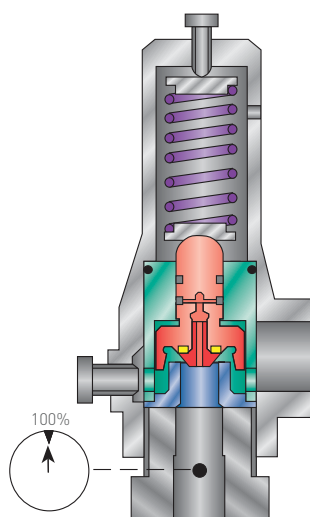

Figure 2

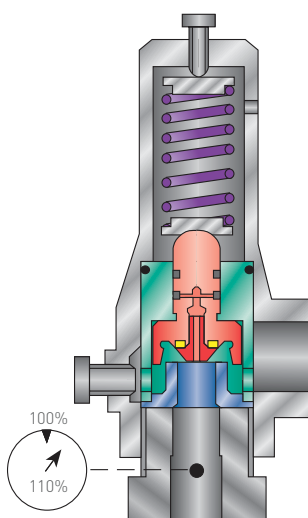

Figure 3

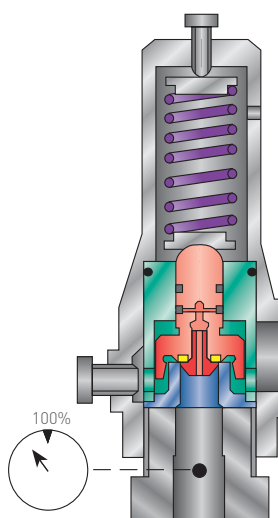

Figure 4

ANDERSON GREENWOOD DIRECT SPRING OPERATED PRESSURE RELIEF VALVES

SERIES 60

TYPES 63B SAFETY VALVES

Type 63B are direct spring operated safety valves suitable for medium set pressure gas, vapor and liquid or gas thermal relief applications. Their brass construction offers an economical valve for carbon dioxide, natural gas and general gas or vapor services.

Sizes:	1/2" x 1" to 3/4" x 1" (DN 15 to 20)
Orifices:	0.077 to 0.150 in ² (0.497 to 0.968 cm ²)
Connections:	NPT
Temperature range:	-65 to + 400°F (-54 to + 205°C)
Set pressures:	30 to 531 psig (2.07 to 36.6 barg)
Code:	ASME Section VIII and XIII (UV Designator)



OPERATION

1. System pressure is applied at the inlet to the seat area and exerts a force on the spindle.
2. This upward force is counteracted by the larger, downward force of the spring which, along with the soft seat, ensures that the valve is bubble-tight.
3. When system pressure increases to the point where the total upward force overcomes the spring force, the valve opens.
4. When the valve set pressure has been reached, the spindle lifts slightly and the system pressure transfers its effect from the seat area to the larger spindle skirt area.
5. This area change, along with the spindle skirt redirecting the flow downwards, generates additional lifting forces and snaps the spindle into full lift by 10% overpressure.
6. When the system pressure drops to a level where the downward spring force can overcome the reduced spindle lifting force, the valve reseats bubble-tight.

SEAT TIGHTNESS PERFORMANCE SPECIFICATIONS

All pressure relief valves are checked for seat leakage per procedures outlined in API 527. The following operating pressures will allow for bubble-tight seat sealing performance.

Valve type	Set pressure range	Operating pressure range
63B	100 psig (6.9 barg) and above	0% to 95% of set
	Below 100 psig (6.9 barg)	0% to 90% of set

ANDERSON GREENWOOD DIRECT SPRING OPERATED PRESSURE RELIEF VALVES

SIZING - SERIES 60 AND 80

HOW TO SIZE A VALVE

Pressure relief valves are selected on the basis of their ability to meet an expected relieving condition and flow a sufficient amount of fluid to prevent excessive pressure increase. This means that the size of the valve orifices must be calculated taking the required flow, lading fluid properties and other factors into consideration.

To select the minimum required orifice area that will flow the required capacity of the system you wish to protect, please refer to the following information, which appears in this section:

1. Sizing formulas.
2. Physical properties of the fluid to be relieved.
3. Conversion tables to aid calculations.
4. Capacities of different orifice areas at different pressures.

Once you have determined the required orifice area for your service conditions, refer to pages 20-49 for selecting and ordering a specific valve model number.

ORIFICE AREAS AND NOZZLE COEFFICIENT

The orifice areas and nozzle coefficients for all Series 60 and 80 valves are tabulated below. These values are derived from the values certified by the National Board of Boiler and Pressure Vessel Inspectors, in accordance with Section VIII, Division 1 and Section XIII (UV Designator) of the ASME Pressure Vessel Code.

VERIFICATION OF SIZING

Orifice area calculations are made and/or verified whenever sufficient data is provided. If no data is furnished, the size selection responsibility will remain totally with the purchaser.

NOZZLE COEFFICIENT AND AVAILABLE ORIFICE SIZES, in² (cm²)

Valve type	K	0.049	0.077	0.110	0.150	0.196	0.307	0.503	0.785	1.287
		(0.316)	(0.497)	(0.710)	(0.968)	(1.265)	(1.981)	(3.245)	(5.065)	(8.303)
		[-4]	[-5]	[-6]	[-7]	[-8 or E]	[F]	[G]	[H]	[J]
81	0.816	X		X		X	X	X	X	X
81P	0.720	X				X		X		X
83	0.816	X		X		X	X	X	X	X
63B	0.835		X							
63B	0.861				X					

ANDERSON GREENWOOD DIRECT SPRING OPERATED PRESSURE RELIEF VALVES

SIZING - SERIES 60 AND 80

ENGLISH SIZING FORMULAS

Vapors or gases (capacity in scfm)^[1]

$$A = \frac{V \sqrt{MTZ}}{6.32 CKP_1}$$

Vapors or gases (capacity in lb/hr)^[1]

$$A = \frac{W \sqrt{TZ}}{CKP_1 \sqrt{M}}$$

V = Required capacity, SCFM

W = Required capacity, lb/hr

V_L = Required capacity, gpm

G = Specific gravity of liquid at flowing temperature referred to water = 1.00 at 70°F [see Physical properties on pages 16-17]

M = Molecular weight of vapor or gas (M = 29 x G, see Physical properties on pages 14-15)

T = Relief temperature, °R (°R = °F + 460)

Z = Compressibility factor (if unknown, assume Z = 1.0)

k = Specific heat ratio k = C_p/C_v

C = Gas constant based on k (if unknown, assume C = 315; see Physical properties on pages 14-15; also see page 13). Gas constant is in USC/SI units per API 520 part 1.

Liquids (capacity in gpm)

$$A = \frac{V_L \sqrt{G}}{38 K K_P K_W K_V \sqrt{P_A - P_B}}$$

K = Nozzle coefficient for 90 percent of actual capacity, derived from National Board Certified Testing (see page 9)

P₁ = Inlet flowing pressure, psia
= Set pressure - inlet pressure loss
+ allowable overpressure + 14.7

P_A = Inlet flowing pressure, psig
= Set pressure - inlet pressure loss
+ allowable overpressure

P_B = Back pressure - psig

K_p = Overpressure correction factor, 1.0

K_w = Back pressure correction factor [see page 13]

K_v = Viscosity correction factor [see page 13]

NOTE

1. As is accepted industry practice, built-up back pressure for conventional (unbalanced) gas valves should not exceed 10 percent.

ANDERSON GREENWOOD DIRECT SPRING OPERATED PRESSURE RELIEF VALVES

SIZING - SERIES 60 AND 80

METRIC SIZING FORMULAS

Vapors or gases (capacity in Nm³/hr)^[1]

$$A = \frac{V \sqrt{MTZ}}{17.02 CKP_1}$$

Vapors or gases (capacity in kg/hr)^[1]

$$A = \frac{1.316 W \sqrt{TZ}}{CKP_1 \sqrt{M}}$$

A = Calculated orifice area, cm²

V = Required capacity, Nm³/hr

W = Required capacity, kg/hr

V_L = Required capacity, M³/hr

G = Specific gravity (relative density) of liquid at flowing temperature referred to water = 1.00 at 20°C (see Physical properties on pages 16-17)

M = Molecular weight of vapor or gas (M = 29 x G, see Physical properties on pages 14-15)

T = Relief temperature, °K (°K = °C + 273)

Z = Compressibility factor (if unknown, assume Z = 1.0)

k = Specific heat ratio k = C_p/C_v

Liquids (capacity in m³/hr)

$$A = \frac{0.19631 V_L \sqrt{G}}{K K_P K_W K_V \sqrt{P_A - P_B}}$$

C = Gas constant based on k (if unknown, assume C = 315; see Physical properties on pages 14-15; also see page 13). Gas constant is in USC/SI units per API 520 part 1.

K = Nozzle coefficient for 90 percent of actual capacity, derived from National Board Certified Testing (see page 9)

P₁ = Inlet flowing pressure, bara = Set pressure - inlet pressure loss + allowable overpressure + 1.013 barg

P_A = Inlet flowing pressure, psig = Set pressure - inlet pressure loss + allowable overpressure

P_B = Back pressure, barg

K_p = Overpressure correction factor, 1.0

K_w = Back pressure correction factor (see page 13)

K_v = Viscosity correction factor (see page 13)

NOTE

1. As is accepted industry practice, built-up back pressure for conventional (unbalanced) gas valves should not exceed 10 percent.

ANDERSON GREENWOOD DIRECT SPRING OPERATED PRESSURE RELIEF VALVES

SIZING - SERIES 60 AND 80

DETERMINING K_v AND K_w

English units

$$R = \frac{V_L (2,800 G)}{\mu \sqrt{A}}$$

or

$$R = \frac{12,700 V_L}{U \sqrt{A}}$$

Metric units

$$R = \frac{31,313 V_L G}{\mu \sqrt{A}}$$

Determining K_v

V_L = Flow rate at the flowing temperature, in U.S. gpm (m^3/hr)

G = Specific gravity of liquid at flowing temperature referred to water = 1.00 at 70°F (21°C)

μ = Absolute viscosity at the flowing temperature, in centipoise

A = Effective discharge area, in square inches (cm^2) (from manufacturer's standard orifice areas)

U = Viscosity at the flowing temperature, in Saybolt Universal seconds

After the value of R is determined, the factor K_v is obtained from the graph. Factor K_v is applied to correct the 'preliminary required discharge area'. If the corrected area exceeds the 'chosen standard orifice area', the calculations should be repeated using the next larger standard orifice size.

Determining K_w

See graph at right.

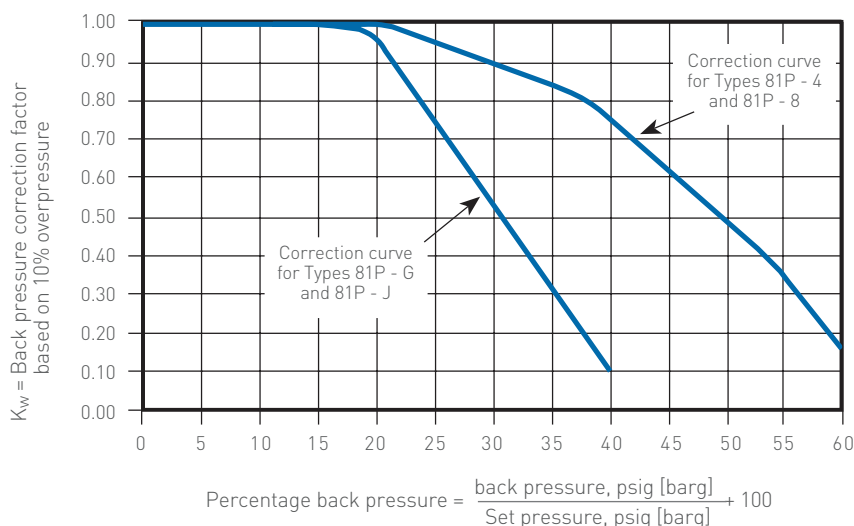
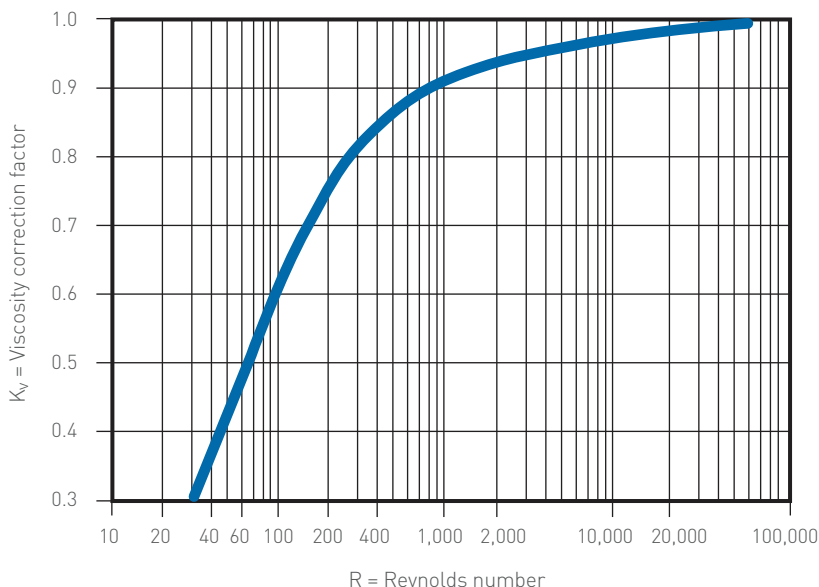

$$\text{Percentage back pressure} = \frac{\text{back pressure, psig [barg]}}{\text{Set pressure, psig [barg]}} + 100$$

ANDERSON GREENWOOD DIRECT SPRING OPERATED PRESSURE RELIEF VALVES

SIZING - SERIES 60 AND 80

DETERMINING C, BASED ON k - GAS CONSTANT, C

k	C	k	C
1.00	315	1.52	366
1.02	318	1.54	368
1.04	320	1.56	369
1.06	322	1.58	371
1.08	324	1.60	372
1.10	327	1.62	374
1.12	329	1.64	376
1.14	331	1.66	377
1.16	333	1.68	379
1.18	335	1.70	380
1.20	337	1.72	382
1.22	339	1.74	383
1.24	341	1.76	384
1.26	343	1.78	386
1.28	345	1.80	387
1.30	347	1.82	388
1.32	349	1.84	390
1.34	351	1.86	391
1.36	352	1.88	392
1.38	354	1.90	394
1.40	356	1.92	395
1.42	358	1.94	397
1.44	359	1.96	398
1.46	361	1.98	399
1.48	363	2.00	400
1.50	364	2.02	401

ANDERSON GREENWOOD DIRECT SPRING OPERATED PRESSURE RELIEF VALVES

SIZING - SERIES 60 AND 80

PHYSICAL PROPERTIES

Gas or vapor	M Molecular weight	k Specific heat ratio	C Gas constant
Acetone	58.08	1.12	329
Acetylene (ethyne)	26.04	1.26	343
Air	28.97	1.40	356
Ammonia, anhydrous	17.03	1.31	348
Argon	39.95	1.67	378
Benzene (benzol or benzole)	78.11	1.12	329
Boron trifluoride	67.82	1.20	337
Butadiene-1, 3 (divinyl)	54.09	1.12	329
Butane-n (normal butane)	58.12	1.09	326
Butylene (1-butene)	56.11	1.11	328
Carbon dioxide	44.01	1.29	346
Carbon disulfide (C. bisulfide)	76.13	1.21	338
Carbon monoxide	28.01	1.40	356
Carbon tetrachloride	153.82	1.11	328
Chlorine	70.91	1.36	353
Chloromethane (methyl chloride)	50.49	1.28	345
Cyclohexane	84.16	1.09	326
Cyclopropane (trimethylene)	42.08	1.11	328
Decane-n	142.29	1.04	320
Diethylene glycol (DEG)	106.17	1.07	323
Dimethyl ether (methyl ether)	46.07	1.11	328
Dowtherm A	165.00	1.05	321
Dowtherm E	147.00	1.00	315
Ethane	30.07	1.19	336
Ethyl alcohol (ethanol)	46.07	1.13	330
Ethylene (ethene)	28.05	1.24	341
Ethylene glycol	62.07	1.09	326
Ethylene oxide	44.05	1.21	338
Fluorocarbons:			
12, dichlorodifluoromethane	120.93	1.14	331
13, chlorotrifluoromethane	104.47	1.17	334
13B1, bromotrifluoromethane	148.93	1.14	331
22, chlorodifluoromethane	86.48	1.18	335
115, chloropentafluoroethane	154.48	1.08	324
Glycerine (glycerin or glycerol)	92.10	1.06	322
Helium	4.00	1.67	378
Heptane	100.21	1.05	321

ANDERSON GREENWOOD DIRECT SPRING OPERATED PRESSURE RELIEF VALVES

SIZING - SERIES 60 AND 80

PHYSICAL PROPERTIES

Gas or vapor	M Molecular weight	k Specific heat ratio	C Gas constant
Hexane	86.18	1.06	322
Hydrogen	2.02	1.41	357
Hydrogen chloride, anhydrous	36.46	1.41	357
Hydrogen sulfide	34.08	1.32	349
Isobutane (2-methylpropane)	58.12	1.10	327
Isoprene (2-methyl-1, 3 butadiene)	68.12	1.09	326
Isopropyl alcohol (isopropanol)	60.10	1.09	326
Krypton	83.80	1.71	380
Methane	16.04	1.31	348
Methyl alcohol (methanol)	32.04	1.20	337
Methylamines, anhydrous			
Monomethylamine (methylamine)	31.06	1.02	317
Dimethylamine	45.08	1.15	332
Trimethylamine	59.11	1.18	335
Methyl mercaptan (methanethiol)	48.11	1.20	337
Napthalene (napthaline)	128.17	1.07	323
Natural gas (specific gravity = 0.60)	17.40	1.27	344
Neon	20.18	1.64	375
Nitrogen	28.01	1.40	356
Nitrous oxide	44.01	1.30	347
Octane	114.23	1.05	321
Oxygen	32.00	1.40	356
Pentane	72.15	1.07	323
Propadiene (allene)	40.07	1.69	379
Propane	44.10	1.13	330
Propylene (propene)	42.08	1.15	332
Propylene oxide	58.08	1.13	330
Styrene	104.15	1.07	323
Sulfur dioxide	64.06	1.28	345
Sulfur hexafluoride	146.05	1.09	326
Toluene (toluol or methylbenzene)	92.14	1.09	326
Triethylene glycol (TEG)	150.18	1.04	320
Vinyl chloride monomer (VCM)	62.50	1.19	336
Xenon	131.30	1.65	376
Xylene (p-xylene)	106.17	1.07	323

ANDERSON GREENWOOD DIRECT SPRING OPERATED PRESSURE RELIEF VALVES

SIZING - SERIES 60 AND 80

PHYSICAL PROPERTIES

Liquid	G		
	Specific gravity Water = 1	°F	[°C]
Acetaldehyde	0.779	68	20
Acetic acid	1.051	68	20
Acetone	0.792	68	20
Ammonia, anhydrous	0.666	68	20
Automotive crankcase and gear oils:			
SAE-5W through SAE 150	0.88-0.94	60	15.6
Beer	1.01	60	15.6
Benzene (benzol)	0.880	68	20
Boron trifluoride	1.57	-148	-100
Butadiene - 1, 3	0.622	68	20
Butane-n (normal butane)	0.579	68	20
Butylene (1-butene)	0.600	68	20
Carbon dioxide	1.03	-4	-20
Carbon disulfide (C. bisulfide)	1.27	68	20
Carbon tetrachloride	1.60	68	20
Chlorine	1.42	68	20
Chloromethane (methyl chloride)	0.921	68	20
Crude oils:			
32.6 deg API	0.862	60	15.6
35.6 deg API	0.847	60	15.6
40 deg API	0.825	60	15.6
48 deg API	0.79	60	15.6
Cyclohexane	0.780	68	20
Cyclopropane (trimethylene)	0.621	68	20
Decane-n	0.731	68	20
Diesel fuel oils	0.82-0.95	60	15.6
Diethylene glycol (DEG)	1.12	68	20
Dimethyl ether (methyl ether)	0.663	68	20
Dowtherm A	0.998	68	20
Dowtherm E	1.087	68	20
Ethane	0.336	68	20
Ethyl alcohol (ethanol)	0.79	68	20
Ethylene (ethene)	0.569	-155	-104
Ethylene glycol	1.115	68	20
Ethylene oxide	0.901	68	20

ANDERSON GREENWOOD DIRECT SPRING OPERATED PRESSURE RELIEF VALVES

SIZING - SERIES 60 AND 80

PHYSICAL PROPERTIES

Liquid	G		
	Specific gravity Water = 1	°F	[°C]
Fluorocarbons:			
R12, dichlorodifluoromethane	1.34	68	20
R13, chlorotrifluoromethane	0.916	68	20
R13B1, bromotrifluoromethane	1.58	68	20
R22, chlorodifluoromethane	1.21	68	20
R115, chloropentafluoromethane	1.31	68	20
Fuel oils, nos. 1, 2, 3, 5 and 6	0.82-0.95	60	15.6
Gasolines	0.68-0.74	60	15.6
Glycerine (glycerin or glycerol)	1.26	68	20
Heptane	0.685	68	20
Hexane	0.660	68	20
Hydrochloric acid	1.64	60	15.6
Hydrogen sulfide	0.78	68	20
Isobutane (2-methylpropane)	0.558	68	20
Isoprene (2-methyl - 1, 3-butadiene)	0.682	68	20
Isopropyl alcohol (isopropanol)	0.786	68	20
Jet fuel (average)	0.82	60	15.6
Kerosene	0.78-0.82	60	15.6
Methyl alcohol (methanol)	0.792	68	20
Methylamines, anhydrous:			
Monomethylamine (methylamine)	0.663	68	20
Dimethylamine	0.656	68	20
Trimethylamine	0.634	68	20
Methyl mercaptan (methanethiol)	0.870	68	20
Nitric acid	1.50	60	15.6
Nitrous oxide	1.23	-127	-88.5
Octane	0.703	68	20
Pentane	0.627	68	20
Propadiene (allene)	0.659	-30	-34.4
Propane	0.501	68	20
Propylene (propene)	0.514	68	20
Propylene oxide	0.830	68	20
Styrene	0.908	68	20
Sulfur dioxide	1.43	68	20
Sulfur hexafluoride	1.37	68	20
Sulfuric acid:			
95-100%	1.839	68	20
60%	1.50	68	20
20%	1.14	68	20
Toluene (toluol or methylbenzene)	0.868	68	20
Triethylene glycol (TEG)	1.126	68	20
Vinyl chloride monomer (VCM)	0.985	-4	-20
Water, fresh	1.00	68	20
Water, sea	1.03	68	20
Xylene (p-xylene)	0.862	68	20

ANDERSON GREENWOOD DIRECT SPRING OPERATED PRESSURE RELIEF VALVES

SIZING - SERIES 60 AND 80

GAS FLOW CONVERSIONS

GAS FLOW CONVERSIONS

Given	To find desired value, multiply 'Given' value by factor below					
	SCFM	SCFH	lb/hr	(kg/hr)	(Nm ³ /hr)	(Nm ³ /min)
scfm ²	----	60	M	M	1.608	0.0268
scfh ²	0.01677	----	M	M	0.0268	0.000447
lb/hr ³ or #/hr ³	$\frac{6.32}{M}$	$\frac{379.2}{M}$	----	0.4536	$\frac{10.17}{M}$	$\frac{0.1695}{M}$
kg/hr ⁴	$\frac{13.93}{M}$	$\frac{836.1}{M}$	2.205	----	$\frac{22.40}{M}$	$\frac{0.3733}{M}$
Nm ³ /hr ⁵	0.6216	37.30	M	M	----	0.01667
Nm ³ /min ⁵	37.30	2238	5.901 M	2.676 M	60	----

If flow is expressed in actual volume, such as cfm (cubic feet per minute) or acfm (actual cfm) as is often done for compressors, where the flow is described as displacement or swept volume, the flow may be converted to scfm as follows (or from flow expressed in m³/hr to Nm³/hr).

Inch-pound units

$$SCFM \left(\begin{matrix} cfm \\ or \\ acfm \end{matrix} \right) \times \frac{14.7 + p}{14.7} \times \frac{520}{460 + t}$$

Where:

p = gauge pressure of gas or vapor in psig
t = temperature of gas or vapor in °F

Metric units

$$\frac{Nm^3}{hr} = n^3 hr = x \frac{1.013 + p}{1.013} \times \frac{273}{273 + t}$$

Where:

p = gauge pressure of gas or vapor in barg
t = temperature of gas or vapor in °C

NOTES

1. M = molecular weight of vapor or gas.
2. Volumetric flow (per time unit of hour or minute as shown) in standard cubic feet per minute at 14.7 psia (1.013 bara), 60°F (16°C).
3. Weight flow in pounds per hour.
4. Weight flow in kilograms per hour.
5. Volumetric flow (per time unit of hour or minute as shown) at 1.013 bara 32°F (0°C). This represents the commercial standard, known as the Normal Temperature and Pressure (NTP).
Conversions from one volumetric flow rate to another or to weight flow (and vice versa) may only be done when the volumetric flow is expressed in the standard conditions shown above. If flows are expressed at temperature or pressure bases that differ from those listed above, they must first be converted to the standard base.

PRESSURE CONVERSION

PRESSURE CONVERSION

Given	To find desired value, multiply 'Given' value by factor below			
	kPa	psig	kg/cm ²	barg
kPa [kilopascal]	----	0.1450	0.0102	0.01000
psig (pounds/in ²)	6.895	----	0.0703	0.06895
kg/cm ² (kilograms/cm ²)	98.07	14.22	----	0.98070
barg	100.00	14.50	1.020	----

AREA CONVERSION

Given	To find desired value, multiply 'Given' value by factor below			
	in ²	ft ²	mm ²	cm ²
in ²	----	0.006944	645.16	6.4516
cm ²	0.155	1.076 x 10 ⁻³	100	----
ft ²	144	----	92900	929
mm ²	0.00155	1.076 x 10 ⁻⁵	----	0.01

NOTE

1. Normal Temperature and Pressure (NTP) Conditions are, at sea level, equal to 1.013 bara or 1.033 kg/cm² (kilograms force per square centimeter absolute) at a base temperature of 32°F (0°C). This differs slightly from Metric Standard Conditions (MSC), which uses 1.013 bara 60°F (15°C) for the base temperature.

ANDERSON GREENWOOD DIRECT SPRING OPERATED PRESSURE RELIEF VALVES

SIZING - SERIES 60 AND 80

CONVERSION FACTORS

ABSOLUTE VISCOSITY

Given	To find desired value, multiply 'Given' value by factor below			
	poise	Centipoise	gm/cm-sec	lb/ft-sec
poise	----	100	1.00	0.067200
centipoise	0.01	----	0.01	0.000672
gm/cm-sec	1	100	----	0.067200
lb/ft-sec	14.88	1488	14.88	----

KINEMATIC VISCOSITY

Given	To find desired value, multiply 'Given' value by factor below			
	stoke	Centistoke	cm ² /sec	ft ² /sec
stoke	----	100	1	0.001076
centistoke	0.01	----	0.01	1.076 x 10 ⁻⁵
cm ² /sec	1	100	----	0.001076
ft ² /sec	929.0	92900	929.0	----

NOTES

1. Kinematic viscosity x specific gravity = absolute viscosity.
2. Centistokes x specific gravity = centipoise.
3. Saybolt Second Universal (SSU) x 0.216 x specific gravity = centipoise.

LIQUID FLOW CONVERSIONS

Given	To find desired value, multiply 'Given' value by factor below				
	l/hr	gpm - US	gpm - Imp	barrels/day	m ³ /hr
l/hr (litres/hour)	----	0.00440	0.003666	0.1510	0.0010
gpm (US gallons per minute)	227.1	----	0.8327	34.29	0.2271
gpm (Imperial gallons per minute)	272.8	1.201	----	41.18	0.2728
barrels/day (petroleum - 42 US gallons)	6.624	0.02917	0.02429	----	0.006624
m ³ /hr (cubic meters per hour)	1000	4.403	3.666	151.0	----
m ³ /s (cubic meters per seconds)	3.6 x 10 ⁶	0.02917	0.02429	----	0.006624
kg/hr (kilograms per hour)	1/G	1/227.1G	1/272.8G	0.151/G	1/1000G
lb/hr (pounds per hour)	1/2.205G	1/500.8G	1/601.5G	1/14.61G	1/2205G

NOTE

1. G = Specific gravity of liquid at its relieving temperature compared to that of water at 68°F [20°C], where G_{water} = 1.00.

ANDERSON GREENWOOD DIRECT SPRING OPERATED PRESSURE RELIEF VALVES

ORDERING - SERIES 60 AND 80

ORDERING – HOW TO FINALIZE VALVE SELECTION

Once you have determined the basic type (e.g., 81, 83, etc.) of valve required in Step 1 and determined your required orifice area in Step 2, please refer to the following information to finalize the selection and specification and then order the pressure relief valve best suited for your application.

PRESSURE AND TEMPERATURE RATING

Compare your preliminary selected valve type and orifice with the following pressure and temperature rating tables on pages 21-23. This will ensure the valve type and orifice meets the process requirements.

VALVE MATERIAL

You can select the proper body material and soft goods by using the pressure and temperature rating tables. Keep in mind that proper selection of soft goods also includes chemical compatibility with the process.

INLET AND OUTLET - SIZE AND TYPE

Please refer to the dimensions and weight tables on pages 24-35 for proper size and type.

BILL OF MATERIAL

Detailed bills of materials are included on pages 36 to 40 to assist in finalizing material selection and selecting the model number.

ANDERSON GREENWOOD DIRECT SPRING OPERATED PRESSURE RELIEF VALVES

PRESSURE AND TEMPERATURE RATINGS - SERIES 80

PRESSURE AND TEMPERATURE RATINGS FOR ORIFICE SIZES -4 TO -8

Valve model type	Seat material	Temperature range ^[2]	Set pressure range ^{[3][4]} , psig (barg)					
			-4 Brass	-4 CS and SS	-6 (D) Brass	-6 (D) CS and SS	-8 (E) Brass	-8 (E) CS and SS
83	NBR	-65 to 275°F (-54 to 135°C)	20 to 2000 (1.4 to 137.9)	20 to 2000 (1.4 to 137.9)	20 to 2000 (1.4 to 137.9)	20 to 2000 (1.4 to 137.9)	20 to 2000 (1.4 to 137.9)	20 to 2000 (1.4 to 137.9)
83	FKM	-15 to 400°F (-26 to 204°C)	20 to 2000 (1.4 to 137.9)	20 to 2000 (1.4 to 137.9)	20 to 2000 (1.4 to 137.9)	20 to 2000 (1.4 to 137.9)	20 to 2000 (1.4 to 137.9)	20 to 2000 (1.4 to 137.9)
83	EPR	-65 to 300°F (-54 to 149°C)	20 to 2000 (1.4 to 137.9)	20 to 2000 (1.4 to 137.9)	20 to 2000 (1.4 to 137.9)	20 to 2000 (1.4 to 137.9)	20 to 2000 (1.4 to 137.9)	20 to 2000 (1.4 to 137.9)
83	Perfluoroelastomers (FFKM)	-0 to 550°F (-18 to 288°C)	20 to 2000 (1.4 to 137.9)	20 to 2000 (1.4 to 137.9)	20 to 2000 (1.4 to 137.9)	20 to 2000 (1.4 to 137.9)	20 to 2000 (1.4 to 137.9)	20 to 2000 (1.4 to 137.9)
81	PTFE	-423 to 400°F (-256 to 204°C)	50 to 1000 (6.9 to 69.0)	50 to 1000 (6.9 to 69.0)	50 to 900 (6.9 to 62.1)	50 to 900 (6.9 to 62.1)	50 to 900 (6.9 to 62.1)	50 to 900 (6.9 to 62.1)
81	PCTFE	-423 to 300°F (-256 to 149°C)	1001 to 4000 (69.1 to 275.8)	1001 to 4000 (69.1 to 275.8)	901 to 1500 (62.2 to 103.4)	901 to 1500 (62.2 to 103.4)	901 to 1500 (62.2 to 103.4)	901 to 1500 (62.2 to 103.4)
81	Vespel	-423 to 500°F (-256 to 260°C)	---- ----	4001 to 10,000 (276.1 to 689.5)	1,501 to 4740 (103.5 to 326.8)	1501 to 9600 (103.5 to 661.9)	1501 to 4000 (103.5 to 275.8)	1501 to 6000 (103.5 to 413.7)
81P	PTFE ^[1]	-423 to 400°F ^[5] (-253 to 204°C)	50 to 2000 (3.4 to 137.9)	50 to 2000 (3.4 to 137.9)	---- ----	---- ----	50 to 2000 (3.4 to 137.9)	50 to 2000 (3.4 to 137.9)
81P	PCTFE ^[1]	-423 to 300°F ^[5] (-253 to 149°C)	2001 to 4000 (138.1 to 275.8)	2001 to 6000 (138.1 to 413.7)	---- ----	---- ----	2,001 to 4000 (138.1 to 275.8)	2001 to 4000 (138.1 to 275.8)

NOTES

- Minimum temperature is based on elastomer spindle and guide seals.
- Temperature range is limited according to body material of construction as follows:
 Brass: -325 to 406°F
 (-198 to 208°C)
 CS: -20 to 550°F
 (-29 to 288°C)
 SS: -423 to 550°F
 (-253 to 288°C).
- Maximum set pressure limited for NACE option as follows:
 Type 81-6: 7100 psig maximum
 Type 81-8: 3120 psig maximum
- Set pressure range for -8(E) orifice as follows:
 -8: Set pressure up to 4000 psig (276 barg)
 (Types 81 and 81P)
 -E: Set pressure over 4000 psig (276 barg)
 (Types 81 and 81P)
- The Type 81P-4 and Type 81P-8 are capable of functioning within a cryogenic temperature range spanning from -423°F (-256°C) to -65°F (-54°C) while offering a maximum set pressure range of 2000 psig (137.9 barg). Consult factory for set pressures above 2001 psig (138 barg).

ANDERSON GREENWOOD DIRECT SPRING OPERATED PRESSURE RELIEF VALVES

PRESSURE AND TEMPERATURE RATINGS - SERIES 80

PRESSURE AND TEMPERATURE RATINGS FOR ORIFICE SIZES F TO J

Valve model type	Seat material	Temperature range ^[2]	Brass - set pressure range, psig (barg)			
			F	G	H	J
83	NBR	-65 to 275°F (-54 to 135°C)	20 to 2000 (1.4 to 137.9)	20 to 2000 (1.4 to 137.9)	20 to 2000 (1.4 to 137.9)	20 to 1620 (1.4 to 111.7)
83	FKM	-15 to 400°F (-26 to 205°C)	20 to 2000 (1.4 to 137.9)	20 to 2000 (1.4 to 137.9)	20 to 2000 (1.4 to 137.9)	20 to 1620 (1.4 to 111.7)
83	EPR	-65 to 300°F (-54 to 149°C)	20 to 2000 (1.4 to 137.9)	20 to 2000 (1.4 to 137.9)	20 to 2000 (1.4 to 137.9)	20 to 1620 (1.4 to 111.7)
83	FFKM	-0 to 550°F (-18 to 288°C)	20 to 2000 (1.4 to 137.9)	20 to 2000 (1.4 to 137.9)	20 to 2000 (1.4 to 137.9)	20 to 1620 (1.4 to 111.7)
81	PTFE	-423 to 400°F (-253 to 205°C)	50 to 500 (3.5 to 34.5)	50 to 500 (3.5 to 34.5)	50 to 500 (3.5 to 34.5)	50 to 500 (3.5 to 34.5)
81	PCTFE	-423 to 300°F (-253 to 149°C)	501 to 750 (34.5 to 51.7)	501 to 750 (34.5 to 51.7)	501 to 750 (34.5 to 51.7)	501 to 750 (34.5 to 51.7)
81	Vespel	-423 to 500°F (-253 to 260°C)	751 to 2990 (51.8 to 206.2)	751 to 2570 (51.8 to 177.2)	751 to 2270 (51.8 to 156.5)	751 to 1620 (51.8 to 111.7)
81P	PTFE ^[1]	-65 to 400°F (-54 to 205°C)	----	50 to 1000 (3.5 to 69.0)	----	50 to 1000 (3.5 to 69.0)
81P	PCTFE ^[1]	-65 to 300°F (-54 to 149°C)	----	1001 to 2570 (69.0 to 177.2)	----	1001 to 1620 (69.0 to 111.7)

NOTES

1. Minimum temperature is based on elastomer spindle seals.
2. Temperature range is limited according to body material of construction as follows:
 - Brass: -325 to 406°F
(-198 to 208°C)
 - CS: -20 to 550°F
(-29 to 288°C)
 - SS: -423 to 550°F
(-253 to 288°C).

ANDERSON GREENWOOD DIRECT SPRING OPERATED PRESSURE RELIEF VALVES

PRESSURE AND TEMPERATURE RATINGS - SERIES 60 AND 80

PRESSURE AND TEMPERATURE RATINGS FOR ORIFICE SIZES F TO J

Valve model type	Seat material	Temperature range ^[2]	CS and SS - set pressure range, psig (barg)			
			F	G	H	J
83	NBR	-65 to 275°F (-54 to 135°C)	20 to 2000 (1.4 to 137.9)	20 to 2000 (1.4 to 137.9)	20 to 2000 (1.4 to 137.9)	20 to 1620 (1.4 to 111.7)
83	FKM	-15 to 400°F (-26 to 205°C)	20 to 2000 (1.4 to 137.9)	20 to 2000 (1.4 to 137.9)	20 to 2000 (1.4 to 137.9)	20 to 1620 (1.4 to 111.7)
83	EPR	-65 to 300°F (-54 to 149°C)	20 to 2000 (1.4 to 137.9)	20 to 2000 (1.4 to 137.9)	20 to 2000 (1.4 to 137.9)	20 to 1620 (1.4 to 111.7)
83	FFKM	0 to 550°F (-18 to 288°C)	20 to 2000 (1.4 to 137.9)	20 to 2000 (1.4 to 137.9)	20 to 2000 (1.4 to 137.9)	20 to 1620 (1.4 to 111.7)
81	PTFE	-423 to 400°F (-253 to 205°C)	50 to 500 (3.5 to 34.5)	50 to 500 (3.5 to 34.5)	50 to 500 (3.5 to 34.5)	50 to 500 (3.5 to 34.5)
81	PCTFE	-423 to 300°F (-253 to 149°C)	501 to 750 (34.5 to 51.7)	501 to 750 (34.5 to 51.7)	501 to 750 (34.5 to 51.7)	501 to 750 (34.5 to 51.7)
81	Vespel	-423 to 500°F (-253 to 260°C)	751 to 4,040 (51.8 to 278.6)	751 to 2570 (51.8 to 177.2)	751 to 2580 (51.8 to 177.9)	751 to 1620 (51.8 to 111.7)
81P	PTFE ^[1]	-65 to 400°F (-54 to 205°C)	----	50 to 1000 (3.5 to 69.0)	----	50 to 1000 (3.5 to 69.0)
81P	PCTFE ^[1]	-65 to 300°F (-54 to 149°C)	----	1001 to 6000 (69.0 to 413.7)	----	1001 to 1620 (69.0 to 111.7)

NOTES

- Minimum temperature is based on elastomer spindle seals.
- Temperature range is limited according to body material of construction as follows:
 Brass: -325 to 406°F
 (-198 to 208°C)
 CS: -20 to 550°F
 (-29 to 288°C)
 SS: -423 to 550°F
 (-253 to 288°C).

PRESSURE AND TEMPERATURE RATINGS

Valve model type	Seat material	Temperature range	Set pressure range, psig (barg)	
			-5	-7
63B	NBR	-65 to 275°F (-54 to 135°C)	37 to 531 (2.6 to 36.6)	45 to 374 (3.1 to 25.9)
63B	FKM	-15 to 400°F (-26 to 205°C)	37 to 531 (2.6 to 36.6)	45 to 374 (3.1 to 25.9)
63B	EPR	-65 to 300°F (-54 to 149°C)	37 to 531 (2.6 to 36.6)	45 to 374 (3.1 to 25.9)

ANDERSON GREENWOOD DIRECT SPRING OPERATED PRESSURE RELIEF VALVES

DIMENSIONS AND WEIGHTS - SERIES 80

THREADED CONNECTIONS

DIMENSIONS AND WEIGHTS FOR -4 ORIFICE

Valve model type	Body material	Set pressure range	Valve connections		Threaded connections		Dimensions			Approx. weight lb (kg)
			Inlet	Outlet	Inlet	Outlet	A	B	C max ^[2]	
			in (DN)	in (DN)			in (mm)	in (mm)	in (mm)	
81, 83	Brass,	20 to 4000 psig (1.4 to 276 barg) ^[1]	1/2 (15)	3/4 and 1 (20 and 25)	FNPT	FNPT	2.90 (74)	1.50 (38)	9.55 (243)	4.3 (2.0)
			1/2 (15)	3/4 and 1 (20 and 25)	MNPT	FNPT	2.90 (74)	1.50 (38)	9.55 (243)	4.3 (2.0)
	3/4 (20)	3/4 and 1 (20 and 25)	FNPT	FNPT	3.07 (78)	1.50 (38)	9.72 (247)	4.3 (2.0)		
	3/4 (20)	3/4 and 1 (20 and 25)	MNPT	FNPT	2.90 (74)	1.50 (38)	9.55 (243)	4.3 (2.0)		
	1 (25)	1 (25)	MNPT	FNPT	3.07 (78)	1.50 (38)	9.72 (247)	4.3 (2.0)		
81	CS, SS	4001 to 10.000 psig (276.1 to 690 barg)	3/4 and 1 (20 and 25)	1 (25)	FNPT	FNPT	3.70 (94)	1.81 (46)	14.10 (358)	13.3 (6.1)
			3/4 and 1 (20 and 25)	1 (25)	MNPT	FNPT	3.80 (97)	1.81 (46)	14.20 (361)	13.3 (6.1)
81P	Brass,	50 to 1.160 psig (3.4 to 80 barg)	1/2 (15)	1 (25)	FNPT	FNPT	3.80 (97)	1.81 (46)	10.95 (278)	8.3 (3.8)
			1/2 (15)	1 (25)	MNPT	FNPT	3.80 (97)	1.81 (46)	10.95 (278)	8.3 (3.8)
	3/4 and 1 (20 and 25)	1 (25)	FNPT	FNPT	3.70 (94)	1.81 (46)	10.87 (276)	8.3 (3.8)		
	3/4 and 1 (20 and 25)	1 (25)	MNPT	FNPT	3.80 (97)	1.81 (46)	10.95 (278)	8.3 (3.8)		
81P	Brass ^[3] ,	1161 to 6000 psig (80.1 to 414 barg)	1/2 (15)	1 (25)	FNPT	FNPT	3.80 (97)	1.81 (46)	14.20 (360.7)	13.8 (6.3)
			1/2 (15)	1 (25)	MNPT	FNPT	3.80 (97)	1.81 (46)	14.20 (360.7)	13.8 (6.3)
	CS ^[4] , SS4	3/4 and 1 (20 and 25)	1 (25)	FNPT	FNPT	3.70 (94)	1.81 (46)	14.10 (358.1)	13.8 (6.3)	
		3/4 and 1 (20 and 25)	1 (25)	MNPT	FNPT	3.80 (97)	1.81 (46)	14.20 (360.7)	13.8 (6.3)	

NOTES

- Normal set pressure range for Type 81: 100 to 4000 psig (6.9 to 275.8 barg) and Type 83: 20 to 2000 psig (1.4 to 137.9 barg).
- Add 0.90" (23 mm) to 'C max.' dimension for numbered orifice Type 81, 83 and 81P with packed lift lever option.
- For MNPT brass body: 2120 psig max. can be set without thrust load bracing and for set pressure between 2121-2800 psig, warning tag 05.2358.001 must be supplied.
- For MNPT CS and SS body: 4000 psig max. can be set without thrust load bracing and for set pressures between 4001-5000 psig, warning tag 05.2358.001 must be supplied.

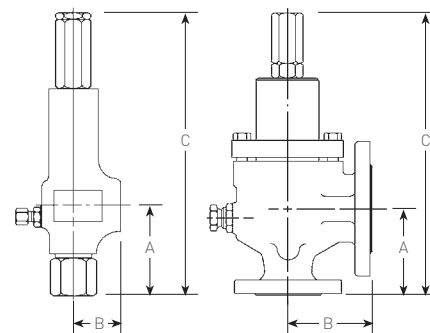

ANDERSON GREENWOOD DIRECT SPRING OPERATED PRESSURE RELIEF VALVES

DIMENSIONS AND WEIGHTS - SERIES 80

DIMENSIONS AND WEIGHTS FOR -6 (D) ORIFICE

Valve model type	Body material	Set pressure range	Valve connections		Threaded connections		Dimensions			Approx. weight lb (kg)
			Inlet in (DN)	Outlet in (DN)	Inlet	Outlet	A in (mm)	B in (mm)	C max ^[2] in (mm)	
81, 83	Brass	20 to 1410 psig	½, ¾ and 1 (15, 20 and 25)	1 (25)	FNPT	FNPT	3.70 (94)	1.81 (46)	10.99 (279)	8.3 (3.8)
	CS, SS	(1.4 to 97.2 barg) ^[1]	¾ and 1 (20 and 25)	1 (25)	MNPT	FNPT	3.80 (97)	1.81 (46)	10.99 (279)	8.3 (3.8)
81, 83	Brass	1411 to 9600 psig	½, ¾ and 1 (15, 20 and 25)	1 (25)	FNPT	FNPT	3.70 (94)	1.81 (46)	14.18 (360)	13.3 (6.0)
	CS, SS	(97.3 to 662 barg)	¾ and 1 (20 and 25)	1 (25)	MNPT	FNPT	3.80 (97)	1.81 (46)	14.20 (361)	13.3 (6.0)

NOTES

- Normal set pressure range for Type 81: 100 to 1410 psig (6.9 to 97.2 barg).
- Add 0.90" (23 mm) to 'C max.' dimension for numbered orifice Types 81 and 83 with packed lift lever option.

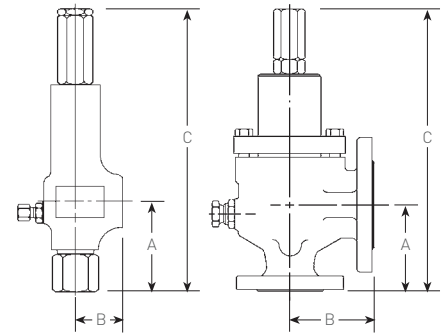

ANDERSON GREENWOOD DIRECT SPRING OPERATED PRESSURE RELIEF VALVES

DIMENSIONS AND WEIGHTS - SERIES 80

DIMENSIONS AND WEIGHTS FOR -8 (E) ORIFICE

Valve model type	Body material	Set pressure range	Valve connections				Dimensions			Approx. weight lb (kg)
			Inlet in (DN)	Outlet in (DN)	Threaded connections		A in (mm)	B in (mm)	C max ^[2] in (mm)	
81, 83	Brass	20 to 600 psig	¾ and 1 (20 and 25)	1 (25)	FNPT	FNPT	3.70 (94)	1.81 (46.0)	10.99 (279)	8.3 (3.8)
	CS, SS	(1.4 to 41.4 barg) ^[1]	¾ and 1 (20 and 25)	1 (25)	MNPT	FNPT	3.80 (97)	1.81 (46.0)	10.99 (279)	8.3 (3.8)
81, 83	Brass	601 to 4000 psig	¾ and 1 (20 and 25)	1 (25)	FNPT	FNPT	3.70 (94)	1.81 (46.0)	14.10 (358)	13.8 (6.3)
	CS, SS	(41.5 to 276 barg)	¾ and 1 (20 and 25)	1 (25)	MNPT	FNPT	3.80 (97)	1.81 (46.0)	14.20 (361)	13.8 (6.3)
81P	Brass	50 to 600 psig	¾ and 1 (20 and 25)	1 (25)	FNPT	FNPT	3.70 (94)	1.81 (46.0)	10.81 (275)	8.3 (3.8)
	CS, SS	(3.4 to 41.4 barg)	¾ and 1 (20 and 25)	1 (25)	MNPT	FNPT	3.80 (97)	1.81 (46.0)	10.95 (278)	8.3 (3.8)
81P	Brass	601 to 4000 psig	¾ and 1 (20 and 25)	1 (25)	FNPT	FNPT	3.70 (94)	1.81 (46.0)	14.10 (358)	13.8 (6.3)
	CS, SS	(41.5 to 276 barg)	¾ and 1 (20 and 25)	1 (25)	MNPT	FNPT	3.80 (97)	1.81 (46.0)	14.20 (361)	13.8 (6.3)
81, 81P	CS, SS	4001 to 6000 psig (276.1 to 414 barg)	1½ (40)	2 (50)	FNPT	FNPT	3.41 (87)	3.50 (89)	19.60 (498)	25.0 (11.4)

NOTES

- Normal set pressure range for Type 81: 50 to 600 psig (3.5 to 41.4 barg).
- Add 0.90" (23 mm) to 'C max.' dimension for numbered orifice Types 81, 83, and 81P with packed lift lever option.
Add 2.0" (102 mm) to 'C max.' dimension for Type 81-E orifice with set pressure range 4001 to 6000 psig (276 to 414 barg) with packed lift lever option.
Add 1.75" (45 mm) to 'C max.' dimension for Type 81P-E orifice with set pressure range 4001 to 6000 psig (276 to 414 barg) with packed lift lever option.

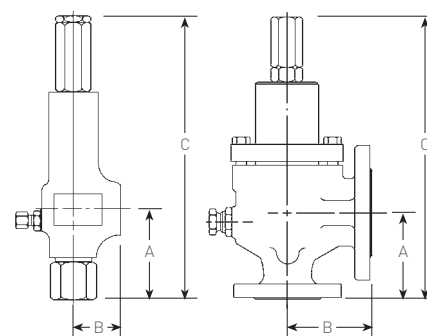

ANDERSON GREENWOOD DIRECT SPRING OPERATED PRESSURE RELIEF VALVES

DIMENSIONS AND WEIGHTS - SERIES 80

TYPES 81, 83 AND 81P LAP JOINT INLET FLANGE CONNECTIONS FOR -4 ORIFICE SRVS, CS AND SS BODY MATERIAL

Valve size in (DN)	Set pressure range	Dimensions ^[5]		ANSI inlet flange					
				150#	300#	600#	900#	1500#	2500#
½ x 1 (15 x 25)	20 to 4000 psig (1.4 to 275.8 barg) ^{[1][2][3]}	A	in	5.16	5.16	5.16	5.16	5.16	5.66
			(mm)	(131.1)	(131.1)	(131.1)	(131.1)	(131.1)	(144)
		B	in	4.75	4.75	4.75	4.75	4.75	4.75
			(mm)	(121)	(121)	(121)	(121)	(121)	(121)
		C max.	in	12.46	12.46	12.46	12.46	12.46	13.0
			(mm)	(316.5)	(317)	(317)	(317)	(317)	(330)
Wt.	lb	13.0	14.0	14.0	20.00	20.00	20.00		
	(kg)	(5.9)	(6.4)	(6.4)	(9.1)	(9.1)	(9.1)		
½ x 1 (15 x 25)	4.001 to 6000 psig (275.9 to 413.7 barg) ^[3]	A	in	----	----	----	----	----	5.66
			(mm)	----	----	----	----	----	(144)
		B	in	----	----	----	----	----	4.75
			(mm)	----	----	----	----	----	(121)
		C max.	in	----	----	----	----	----	16.18
			(mm)	----	----	----	----	----	(411)
Wt.	lb	----	----	----	----	----	24.0		
	(kg)	----	----	----	----	----	(10.9)		
¾ x 1 (20 x 25)	20 to 4000 psig (1.4 to 275.8 barg) ^{[1][2][3]}	A	in	5.16	5.16	5.16	5.41	5.41	5.72
			(mm)	(131)	(131)	(131)	(137.5)	(137.5)	(145.3)
		B	in	4.75	4.75	4.75	4.75	4.75	4.75
			(mm)	(121)	(121)	(121)	(121)	(121)	(121)
		C max.	in	12.46	12.46	12.46	12.75	12.75	13.10
			(mm)	(317)	(317)	(317)	(324)	(324)	(333)
Wt.	lb	13.0	14.0	14.0	18.0	18.0	18.0		
	(kg)	(5.9)	(6.4)	(6.4)	(8.2)	(8.2)	(8.2)		
¾ x 1 (20 x 25)	4001 to 6000 psig (275.9 to 413.7 barg) ^[3]	A	in	----	----	----	----	----	5.72
			(mm)	----	----	----	----	----	(145.3)
		B	in	----	----	----	----	----	4.75
			(mm)	----	----	----	----	----	(121)
		C max.	in	----	----	----	----	----	16.30
			(mm)	----	----	----	----	----	(414)
Wt.	lb	----	----	----	----	----	23.0		
	(kg)	----	----	----	----	----	(10.4)		

NOTES

- Normal set pressure range for Type 81: 100 to 4000 psig (6.9 to 275.8 barg) and Type 83: 20 to 2000 psig (1.3 to 137.8 barg).
- Set pressure range for Type 81P: 50 to 1160 psig (3.5 to 80.0 barg).
- Set pressure range for Type 81P: 1,161 to 6000 psig (80.1 to 413.7 barg).
- Add 0.90" (23 mm) to 'C max.' dimension for numbered orifice Types 81, 83 and 81P with packed lift lever option.
- Dimensions do not vary with outlet flange ratings.

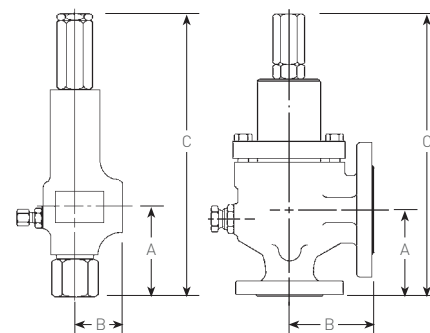

ANDERSON GREENWOOD DIRECT SPRING OPERATED PRESSURE RELIEF VALVES

DIMENSIONS AND WEIGHTS - SERIES 80

TYPES 81, 83 AND 81P LAP JOINT INLET FLANGE CONNECTIONS FOR -4 ORIFICE SRVS, CS AND SS BODY MATERIAL - CONTINUED

Valve size in (DN)	Set pressure range	Dimensions ^[5]		ANSI inlet flange					
				150#	300#	600#	900#	1500#	2500#
1 x 1 (25 x 25)	20 to 4000 psig (1.4 to 275.8 barg) ^{[1][2][3]}	A	in	5.29	5.29	5.29	6.16	6.16	6.16
			(mm)	(134)	(134)	(134)	(157)	(157)	(157)
		B	in	4.75	4.75	4.75	4.75	4.75	4.75
			(mm)	(121)	(121)	(121)	(121)	(121)	(121)
		C max.	in	12.60	12.60	12.60	13.46	13.46	13.46
			(mm)	(320)	(320)	(320)	(342)	(342)	(342)
Wt.	(kg)	14.0	14.0	15.0	20.0	20.0	24.0		
1 x 1 (25 x 25)	4001 to 6000 psig (275.9 to 413.7 barg) ^[3]	A	in	----	----	----	----	----	6.16
			(mm)	----	----	----	----	----	(157)
		B	in	----	----	----	----	----	4.75
			(mm)	----	----	----	----	----	(121)
		C max.	in	----	----	----	----	----	16.66
			(mm)	----	----	----	----	----	(423)
Wt.	(kg)	----	----	----	----	----	29.0		
								(13.2)	

NOTES

- Normal set pressure range for Type 81: 100 to 4000 psig (6.9 to 275.8 barg) and Type 83: 20 to 2000 psig (1.3 to 137.8 barg).
- Set pressure range for Type 81P: 50 to 1160 psig (3.5 to 80.0 barg).
- Set pressure range for Type 81P: 1,161 to 6000 psig (80.1 to 413.7 barg).
- Add 0.90" (23 mm) to 'C max.' dimension for numbered orifice Types 81, 83 and 81P with packed lift lever option.
- Dimensions do not vary with outlet flange ratings.

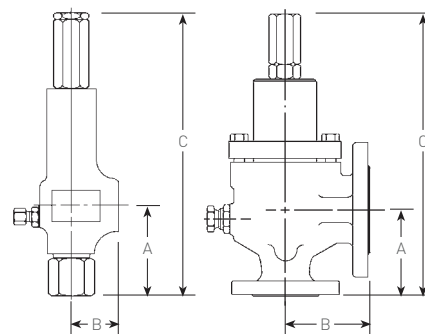

ANDERSON GREENWOOD DIRECT SPRING OPERATED PRESSURE RELIEF VALVES

DIMENSIONS AND WEIGHTS - SERIES 80

TYPES 81 AND 83 LAP JOINT INLET FLANGE CONNECTIONS FOR -6 (D) ORIFICE SRVS, CS AND SS BODY MATERIAL

Valve size in (DN)	Set pressure range	Dimensions ^{[2][3]}		ANSI inlet flange					
				150#	300#	600#	900#	1500#	2500#
½ x 1 (15 x 25)	20 to 1410 psig (1.4 to 97.2 barg) ^[1]	A	in	5.16	5.16	5.16	5.16	5.16	5.66
			(mm)	(131)	(131)	(131)	(131)	(131)	(144)
		B	in	4.75	4.75	4.75	4.75	4.75	4.75
			(mm)	(121)	(121)	(121)	(121)	(121)	(121)
		C max.	in	12.46	12.46	12.46	12.46	12.46	13.00
(mm)	(317)	(317)	(317)	(317)	(317)	(317)	(330)		
Wt.	lb	13.0	14.0	14.0	20.0	20.0	20.0		
	(kg)	(5.9)	(6.4)	(6.4)	(9.1)	(9.1)	(9.1)		
½ x 1 (15 x 25)	1411 to 6000 psig (97.3 to 413.7 barg)	A	in	-----	-----	5.16	5.16	5.16	5.66
			(mm)	-----	-----	(131)	(131)	(131)	(144)
		B	in	-----	-----	4.75	4.75	4.75	4.75
			(mm)	-----	-----	(121)	(121)	(121)	(121)
		C max.	in	-----	-----	15.66	15.66	15.66	16.18
(mm)	-----	-----	(398)	(398)	(398)	(411)			
Wt.	lb	-----	-----	18.0	23.0	23.0	24.0		
	(kg)	-----	-----	(8.2)	(10.4)	(10.4)	(10.9)		
¾ x 1 (20 x 25)	20 to 1410 psig (1.4 to 97.2 barg) ^[1]	A	in	5.16	5.16	5.16	5.41	5.41	5.79
			(mm)	(131)	(131)	(131)	(138)	(138)	(147)
		B	in	4.75	4.75	4.75	4.75	4.75	4.75
			(mm)	(121)	(121)	(121)	(121)	(121)	(121)
		C max.	in	12.46	12.46	12.46	12.75	12.75	13.10
(mm)	(317)	(317)	(317)	(324)	(324)	(333)			
Wt.	lb	13.0	14.0	14.0	18.0	18.0	18.0		
	(kg)	(5.9)	(6.4)	(6.4)	(8.2)	(8.2)	(8.2)		
¾ x 1 (20 x 25)	1411 to 6000 psig (97.3 to 413.7 barg)	A	in	-----	-----	5.16	5.41	5.41	5.79
			(mm)	-----	-----	(131)	(138)	(138)	(147)
		B	in	-----	-----	4.75	4.75	4.75	4.75
			(mm)	-----	-----	(121)	(121)	(121)	(121)
		C max.	in	-----	-----	15.66	15.94	15.94	16.30
(mm)	-----	-----	(398)	(405)	(405)	(414)			
Wt.	lb	-----	-----	19.0	23.0	23.0	23.0		
	(kg)	-----	-----	(8.6)	(10.4)	(10.4)	(10.4)		

NOTES

1. Normal set pressure range for Type 81: 100 to 1410 psig (6.9 to 97 barg).
2. Add 0.90" (23 mm) to 'C max.' dimension for numbered orifice Types 81 and 83 with packed lift lever option.
3. Dimensions do not vary with outlet flange pressure rating.

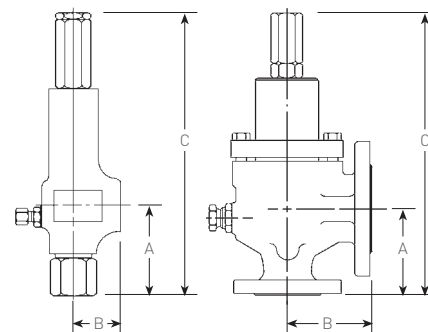

ANDERSON GREENWOOD DIRECT SPRING OPERATED PRESSURE RELIEF VALVES

DIMENSIONS AND WEIGHTS - SERIES 80

TYPES 81 AND 83 LAP JOINT INLET FLANGE CONNECTIONS FOR -6 (D) ORIFICE SRVS, CS AND SS BODY MATERIAL - CONTINUED

Valve size in (DN)	Set pressure range	Dimensions ^{[2][3]}		ANSI inlet flange					
				150#	300#	600#	900#	1500#	2500#
1 x 1 (25 x 25)	20 to 1410 psig (1.4 to 97.2 barg) ^[1]	A	in	5.29	5.29	5.29	6.16	6.16	6.16
			(mm)	(134)	(134)	(134)	(157)	(157)	(157)
		B	in	4.75	4.75	4.75	4.75	4.75	4.75
			(mm)	(121)	(121)	(121)	(121)	(121)	(121)
		C max.	in	12.60	12.60	12.60	13.46	13.46	13.46
			(mm)	(320)	(320)	(320)	(342)	(342)	(342)
Wt.	lb	14.0	14.0	15.0	20.0	20.0	24.0		
	(kg)	(6.4)	(6.4)	(6.8)	(9.1)	(9.1)	(10.9)		
1 x 1 (25 x 25)	1411 to 6000 psig (97.3 to 413.7 barg)	A	in	----	----	5.29	6.16	6.16	6.16
			(mm)	----	----	(134)	(157)	(157)	(157)
		B	in	----	----	4.75	4.75	4.75	4.75
			(mm)	----	----	(121)	(121)	(121)	(121)
		C max.	in	----	----	15.80	16.66	16.66	16.66
			(mm)	----	----	(401)	(423)	(423)	(423)
Wt.	lb	----	----	20.0	25.0	25.0	29.0		
	(kg)	----	----	(9.1)	(11.4)	(11.4)	(13.2)		

NOTES

- Normal set pressure range for Type 81: 100 to 1410 psig (6.9 to 97 barg) and Type 83: 20 to 2000 psig (1.3 to 137.8 barg).
- Add 0.90" (23 mm) to 'C max.' dimension for numbered orifice Types 81 and 83 with packed lift lever option.
- Dimensions do not vary with outlet flange pressure rating.

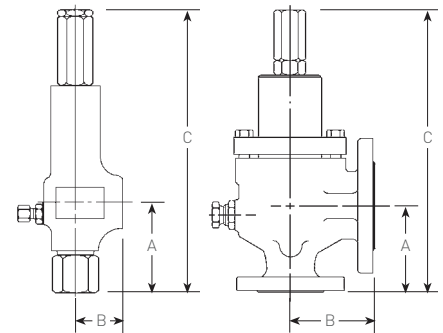

ANDERSON GREENWOOD DIRECT SPRING OPERATED PRESSURE RELIEF VALVES

DIMENSIONS AND WEIGHTS - SERIES 80

TYPES 81, 83 AND 81P LAP JOINT INLET FLANGE CONNECTIONS FOR -8 (E) ORIFICE SRVS, CS AND SS BODY MATERIAL

Valve size in (DN)	Set pressure range	Dimensions ^[3]		ANSI inlet flange					
				150#	300#	600#	900#	1500#	2500#
3/4 x 1 (20 x 25)	20 to 600 psig (1.4 to 41.4 barg) ^[1]	A	in	5.16	5.16	5.16	5.41	5.41	5.79
			(mm)	(131)	(131)	(131)	(138)	(138)	(147)
		B	in	4.75	4.75	4.75	4.75	4.75	4.75
			(mm)	(121)	(121)	(121)	(121)	(121)	(121)
		C max.	in	12.46	12.46	12.46	12.75	12.75	13.10
			(mm)	(317)	(317)	(317)	(324)	(324)	(333)
Wt.	lb	13.0	14.0	14.0	18.0	18.0	18.0		
	(kg)	(5.9)	(6.4)	(6.4)	(8.2)	(8.2)	(8.2)		
3/4 x 1 (20 x 25)	601 to 4000 psig (41.5 to 276 barg) ^[2]	A	in	----	5.16	5.16	5.41	5.41	5.79
			(mm)	----	(131)	(131)	(138)	(138)	(147)
		B	in	----	4.75	4.75	4.75	4.75	4.75
			(mm)	----	(121)	(121)	(121)	(121)	(121)
		C max.	in	----	15.66	15.66	15.94	15.94	16.30
			(mm)	----	(398)	(398)	(405)	(405)	(414)
Wt.	lb	----	19.0	19.0	23.0	23.0	23.0		
	(kg)	----	(8.6)	(8.6)	(10.4)	(10.4)	(10.4)		
1 x 1 (25 x 25)	20 to 600 psig (1.4 to 41.4 barg) ^[1]	A	in	5.29	5.29	5.29	6.16	6.16	6.16
			(mm)	(134)	(134)	(134)	(157)	(157)	(157)
		B	in	4.75	4.75	4.75	4.75	4.75	4.75
			(mm)	(121)	(121)	(121)	(121)	(121)	(121)
		C max.	in	12.60	12.60	12.60	13.46	13.46	13.46
			(mm)	(320)	(320)	(320)	(342)	(342)	(342)
Wt.	lb	14.0	14.0	15.0	20.0	20.0	23.0		
	(kg)	(6.4)	(6.4)	(6.8)	(9.1)	(9.1)	(10.9)		
1 x 1 (25 x 25)	601 to 4000 psig (41.5 to 276 barg) ^[2]	A	in	----	5.29	5.29	6.16	6.16	6.16
			(mm)	----	(134)	(134)	(157)	(157)	(157)
		B	in	----	4.75	4.75	4.75	4.75	4.75
			(mm)	----	(121)	(121)	(121)	(121)	(121)
		C max.	in	----	15.80	15.80	16.66	16.66	16.66
			(mm)	----	(401)	(401)	(423)	(423)	(423)
Wt.	lb	----	19.0	20.0	25.0	25.0	29.0		
	(kg)	----	(8.6)	(9.1)	(11.4)	(11.4)	(13.2)		

NOTES

- Normal set pressure range for Types 81 and 81P: 50 to 600 psig (3.5 to 41.4 barg) and Type 83: 20 to 2000 psig (1.3 to 137.8 barg).
- Add 0.90" (23 mm) to 'C max.' dimension for numbered orifice Types 81, 83 and 81P with packed lift lever option.
- Dimensions do not vary with outlet flange pressure rating.

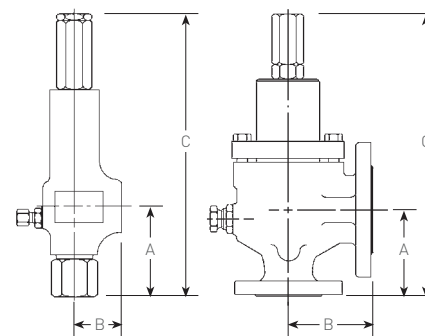

ANDERSON GREENWOOD DIRECT SPRING OPERATED PRESSURE RELIEF VALVES

DIMENSIONS AND WEIGHTS - SERIES 80

TYPES 81, 83 AND 81P SLIP-ON FLANGED CONNECTIONS FOR -4 ORIFICE SRVS, CS AND SS BODY MATERIAL

Valve size in (DN)	Set pressure range	Dimensions ^[5]		ANSI inlet flange					
				150#	300#	600#	900#	1500#	2500#
1/2 x 1 (15 x 25)	20 to 4000 psig (1.4 to 275.8 barg) ^{[1][2]}	A	in	4.82	4.82	4.97	4.97	4.97	5.97
			(mm)	(122)	(122.4)	(126.2)	(126.2)	(126.2)	(151.6)
		B	in	4.75	4.75	4.75	4.75	4.75	6.75
			(mm)	(121)	(120.6)	(120.6)	(120.6)	(120.6)	(171.4)
		C max.	in	12.12	12.12	12.27	12.27	12.27	13.27
			(mm)	(308)	(308)	(312)	(312)	(312)	(337)
Wt.	lb	12.0	13.0	13.0	15.0	15.0	19.0		
	(kg)	(5.5)	(5.9)	(5.9)	(6.8)	(6.8)	(8.6)		
1/2 x 1 (15 x 25)	4.001 to 6000 psig (275.9 to 413.7 barg) ^[3]	A	in	----	----	----	----	----	5.97
			(mm)	----	----	----	----	----	(151.6)
		B	in	----	----	----	----	----	6.75
			(mm)	----	----	----	----	----	(171.4)
		C max.	in	----	----	----	----	----	16.47
			(mm)	----	----	----	----	----	(418.3)
Wt.	lb	----	----	----	----	----	24.0		
	(kg)	----	----	----	----	----	(10.9)		
3/4 x 1 (20 x 25)	20 to 4000 psig (1.4 to 275.8 barg) ^{[1][2]}	A	in	4.72	4.72	4.72	4.72	4.72	5.72
			(mm)	(120)	(120)	(120)	(120)	(120)	(145.3)
		B	in	4.75	4.75	4.75	4.75	4.75	6.75
			(mm)	(121)	(121)	(121)	(121)	(121)	(171.4)
		C max.	in	12.02	12.02	12.02	12.02	12.02	13.02
			(mm)	(305)	(305)	(305)	(305)	(305)	(331)
Wt.	lb	13.0	14.0	14.0	17.0	17.0	20.0		
	(kg)	(5.9)	(6.4)	(6.4)	(7.7)	(7.7)	(9.1)		
3/4 x 1 (20 x 25)	4001 to 6000 psig (275.9 to 413.7 barg) ^[3]	A	in	----	----	----	----	----	5.72
			(mm)	----	----	----	----	----	(145.3)
		B	in	----	----	----	----	----	6.75
			(mm)	----	----	----	----	----	(171.4)
		C max.	in	----	----	----	----	----	16.22
			(mm)	----	----	----	----	----	(412.0)
Wt.	lb	----	----	----	----	----	25.0		
	(kg)	----	----	----	----	----	(11.3)		

NOTES

- Normal set pressure range for Type 81: 100 to 4000 psig (6.9 to 275.8 barg) and Type 83: 20 to 2000 psig (1.3 to 137.8 barg).
- Set pressure range for Type 81P: 50 to 1160 psig (3.5 to 80.0 barg).
- Set pressure range for Type 81P: 1,161 to 6000 psig (80.1 to 413.7 barg).
- Add 0.90" (23 mm) to 'C max.' dimension for numbered orifice Types 81, 83 and 81P with packed lift lever option.
- Dimensions do not vary with outlet flange ratings.

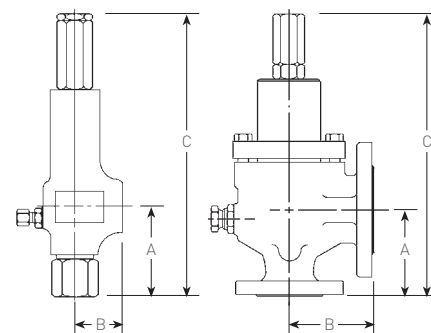

ANDERSON GREENWOOD DIRECT SPRING OPERATED PRESSURE RELIEF VALVES

DIMENSIONS AND WEIGHTS - SERIES 80

TYPES 81, 83 AND 81P SLIP-ON FLANGED CONNECTIONS FOR -4 ORIFICE SRVS, CS AND SS BODY MATERIAL - CONTINUED

Valve size in (DN)	Set pressure range	Dimensions ^[5]		ANSI inlet flange					
				150#	300#	600#	900#	1500#	2500#
1 x 1 (25 x 25)	20 to 4000 psig (1.4 to 275.8 barg) ^{[1][2]}	A	in	4.72	4.72	4.72	5.72	5.72	5.72
			(mm)	(120)	(120)	(120)	(145.3)	(145.3)	(145.3)
		B	in	4.75	4.75	4.75	6.75	6.75	6.75
			(mm)	(121)	(121)	(121)	(171.4)	(171.4)	(171.4)
		C max.	in	12.02	12.02	12.02	13.02	13.02	13.02
			(mm)	(305)	(305)	(305)	(331)	(331)	(331)
Wt.	(kg)	13.0	14.0	15.0	20.0	20.0	23.0		
1 x 1 (25 x 25)	4001 to 6000 psig (275.9 to 413.7 barg) ^[3]	A	in	----	----	----	----	----	5.72
			(mm)	----	----	----	----	----	(145.3)
		B	in	----	----	----	----	----	6.75
			(mm)	----	----	----	----	----	(171.5)
		C max.	in	----	----	----	----	----	16.22
			(mm)	----	----	----	----	----	(412.0)
Wt.	(kg)	----	----	----	----	----	28.0		
								(12.7)	

NOTES

- Normal set pressure range for Type 81: 100 to 4000 psig (6.9 to 275.8 barg) and Type 83: 20 to 2000 psig (1.3 to 137.8 barg).
- Set pressure range for Type 81P: 50 to 1160 psig (3.5 to 80.0 barg).
- Set pressure range for Type 81P: 1,161 to 6000 psig (80.1 to 413.7 barg).
- Add 0.90" (23 mm) to 'C max.' dimension for numbered orifice Types 81, 83 and 81P with packed lift lever option.
- Dimensions do not vary with outlet flange ratings.

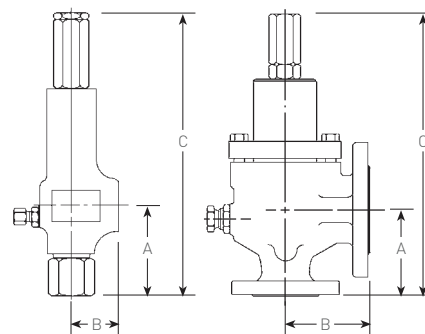

ANDERSON GREENWOOD DIRECT SPRING OPERATED PRESSURE RELIEF VALVES

DIMENSIONS AND WEIGHTS - SERIES 80

TYPES 81 AND 83 SLIP-ON FLANGED CONNECTIONS FOR -6 (D) ORIFICE SRVS, CS AND SS BODY MATERIAL

Valve size in (DN)	Set pressure range	Dimensions ^{[2][3]}		ANSI inlet flange					
				150#	300#	600#	900#	1500#	2500#
½ x 1 (15 x 25)	20 to 1410 psig (1.4 to 97.2 barg) ^[1]	A	in	4.82	4.82	4.97	4.97	4.97	5.97
			(mm)	(122)	(122)	(126)	(126)	(126)	(152)
		B	in	4.75	4.75	4.75	4.75	4.75	6.75
			(mm)	(121)	(121)	(121)	(121)	(121)	(172)
		C max.	in	12.12	12.12	12.27	12.27	12.27	13.27
			(mm)	(308)	(308)	(312)	(312)	(312)	(337)
		Wt.	lb	12.0	13.0	13.0	15.0	15.0	19.0
			(kg)	(5.4)	(5.9)	(5.9)	(6.8)	(6.8)	(8.6)
½ x 1 (15 x 25)	1411 to 6000 psig (97.3 to 413.7 barg)	A	in	----	----	4.97	4.97	4.97	5.97
			(mm)	----	----	(126)	(126)	(126)	(152)
		B	in	----	----	4.75	4.75	4.75	6.75
			(mm)	----	----	(121)	(121)	(121)	(172)
		C max.	in	----	----	15.47	15.47	15.47	16.47
			(mm)	----	----	(393)	(393)	(393)	(418)
		Wt.	lb	----	----	18.0	20.0	20.0	24.0
			(kg)	----	----	(8.2)	(9.1)	(9.1)	(10.9)
¾ x 1 (20 x 25)	20 to 1410 psig (1.4 to 97.2 barg) ^[1]	A	in	4.72	4.72	4.72	4.72	4.72	5.72
			(mm)	(120)	(120)	(120)	(120)	(120)	(145)
		B	in	4.75	4.75	4.75	4.75	4.75	6.75
			(mm)	(121)	(121)	(121)	(121)	(121)	(172)
		C max.	in	12.02	12.02	12.02	12.02	12.02	13.02
			(mm)	(305)	(305)	(305)	(305)	(305)	(331)
		Wt.	lb	13.0	14.0	14.0	17.0	17.0	20.0
			(kg)	(5.9)	(6.4)	(6.4)	(7.7)	(7.7)	(9.1)
¾ x 1 (20 x 25)	1411 to 6000 psig (97.3 to 413.7 barg)	A	in	----	----	4.72	4.72	4.72	5.72
			(mm)	----	----	(120)	(120)	(120)	(145)
		B	in	----	----	4.75	4.75	4.75	6.75
			(mm)	----	----	(121)	(121)	(121)	(172)
		C max.	in	----	----	15.22	15.22	15.22	16.22
			(mm)	----	----	(387)	(387)	(387)	(387)
		Wt.	lb	----	----	19.0	22.0	22.0	25.0
			(kg)	----	----	(8.6)	(10.0)	(10.0)	(11.3)

NOTES

- Normal set pressure range for Type 81: 100 to 1410 psig (6.9 to 97 barg) and Type 83: 20 to 2000 psig (1.3 to 137.8 barg).
- Add 0.90" (23 mm) to 'C max.' dimension for numbered orifice Types 81 and 83 with packed lift lever option.
- Dimensions do not vary with outlet flange pressure rating.

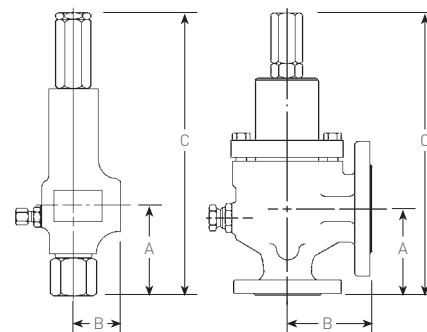

ANDERSON GREENWOOD DIRECT SPRING OPERATED PRESSURE RELIEF VALVES

DIMENSIONS AND WEIGHTS - SERIES 80

TYPES 81 AND 83 SLIP-ON FLANGED CONNECTIONS FOR -6 (D) ORIFICE SRVS, CS AND SS BODY MATERIAL - CONTINUED

Valve size in (DN)	Set pressure range	Dimensions ^{[2][3]}		ANSI inlet flange					
				150#	300#	600#	900#	1500#	2500#
1 x 1 (25 x 25)	20 to 1410 psig (1.4 to 97.2 barg) ^[1]	A	in	4.72	4.72	4.72	5.72	5.72	5.72
			(mm)	(120)	(120)	(120)	(145)	(145)	(145)
		B	in	4.75	4.75	4.75	6.75	6.75	6.75
			(mm)	(121)	(121)	(121)	(172)	(172)	(172)
		C max.	in	12.02	12.02	12.02	13.02	13.02	13.02
			(mm)	(305)	(305)	(305)	(331)	(331)	(331)
Wt.	lb	13.0	14.0	15.0	20.0	20.0	23.0		
	(kg)	(5.9)	(6.4)	(6.8)	(9.1)	(9.1)	(10.5)		
1 x 1 (25 x 25)	1411 to 6000 psig (97.3 to 413.7 barg) ^[3]	A	in	----	----	4.72	5.72	5.72	5.72
			(mm)	----	----	(120)	(145)	(145)	(145)
		B	in	----	----	4.75	6.75	6.75	6.75
			(mm)	----	----	(121)	(172)	(172)	(172)
		C max.	in	----	----	15.22	16.22	16.22	16.22
			(mm)	----	----	(387)	(412)	(412)	(412)
Wt.	lb	----	----	20.0	25.0	25.0	28.0		
	(kg)	----	----	(9.1)	(11.4)	(11.4)	(12.7)		

NOTES

- Normal set pressure range for Type 81: 100 to 1410 psig (6.9 to 97 barg) and Type 83: 20 to 2000 psig (1.3 to 137.8 barg).
- Add 0.90" (23 mm) to 'C max.' dimension for numbered orifice Types 81 and 83 with packed lift lever option.
- Dimensions do not vary with outlet flange pressure rating.

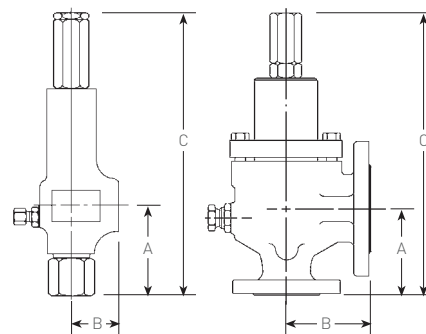

ANDERSON GREENWOOD DIRECT SPRING OPERATED PRESSURE RELIEF VALVES

DIMENSIONS AND WEIGHTS - SERIES 80

TYPES 81, 83 AND 81P SLIP-ON FLANGED CONNECTIONS FOR -8 (E) ORIFICE SRVS, CS AND SS BODY MATERIAL

Valve size in (DN)	Set pressure range	Dimensions ^[3]		ANSI inlet flange					
				150#	300#	600#	900#	1500#	2500#
3/4 x 1 (20 x 25)	20 to 600 psig (1.4 to 41.4 barg) ^[1]	A	in	4.72	4.72	4.72	4.72	4.72	5.72
			(mm)	(120)	(120)	(120)	(120)	(120)	(145)
		B	in	4.75	4.75	4.75	4.75	4.75	6.75
			(mm)	(121)	(121)	(121)	(121)	(121)	(172)
		C max.	in	12.02	12.02	12.02	12.02	12.02	13.02
			(mm)	(305)	(305)	(305)	(305)	(305)	(331)
Wt.	lb	13.0	14.0	14.0	17.0	17.0	20.0		
	(kg)	(5.9)	(6.4)	(6.4)	(7.7)	(7.7)	(9.1)		
3/4 x 1 (20 x 25)	601 to 4000 psig (41.5 to 276 barg) ^[3]	A	in	----	4.72	4.72	4.72	4.72	5.72
			(mm)	----	(120)	(120)	(120)	(120)	(145)
		B	in	----	4.75	4.75	4.75	4.75	6.75
			(mm)	----	(121)	(121)	(121)	(121)	(172)
		C max.	in	----	15.22	15.22	15.22	15.22	16.22
			(mm)	----	(387)	(387)	(387)	(387)	(412)
Wt.	lb	----	19.0	19.0	22.0	22.0	25.0		
	(kg)	----	(8.6)	(8.6)	(10.0)	(10.0)	(11.4)		
1 x 1 (25 x 25)	20 to 600 psig (1.4 to 41.4 barg) ^[1]	A	in	4.72	4.72	4.72	5.72	5.72	5.72
			(mm)	(120)	(120)	(120)	(145)	(145)	(145)
		B	in	4.75	4.75	4.75	6.75	6.75	6.75
			(mm)	(121)	(121)	(121)	(172)	(172)	(172)
		C max.	in	12.02	12.02	12.02	13.02	13.02	13.02
			(mm)	(305.0)	(305.0)	(305.0)	(331)	(331)	(331)
Wt.	lb	13.0	14.0	15.0	20.0	20.0	23.0		
	(kg)	(5.9)	(6.4)	(6.8)	(9.1)	(9.1)	(10.5)		
1 x 1 (25 x 25)	601 to 4000 psig (41.5 to 276 barg) ^[3]	A	in	----	4.72	4.72	5.72	5.72	5.72
			(mm)	----	(120)	(120)	(145)	(145)	(145)
		B	in	----	4.75	4.75	6.75	6.75	6.75
			(mm)	----	(121)	(121)	(172)	(172)	(172)
		C max.	in	----	15.22	15.22	16.22	16.22	16.22
			(mm)	----	(387)	(387)	(412)	(412)	(412)
Wt.	lb	----	19.0	20.0	25.0	25.0	28.0		
	(kg)	----	(8.6)	(9.1)	(11.4)	(11.4)	(12.7)		

NOTES

1. Normal set pressure range for Types 81 and 81P: 50 to 600 psig (3.5 to 41.4 barg) and Type 83: 20 to 2000 psig (1.3 to 137.8 barg).
2. Add 0.90" (23 mm) to 'C max.' dimension for numbered orifice Types 81, 83 and 81P with packed lift lever option.
3. Dimensions do not vary with outlet flange pressure rating.

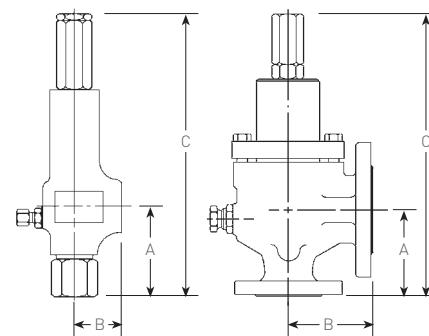

ANDERSON GREENWOOD DIRECT SPRING OPERATED PRESSURE RELIEF VALVES

DIMENSIONS AND WEIGHTS - SERIES 80

TYPES 81, 83 AND 81P SLIP-ON FLANGED CONNECTIONS FOR -8 (E) ORIFICE SRVS, CS AND SS BODY MATERIAL - CONTINUED

Valve size in (DN)	Set pressure range	Dimensions ⁽³⁾		ANSI inlet flange					
				150#	300#	600#	900#	1500#	2500#
1 x 2 (25 x 50)	20 to 600 psig (1.4 to 41.4 barg) ⁽¹⁾	A	in	4.72	4.72	4.72	5.72	5.72	5.72
			(mm)	(120)	(120)	(120)	(145)	(145)	(145)
		B	in	4.75	4.75	4.75	6.75	6.75	6.75
			(mm)	(121)	(121)	(121)	(172)	(172)	(172)
		C max.	in	12.02	12.02	12.02	13.02	13.02	13.02
			(mm)	(305)	(305)	(305)	(331)	(331)	(331)
Wt.	lb	16.0	17.0	18.0	25.0	25.0	28.0		
	(kg)	(7.3)	(7.7)	(8.2)	(11.4)	(11.4)	(12.7)		
1 x 2 (25 x 50)	601 to 4000 psig (41.1 to 276 barg)	A	in	----	4.72	4.72	5.72	5.72	5.72
			(mm)	----	(120)	(120)	(145)	(145)	(145)
		B	in	----	4.75	4.75	6.75	6.75	6.75
			(mm)	----	(121)	(121)	(172)	(172)	(172)
		C max.	in	----	15.22	15.22	16.22	16.22	16.22
			(mm)	----	(387)	(387)	(412)	(412)	(412)
Wt.	lb	----	22.0	23.0	30.0	30.0	33.0		
	(kg)	----	(10)	(10.5)	(13.6)	(13.6)	(15)		

NOTES

1. Normal set pressure range for Types 81 and 81P: 50 to 600 psig (3.5 to 41.4 barg) and Type 83: 20 to 2000 psig (1.3 to 137.8 barg).
2. Add 0.90" (23 mm) to 'C max.' dimension for numbered orifice Types 81, 83 and 81P with packed lift lever option.
3. Dimensions do not vary with outlet flange pressure rating.

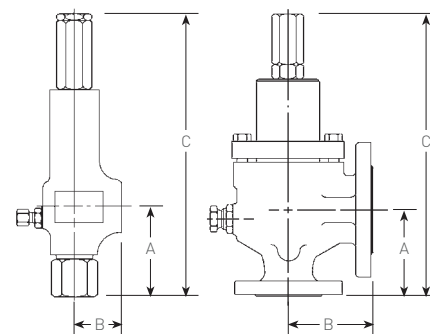

ANDERSON GREENWOOD DIRECT SPRING OPERATED PRESSURE RELIEF VALVES

DIMENSIONS AND WEIGHTS - SERIES 80

TYPES 81, 83 AND 81P WELDNECK FLANGE CONNECTIONS FOR -4 ORIFICE SRVS, CS AND SS BODY MATERIAL

Valve size		Dimensions		ANSI inlet flange						ANSI outlet flange								
in (DN)	Set pressure range			150#	300#	600#	900#	1500#	2500#									
1/2 x 1 (15 x 25)	20 to 4000 psig (1.4 to 275.8 barg) ^{[1][2]}	A	in	5.51	5.70	5.94	5.66	5.66	6.18	150#								
			(mm)	(139.9)	(144.8)	(150.9)	(143.7)	(143.7)	(156.9)									
		B	in	4.06	4.06	4.06	4.06	4.06	4.06		300#							
			(mm)	(103.1)	(103.1)	(103.1)	(103.1)	(103.1)	(103.1)									
		C max.	in	12.80	13.00	13.25	12.96	12.96	13.50			600#						
			(mm)	(325.1)	(330.2)	(336.6)	(329.2)	(329.2)	(342.9)									
		Wt.	lb	13.00	13.00	14.00	18.00	18.00	19.00				900#					
			(kg)	(5.9)	(5.9)	(6.4)	(8.2)	(8.2)	(8.6)									
		A	in	----	5.70	5.94	5.66	5.66	6.18					300#				
			(mm)	----	(144.8)	(150.9)	(143.7)	(143.7)	(156.9)									
		B	in	----	4.31	4.31	4.31	4.31	4.31						600#			
			(mm)	----	(109.5)	(109.5)	(109.5)	(109.5)	(109.5)									
		C max.	in	----	13.00	13.25	12.96	12.96	13.50							900#		
			(mm)	----	(330.2)	(336.6)	(329.2)	(329.2)	(342.9)									
		Wt.	lb	----	14.00	15.00	19.00	19.00	20.00								150#	
			(kg)	----	(6.4)	(6.8)	(8.6)	(8.6)	(9.1)									
		A	in	----	----	5.94	5.66	5.66	6.18									300#
			(mm)	----	----	(150.9)	(143.7)	(143.7)	(156.9)									
B	in	----	----	4.56	4.56	4.56	4.56	600#										
	(mm)	----	----	(115.8)	(115.8)	(115.8)	(115.8)											
C max.	in	----	----	13.25	12.96	12.96	13.50		900#									
	(mm)	----	----	(336.6)	(329.2)	(329.2)	(342.9)											
Wt.	lb	----	----	15.00	19.00	19.00	20.00			150#								
	(kg)	----	----	(6.8)	(8.6)	(8.6)	(9.1)											
A	in	----	----	----	----	----	6.18				300#							
	(mm)	----	----	----	----	----	(156.9)											
B	in	----	----	----	----	----	5.00					600#						
	(mm)	----	----	----	----	----	(127.0)											
C max.	in	----	----	----	----	----	13.50						900#					
	(mm)	----	----	----	----	----	(342.9)											
Wt.	lb	----	----	----	----	----	25.0							150#				
	(kg)	----	----	----	----	----	(11.3)											

NOTES

1. Normal set pressure range for Type 81: 100 to 4000 psig (6.9 to 275.8 barg) and Type 83: 20 to 2000 psig (1.4 to 137.9 barg).
2. Set pressure range for Type 81P: 50 to 1160 psig (3.5 to 80.0 barg).
3. Set pressure range for Type 81P: 1161 to 6000 psig (80.1 to 413.7 barg).
4. Add 0.90" (23 mm) to 'C max.' dimension for numbered orifice Type 81, 83 and 81P with packed lift lever option.

ANDERSON GREENWOOD DIRECT SPRING OPERATED PRESSURE RELIEF VALVES

DIMENSIONS AND WEIGHTS - SERIES 80

TYPES 81, 83 AND 81P WELDNECK FLANGE CONNECTIONS FOR -4 ORIFICE SRVS, CS AND SS BODY MATERIAL - CONTINUED

Valve size in (DN)	Set pressure range	Dimensions		ANSI inlet flange						ANSI outlet flange			
				150#	300#	600#	900#	1500#	2500#				
1/2 x 1 (15 x 25)	4001 to 6000 psig (275.9 to 413.7 barg) ^[3]	A	in	----	----	----	----	----	6.18	150#			
			(mm)	----	----	----	----	(156.9)					
		B	in	----	----	----	----	----	4.06				
			(mm)	----	----	----	----	----	(103.1)				
		C max.	in	----	----	----	----	----	16.68				
			(mm)	----	----	----	----	----	(423.7)				
		Wt.	lb	----	----	----	----	----	24.00				
			(kg)	----	----	----	----	----	(10.9)				
				A	in	----	----	----	----		----	6.18	300#
					(mm)	----	----	----	----		(156.9)		
				B	in	----	----	----	----		----	4.31	
					(mm)	----	----	----	----		----	(109.5)	
C max.	in			----	----	----	----	----	16.68				
	(mm)			----	----	----	----	----	(423.7)				
Wt.	lb			----	----	----	----	----	26.00				
	(kg)			----	----	----	----	----	(11.8)				
				A	in	----	----	----	----	----	6.18	600#	
					(mm)	----	----	----	----	(156.9)			
				B	in	----	----	----	----	----	4.56		
					(mm)	----	----	----	----	----	(115.8)		
		C max.	in	----	----	----	----	----	16.68				
			(mm)	----	----	----	----	----	(423.7)				
		Wt.	lb	----	----	----	----	----	26.00				
			(kg)	----	----	----	----	----	(11.8)				
				A	in	----	----	----	----	----	6.18		900#
					(mm)	----	----	----	----	(156.9)			
				B	in	----	----	----	----	----	5.00		
					(mm)	----	----	----	----	----	(127.0)		
C max.	in			----	----	----	----	----	16.68				
	(mm)			----	----	----	----	----	(423.7)				
Wt.	lb			----	----	----	----	----	30.00				
	(kg)			----	----	----	----	----	(13.6)				

NOTES

1. Normal set pressure range for Type 81: 100 to 4000 psig (6.9 to 275.8 barg) and Type 83: 20 to 2000 psig (1.4 to 137.9 barg).
2. Set pressure range for Type 81P: 50 to 1160 psig (3.5 to 80.0 barg).
3. Set pressure range for Type 81P: 1161 to 6000 psig (80.1 to 413.7 barg).
4. Add 0.90" (23 mm) to 'C max.' dimension for numbered orifice Type 81, 83 and 81P with packed lift lever option.

ANDERSON GREENWOOD DIRECT SPRING OPERATED PRESSURE RELIEF VALVES

DIMENSIONS AND WEIGHTS - SERIES 80

TYPES 81, 83 AND 81P WELDNECK FLANGE CONNECTIONS FOR -4 ORIFICE SRVS, CS AND SS BODY MATERIAL - CONTINUED

Valve size in (DN)	Set pressure range	Dimensions		ANSI inlet flange						ANSI outlet flange		
				150#	300#	600#	900#	1500#	2500#			
¾ x 1 (20 x 25)	20 to 4000 psig (1.4 to 275.8 barg) ^{[1][2]}	A	in	5.70	5.88	6.13	6.63	6.63	7.00	150#		
			(mm)	(144.8)	(149.4)	(150.9)	(168.4)	(168.4)	(177.8)			
		B	in	4.06	4.06	4.06	4.06	4.06	4.06			
			(mm)	(103.1)	(103.1)	(103.1)	(103.1)	(103.1)	(103.1)			
		C max.	in	13.00	13.18	13.44	13.94	13.94	14.30			
			(mm)	(330.2)	(334.8)	(341.4)	(354.1)	(354.1)	(363.2)			
		Wt.	lb	13.00	14.00	14.00	18.00	18.00	20.00			
			(kg)	(5.9)	(6.4)	(6.4)	(8.2)	(8.2)	(9.1)			
		A	in	----	5.88	6.13	6.63	6.63	7.00		300#	
			(mm)	----	(149.4)	(150.9)	(168.4)	(168.4)	(177.8)			
		B	in	----	4.31	4.31	4.31	4.31	4.31			
			(mm)	----	(109.5)	(109.5)	(109.5)	(109.5)	(109.5)			
		C max.	in	----	13.18	13.44	13.94	13.94	14.30			
			(mm)	----	(334.8)	(341.4)	(354.1)	(354.1)	(363.2)			
		Wt.	lb	----	15.00	16.00	19.00	19.00	21.00			
			(kg)	----	(6.8)	(7.3)	(8.6)	(8.6)	(9.5)			
		A	in	----	----	6.13	6.63	6.63	7.00			600#
			(mm)	----	----	(150.9)	(168.4)	(168.4)	(177.8)			
B	in	----	----	4.56	4.56	4.56	4.56					
	(mm)	----	----	(115.8)	(115.8)	(115.8)	(115.8)					
C max.	in	----	----	13.44	13.94	13.94	14.30					
	(mm)	----	----	(336.6)	(354.1)	(354.1)	(363.2)					
Wt.	lb	----	----	16.00	19.00	19.00	21.00					
	(kg)	----	----	(7.3)	(8.6)	(8.6)	(9.5)					
A	in	----	----	----	----	----	7.00	900#				
	(mm)	----	----	----	----	----	(156.9)					
B	in	----	----	----	----	----	5.00					
	(mm)	----	----	----	----	----	(127.0)					
C max.	in	----	----	----	----	----	14.30					
	(mm)	----	----	----	----	----	(342.9)					
Wt.	lb	----	----	----	----	----	26.00					
	(kg)	----	----	----	----	----	(11.8)					

NOTES

1. Normal set pressure range for Type 81: 100 to 4000 psig (6.9 to 275.8 barg) and Type 83: 20 to 2000 psig (1.4 to 137.9 barg).
2. Set pressure range for Type 81P: 50 to 1160 psig (3.5 to 80.0 barg).
3. Set pressure range for Type 81P: 1161 to 6000 psig (80.1 to 413.7 barg).
4. Add 0.90" (23 mm) to 'C max.' dimension for numbered orifice Type 81, 83 and 81P with packed lift lever option.

ANDERSON GREENWOOD DIRECT SPRING OPERATED PRESSURE RELIEF VALVES

DIMENSIONS AND WEIGHTS - SERIES 80

TYPES 81, 83 AND 81P WELDNECK FLANGE CONNECTIONS FOR -4 ORIFICE SRVS, CS AND SS BODY MATERIAL - CONTINUED

Valve size in (DN)	Set pressure range	Dimensions		ANSI inlet flange						ANSI outlet flange		
				150#	300#	600#	900#	1500#	2500#			
¾ x 1 (15 x 25)	4001 to 6000 psig (275.9 to 413.7 barg) ^[3]	A	in	----	----	----	----	----	7.00	150#		
			(mm)	----	----	----	----	(177.8)				
		B	in	----	----	----	----	----	4.06			
			(mm)	----	----	----	----	----	(103.1)			
		C max.	in	----	----	----	----	----	17.50			
			(mm)	----	----	----	----	----	(444.5)			
		Wt.	lb	----	----	----	----	----	25.00			
			(kg)	----	----	----	----	----	(11.3)			
				A	in	----	----	----	----	----	7.00	300#
					(mm)	----	----	----	----	----	(177.8)	
				B	in	----	----	----	----	----	4.31	
					(mm)	----	----	----	----	----	(109.5)	
C max.	in			----	----	----	----	----	17.50			
	(mm)			----	----	----	----	----	(444.5)			
Wt.	lb			----	----	----	----	----	27.00			
	(kg)			----	----	----	----	----	(12.2)			
				A	in	----	----	----	----	----	7.00	600#
					(mm)	----	----	----	----	----	(177.8)	
				B	in	----	----	----	----	----	4.56	
					(mm)	----	----	----	----	----	(115.8)	
		C max.	in	----	----	----	----	----	17.50			
			(mm)	----	----	----	----	----	(444.5)			
		Wt.	lb	----	----	----	----	----	27.00			
			(kg)	----	----	----	----	----	(12.2)			
				A	in	----	----	----	----	----	7.00	900#
					(mm)	----	----	----	----	----	(177.8)	
				B	in	----	----	----	----	----	5.00	
					(mm)	----	----	----	----	----	(127.0)	
C max.	in			----	----	----	----	----	17.50			
	(mm)			----	----	----	----	----	(444.5)			
Wt.	lb			----	----	----	----	----	31.00			
	(kg)			----	----	----	----	----	(14.1)			

NOTES

1. Normal set pressure range for Type 81: 100 to 4000 psig (6.9 to 275.8 barg) and Type 83: 20 to 2000 psig (1.4 to 137.9 barg).
2. Set pressure range for Type 81P: 50 to 1160 psig (3.5 to 80.0 barg).
3. Set pressure range for Type 81P: 1161 to 6000 psig (80.1 to 413.7 barg).
4. Add 0.90" (23 mm) to 'C max.' dimension for numbered orifice Type 81, 83 and 81P with packed lift lever option.

ANDERSON GREENWOOD DIRECT SPRING OPERATED PRESSURE RELIEF VALVES

DIMENSIONS AND WEIGHTS - SERIES 80

TYPES 81, 83 AND 81P WELDNECK FLANGE CONNECTIONS FOR -4 ORIFICE SRVS, CS AND SS BODY MATERIAL - CONTINUED

Valve size		Dimensions		ANSI inlet flange						ANSI outlet flange		
in (DN)	Set pressure range			150#	300#	600#	900#	1500#	2500#			
1 x 1 (25 x 25)	20 to 4000 psig (1.4 to 275.8 barg) ^{[1][2]}	A	in	5.76	5.94	6.16	6.76	6.76	7.13	150#		
			(mm)	(146.3)	(150.9)	(156.5)	(171.7)	(171.7)	(181.1)			
			B	in	4.06	4.06	4.06	4.06	4.06		4.06	
		B	(mm)	(103.1)	(103.1)	(103.1)	(103.1)	(103.1)	(103.1)			
			C max.	in	13.06	13.25	13.46	14.06	14.06		14.44	
		C max.	(mm)	(331.7)	(336.6)	(341.9)	(357.1)	(357.1)	(366.8)			
			Wt.	lb	13.00	14.00	14.00	19.00	19.00		22.00	
		Wt.	(kg)	(5.9)	(6.4)	(6.4)	(8.6)	(8.6)	(10.0)			
			A	in	----	5.94	6.16	6.76	6.76		7.13	300#
		(mm)		----	(150.9)	(156.5)	(171.7)	(171.7)	(181.1)			
		B		in	----	4.31	4.31	4.31	4.31		4.31	
		B	(mm)	----	(109.5)	(109.5)	(109.5)	(109.5)	(109.5)			
			C max.	in	----	13.25	13.46	14.06	14.06		14.44	
		C max.	(mm)	----	(336.6)	(341.9)	(357.1)	(357.1)	(366.8)			
			Wt.	lb	----	16.00	16.00	20.00	20.00		23.00	
		Wt.	(kg)	----	(7.3)	(7.3)	(9.1)	(9.1)	(10.4)			
			A	in	----	----	6.16	6.76	6.76		7.13	
		(mm)		----	----	(156.5)	(171.7)	(171.7)	(181.1)			
B	in	----		----	4.56	4.56	4.56	4.56				
B	(mm)	----	----	(115.8)	(115.8)	(115.8)	(115.8)					
	C max.	in	----	----	13.46	14.06	14.06	14.44				
C max.	(mm)	----	----	(341.9)	(357.1)	(357.1)	(366.8)					
	Wt.	lb	----	----	16.00	20.00	20.00	23.00				
Wt.	(kg)	----	----	(7.3)	(9.1)	(9.1)	(10.4)					
	A	in	----	----	----	----	----	7.13	900#			
(mm)		----	----	----	----	----	(181.1)					
B		in	----	----	----	----	----	5.00				
B	(mm)	----	----	----	----	----	(127.0)					
	C max.	in	----	----	----	----	14.44					
C max.	(mm)	----	----	----	----	----	(366.8)					
	Wt.	lb	----	----	----	----	28.00					
Wt.	(kg)	----	----	----	----	----	(12.7)					

NOTES

1. Normal set pressure range for Type 81: 100 to 4000 psig (6.9 to 275.8 barg) and Type 83: 20 to 2000 psig (1.4 to 137.9 barg).
2. Set pressure range for Type 81P: 50 to 1160 psig (3.5 to 80.0 barg).
3. Set pressure range for Type 81P: 1161 to 6000 psig (80.1 to 413.7 barg).
4. Add 0.90" (23 mm) to 'C max.' dimension for numbered orifice Type 81, 83 and 81P with packed lift lever option.

ANDERSON GREENWOOD DIRECT SPRING OPERATED PRESSURE RELIEF VALVES

DIMENSIONS AND WEIGHTS - SERIES 80

TYPES 81, 83 AND 81P WELDNECK FLANGE CONNECTIONS FOR -4 ORIFICE SRVS, CS AND SS BODY MATERIAL - CONTINUED

Valve size in (DN)	Set pressure range	Dimensions		ANSI inlet flange						ANSI outlet flange
				150#	300#	600#	900#	1500#	2500#	
1 x 1 (25 x 25)	4001 to 6000 psig (275.9 to 413.7 barg) ^[3]	A	in	----	----	----	----	----	7.13	150#
			(mm)	----	----	----	----	(181.1)		
			B	in	----	----	----	----	4.06	
				(mm)	----	----	----	----	(103.1)	
			C max.	in	----	----	----	----	17.63	
				(mm)	----	----	----	----	(447.8)	
		Wt.	lb	----	----	----	----	27.00		
			(kg)	----	----	----	----	(12.2)		
		A	in	----	----	----	----	7.13	300#	
			(mm)	----	----	----	----	(181.1)		
			B	in	----	----	----	----		4.31
				(mm)	----	----	----	----		(109.5)
			C max.	in	----	----	----	----		17.63
				(mm)	----	----	----	----		(447.8)
		Wt.	lb	----	----	----	----	29.00		
			(kg)	----	----	----	----	(13.2)		
		A	in	----	----	----	----	7.13	600#	
			(mm)	----	----	----	----	(181.1)		
B	in		----	----	----	----	4.56			
	(mm)		----	----	----	----	(115.8)			
C max.	in		----	----	----	----	17.63			
	(mm)		----	----	----	----	(447.8)			
Wt.	lb	----	----	----	----	29.00				
	(kg)	----	----	----	----	(13.2)				
A	in	----	----	----	----	7.13	900#			
	(mm)	----	----	----	----	(181.1)				
	B	in	----	----	----	----		5.00		
		(mm)	----	----	----	----		(127.0)		
	C max.	in	----	----	----	----		17.63		
		(mm)	----	----	----	----		(447.8)		
Wt.	lb	----	----	----	----	33.00				
	(kg)	----	----	----	----	(15.0)				

NOTES

1. Normal set pressure range for Type 81: 100 to 4000 psig (6.9 to 275.8 barg) and Type 83: 20 to 2000 psig (1.4 to 137.9 barg).
2. Set pressure range for Type 81P: 50 to 1160 psig (3.5 to 80.0 barg).
3. Set pressure range for Type 81P: 1161 to 6000 psig (80.1 to 413.7 barg).
4. Add 0.90" (23 mm) to 'C max.' dimension for numbered orifice Type 81, 83 and 81P with packed lift lever option.

ANDERSON GREENWOOD DIRECT SPRING OPERATED PRESSURE RELIEF VALVES

DIMENSIONS AND WEIGHTS - SERIES 80

TYPES 81 AND 83 WELDNECK FLANGE CONNECTIONS FOR -6 (D) ORIFICE SRVS, CS AND SS BODY MATERIAL

Valve size		Dimensions		ANSI inlet flange						ANSI outlet flange	
in (DN)	Set pressure range			150#	300#	600#	900#	1500#	2500#		
½ x 1 (15 x 25)	20 to 1410 psig (1.4 to 97.2 barg) ^[1]	A	in	5.51	5.70	5.94	5.66	5.66	6.18	150#	
			(mm)	(139.9)	(144.8)	(150.9)	(143.7)	(143.7)	(156.9)		
		B	in	4.06	4.06	4.06	4.06	4.06	4.06		
			(mm)	(103.1)	(103.1)	(103.1)	(103.1)	(103.1)	(103.1)		
		C max.	in	12.80	13.00	13.25	12.96	12.96	13.50		
			(mm)	(325.1)	(330.2)	(336.6)	(329.2)	(329.2)	(342.9)		
	Wt.	lb	13.00	13.00	14.00	18.00	18.00	19.00			
		(kg)	(5.9)	(5.9)	(6.4)	(8.2)	(8.2)	(8.6)			
			A	in	----	5.70	5.94	5.66	5.66	6.18	300#
				(mm)	----	(144.8)	(150.9)	(143.7)	(143.7)	(156.9)	
			B	in	----	4.31	4.31	4.31	4.31	4.31	
				(mm)	----	(109.5)	(109.5)	(109.5)	(109.5)	(109.5)	
C max.			in	----	13.00	13.25	12.96	12.96	13.50		
			(mm)	----	(330.2)	(336.6)	(329.2)	(329.2)	(342.9)		
Wt.		lb	----	14.00	15.00	19.00	19.00	20.00			
		(kg)	----	(6.4)	(6.8)	(8.6)	(8.6)	(9.1)			
			A	in	----	----	5.94	5.66	5.66	6.18	600#
				(mm)	----	----	(150.9)	(143.7)	(143.7)	(156.9)	
			B	in	----	----	4.56	4.56	4.56	4.56	
				(mm)	----	----	(115.8)	(115.8)	(115.8)	(115.8)	
	C max.		in	----	----	13.25	12.96	12.96	13.50		
			(mm)	----	----	(336.6)	(329.2)	(329.2)	(342.9)		
	Wt.	lb	----	----	15.00	19.00	19.00	20.00			
		(kg)	----	----	(6.8)	(8.6)	(8.6)	(9.1)			
			A	in	----	----	----	----	6.18	900#	
				(mm)	----	----	----	----	(156.9)		
			B	in	----	----	----	----	5.00		
				(mm)	----	----	----	----	(127.0)		
C max.			in	----	----	----	----	13.50			
			(mm)	----	----	----	----	(342.9)			
Wt.		lb	----	----	----	----	25.0				
		(kg)	----	----	----	----	(11.3)				

NOTES

- Normal set pressure range for Type 81: 100 to 4000 psig (6.9 to 275.8 barg) and Type 83: 20 to 2000 psig (1.3 to 137.8 barg).
- Add 0.90" (23 mm) to 'C max.' dimension for numbered orifice Types 81, 83 and 81P with packed lift lever option.

ANDERSON GREENWOOD DIRECT SPRING OPERATED PRESSURE RELIEF VALVES

DIMENSIONS AND WEIGHTS - SERIES 80

TYPES 81 AND 83 WELDNECK FLANGE CONNECTIONS FOR -6 (D) ORIFICE SRVS, CS AND SS BODY MATERIAL - CONTINUED

Valve size in (DN)	Set pressure range	Dimensions		ANSI inlet flange						ANSI outlet flange			
				150#	300#	600#	900#	1500#	2500#				
½ x 1 (15 x 25)	1411 to 6000 psig (97.3 to 413.7 barg)	A	in	----	----	5.94	5.66	5.66	6.18	150#			
			(mm)	----	----	(150.9)	(143.7)	(143.7)	(156.9)				
		B	in	----	----	4.06	4.06	4.06	4.06				
			(mm)	----	----	(103.1)	(103.1)	(103.1)	(103.1)				
		C max.	in	----	----	16.44	16.16	16.16	16.68				
			(mm)	----	----	(417.6)	(410.5)	(410.5)	(423.7)				
		Wt.	lb	----	----	19.00	23.00	23.00	24.00				
			(kg)	----	----	(8.6)	(10.4)	(10.4)	(10.9)				
				A	in	----	----	5.94	5.66		5.66	6.18	300#
					(mm)	----	----	(150.9)	(143.7)		(143.7)	(156.9)	
				B	in	----	----	4.31	4.31		4.31	4.31	
					(mm)	----	----	(109.5)	(109.5)		(109.5)	(109.5)	
C max.	in			----	----	16.44	16.16	16.16	16.68				
	(mm)			----	----	(417.6)	(410.5)	(410.5)	(423.7)				
Wt.	lb			----	----	21.00	25.00	25.00	26.00				
	(kg)			----	----	(9.5)	(11.3)	(11.3)	(11.8)				
				A	in	----	----	5.94	5.66	5.66	6.18	600#	
					(mm)	----	----	(150.9)	(143.7)	(143.7)	(156.9)		
				B	in	----	----	4.56	4.56	4.56	4.56		
					(mm)	----	----	(115.8)	(115.8)	(115.8)	(115.8)		
		C max.	in	----	----	16.44	16.16	16.16	16.68				
			(mm)	----	----	(417.6)	(410.5)	(410.5)	(423.7)				
		Wt.	lb	----	----	21.00	25.00	25.00	26.00				
			(kg)	----	----	(9.5)	(11.3)	(11.3)	(11.8)				
				A	in	----	----	----	----	----	6.18		900#
					(mm)	----	----	----	----	----	(156.9)		
				B	in	----	----	----	----	----	5.00		
					(mm)	----	----	----	----	----	(127.0)		
C max.	in			----	----	----	----	----	16.68				
	(mm)			----	----	----	----	----	(423.7)				
Wt.	lb			----	----	----	----	----	30.00				
	(kg)			----	----	----	----	----	(13.6)				

NOTES

1. Normal set pressure range for Type 81: 100 to 4000 psig (6.9 to 275.8 barg) and Type 83: 20 to 2000 psig (1.3 to 137.8 barg).
2. Add 0.90" (23 mm) to 'C max.' dimension for numbered orifice Types 81, 83 and 81P with packed lift lever option.

ANDERSON GREENWOOD DIRECT SPRING OPERATED PRESSURE RELIEF VALVES

DIMENSIONS AND WEIGHTS - SERIES 80

TYPES 81 AND 83 WELDNECK FLANGE CONNECTIONS FOR -6 (D) ORIFICE SRVS, CS AND SS BODY MATERIAL - CONTINUED

Valve size in (DN)	Set pressure range	Dimensions		ANSI inlet flange						ANSI outlet flange			
				150#	300#	600#	900#	1500#	2500#				
¾ x 1 (20 x 25)	20 to 1410 psig (1.4 to 97.2 barg) ^[1]	A	in	5.70	5.88	6.13	6.63	6.63	7.00	150#			
			(mm)	(144.8)	(149.4)	(150.9)	(168.4)	(168.4)	(177.8)				
		B	in	4.06	4.06	4.06	4.06	4.06	4.06				
			(mm)	(103.1)	(103.1)	(103.1)	(103.1)	(103.1)	(103.1)				
		C max.	in	13.00	13.18	13.44	13.94	13.94	14.30				
			(mm)	(330.2)	(334.8)	(341.4)	(354.1)	(354.1)	(363.2)				
		Wt.	lb	13.00	14.00	14.00	18.00	18.00	20.00				
			(kg)	(5.9)	(6.4)	(6.4)	(8.2)	(8.2)	(9.1)				
				A	in	----	5.88	6.13	6.63		6.63	7.00	300#
					(mm)	----	(149.4)	(150.9)	(168.4)		(168.4)	(177.8)	
				B	in	----	4.31	4.31	4.31		4.31	4.31	
					(mm)	----	(109.5)	(109.5)	(109.5)		(109.5)	(109.5)	
C max.	in			----	13.18	13.44	13.94	13.94	14.30				
	(mm)			----	(334.8)	(341.4)	(354.1)	(354.1)	(363.2)				
Wt.	lb			----	15.00	16.00	19.00	19.00	21.00				
	(kg)			----	(6.8)	(7.3)	(8.6)	(8.6)	(9.5)				
				A	in	----	----	6.13	6.63	6.63	7.00	600#	
					(mm)	----	----	(150.9)	(168.4)	(168.4)	(177.8)		
				B	in	----	----	4.56	4.56	4.56	4.56		
					(mm)	----	----	(115.8)	(115.8)	(115.8)	(115.8)		
		C max.	in	----	----	13.44	13.94	13.94	14.30				
			(mm)	----	----	(336.6)	(354.1)	(354.1)	(363.2)				
		Wt.	lb	----	----	16.00	19.00	19.00	21.00				
			(kg)	----	----	(7.3)	(8.6)	(8.6)	(9.5)				
				A	in	----	----	----	----	7.00	900#		
					(mm)	----	----	----	----	(156.9)			
				B	in	----	----	----	----	5.00			
					(mm)	----	----	----	----	(127.0)			
C max.	in			----	----	----	----	14.30					
	(mm)			----	----	----	----	(342.9)					
Wt.	lb			----	----	----	----	26.00					
	(kg)			----	----	----	----	(11.8)					

NOTES

- Normal set pressure range for Type 81: 100 to 4000 psig (6.9 to 275.8 barg) and Type 83: 20 to 2000 psig (1.3 to 137.8 barg).
- Add 0.90" (23 mm) to 'C max.' dimension for numbered orifice Types 81, 83 and 81P with packed lift lever option.

ANDERSON GREENWOOD DIRECT SPRING OPERATED PRESSURE RELIEF VALVES

DIMENSIONS AND WEIGHTS - SERIES 80

TYPES 81 AND 83 WELDNECK FLANGE CONNECTIONS FOR -6 (D) ORIFICE SRVS, CS AND SS BODY MATERIAL - CONTINUED

Valve size in (DN)	Set pressure range	Dimensions		ANSI inlet flange						ANSI outlet flange		
				150#	300#	600#	900#	1500#	2500#			
¾ x 1 (15 x 25)	1411 to 6000 psig (97.3 to 413.7 barg)	A	in	----	----	6.13	6.63	6.63	7.00	150#		
			(mm)	----	----	(150.9)	(168.4)	(168.4)	(177.8)			
		B	in	----	----	4.06	4.06	4.06	4.06			
			(mm)	----	----	(103.1)	(103.1)	(103.1)	(103.1)			
		C max.	in	----	----	16.63	17.13	17.13	17.50			
			(mm)	----	----	(422.4)	(435.1)	(435.1)	(444.5)			
		Wt.	lb	----	----	20.00	23.00	23.00	25.00			
			(kg)	----	----	(9.1)	(10.4)	(10.4)	(11.3)			
				A	in	----	----	6.13	6.63	6.63	7.00	300#
					(mm)	----	----	(150.9)	(168.4)	(168.4)	(177.8)	
				B	in	----	----	4.31	4.31	4.31	4.31	
					(mm)	----	----	(109.5)	(109.5)	(109.5)	(109.5)	
C max.	in			----	----	16.63	17.13	17.13	17.50			
	(mm)			----	----	(422.4)	(435.1)	(435.1)	(444.5)			
Wt.	lb			----	----	21.00	25.00	25.00	27.00			
	(kg)			----	----	(9.5)	(11.3)	(11.3)	(12.2)			
				A	in	----	----	6.13	6.63	6.63	7.00	600#
					(mm)	----	----	(150.9)	(168.4)	(168.4)	(177.8)	
				B	in	----	----	4.56	4.56	4.56	4.56	
					(mm)	----	----	(115.8)	(115.8)	(115.8)	(115.8)	
		C max.	in	----	----	16.63	17.13	17.13	17.50			
			(mm)	----	----	(422.4)	(435.1)	(435.1)	(444.5)			
		Wt.	lb	----	----	21.00	25.00	25.00	27.00			
			(kg)	----	----	(9.5)	(11.3)	(11.3)	(12.2)			
				A	in	----	----	----	----	----	7.00	900#
					(mm)	----	----	----	----	----	(177.8)	
				B	in	----	----	----	----	----	5.00	
					(mm)	----	----	----	----	----	(127.0)	
C max.	in			----	----	----	----	----	17.50			
	(mm)			----	----	----	----	----	(444.5)			
Wt.	lb			----	----	----	----	----	31.00			
	(kg)			----	----	----	----	----	(14.1)			

NOTES

1. Normal set pressure range for Type 81: 100 to 4000 psig (6.9 to 275.8 barg) and Type 83: 20 to 2000 psig (1.3 to 137.8 barg).
2. Add 0.90" (23 mm) to 'C max.' dimension for numbered orifice Types 81, 83 and 81P with packed lift lever option.

ANDERSON GREENWOOD DIRECT SPRING OPERATED PRESSURE RELIEF VALVES

DIMENSIONS AND WEIGHTS - SERIES 80

TYPES 81 AND 83 WELDNECK FLANGE CONNECTIONS FOR -6 (D) ORIFICE SRVS, CS AND SS BODY MATERIAL - CONTINUED

Valve size in (DN)	Set pressure range	Dimensions		ANSI inlet flange						ANSI outlet flange			
				150#	300#	600#	900#	1500#	2500#				
1 x 1 (25 x 25)	20 to 1410 psig (1.4 to 97.2 barg) ^[1]	A	in	5.76	5.94	6.16	6.76	6.76	7.13	150#			
			(mm)	(146.3)	(150.9)	(156.5)	(171.7)	(171.7)	(181.1)				
		B	in	4.06	4.06	4.06	4.06	4.06	4.06				
			(mm)	(103.1)	(103.1)	(103.1)	(103.1)	(103.1)	(103.1)				
		C max.	in	13.06	13.25	13.46	14.06	14.06	14.44				
			(mm)	(331.7)	(336.6)	(341.9)	(357.1)	(357.1)	(366.8)				
		Wt.	lb	13.00	14.00	14.00	19.00	19.00	22.00				
			(kg)	(5.9)	(6.4)	(6.4)	(8.6)	(8.6)	(10.0)				
				A	in	----	5.94	6.16	6.76		6.76	7.13	300#
					(mm)	----	(150.9)	(156.5)	(171.7)		(171.7)	(181.1)	
				B	in	----	4.31	4.31	4.31		4.31	4.31	
					(mm)	----	(109.5)	(109.5)	(109.5)		(109.5)	(109.5)	
C max.	in			----	13.25	13.46	14.06	14.06	14.44				
	(mm)			----	(336.6)	(341.9)	(357.1)	(357.1)	(366.8)				
Wt.	lb			----	16.00	16.00	20.00	20.00	23.00				
	(kg)			----	(7.3)	(7.3)	(9.1)	(9.1)	(10.4)				
				A	in	----	----	6.16	6.76	6.76	7.13	600#	
					(mm)	----	----	(156.5)	(171.7)	(171.7)	(181.1)		
				B	in	----	----	4.56	4.56	4.56	4.56		
					(mm)	----	----	(115.8)	(115.8)	(115.8)	(115.8)		
		C max.	in	----	----	13.46	14.06	14.06	14.44				
			(mm)	----	----	(341.9)	(357.1)	(357.1)	(366.8)				
		Wt.	lb	----	----	16.00	20.00	20.00	23.00				
			(kg)	----	----	(7.3)	(9.1)	(9.1)	(10.4)				
				A	in	----	----	----	----	7.13	900#		
					(mm)	----	----	----	----	(181.1)			
				B	in	----	----	----	----	5.00			
					(mm)	----	----	----	----	(127.0)			
C max.	in			----	----	----	----	14.44					
	(mm)			----	----	----	----	(366.8)					
Wt.	lb			----	----	----	----	28.00					
	(kg)			----	----	----	----	(12.7)					

NOTES

1. Normal set pressure range for Type 81: 100 to 4000 psig (6.9 to 275.8 barg) and Type 83: 20 to 2000 psig (1.3 to 137.8 barg).
2. Add 0.90" (23 mm) to 'C max.' dimension for numbered orifice Types 81, 83 and 81P with packed lift lever option.

ANDERSON GREENWOOD DIRECT SPRING OPERATED PRESSURE RELIEF VALVES

DIMENSIONS AND WEIGHTS - SERIES 80

TYPES 81 AND 83 WELDNECK FLANGE CONNECTIONS FOR -6 (D) ORIFICE SRVS, CS AND SS BODY MATERIAL - CONTINUED

Valve size in (DN)	Set pressure range	Dimensions		ANSI inlet flange						ANSI outlet flange			
				150#	300#	600#	900#	1500#	2500#				
1 x 1 (25 x 25)	1411 to 6000 psig (97.3 to 413.7 barg)	A	in	----	----	6.16	6.76	6.76	7.13	150#			
			(mm)	----	----	(156.5)	(171.7)	(171.7)	(181.1)				
		B	in	----	----	4.06	4.06	4.06	4.06				
			(mm)	----	----	(103.1)	(103.1)	(103.1)	(103.1)				
		C max.	in	----	----	16.66	17.26	17.26	17.63				
			(mm)	----	----	(423.2)	(438.4)	(438.4)	(447.8)				
		Wt.	lb	----	----	20.00	24.00	24.00	27.00				
			(kg)	----	----	(9.1)	(10.9)	(10.9)	(12.2)				
				A	in	----	----	6.16	6.76		6.76	7.13	300#
					(mm)	----	----	(156.5)	(171.7)		(171.7)	(181.1)	
				B	in	----	----	4.31	4.31		4.31	4.31	
					(mm)	----	----	(109.5)	(109.5)		(109.5)	(109.5)	
C max.	in			----	----	16.66	17.26	17.26	17.63				
	(mm)			----	----	(423.2)	(438.4)	(438.4)	(447.8)				
Wt.	lb			----	----	21.00	26.00	26.00	29.00				
	(kg)			----	----	(9.5)	(11.8)	(11.8)	(13.2)				
				A	in	----	----	6.16	6.76	6.76	7.13	600#	
					(mm)	----	----	(156.5)	(171.7)	(171.7)	(181.1)		
				B	in	----	----	4.56	4.56	4.56	4.56		
					(mm)	----	----	(115.8)	(115.8)	(115.8)	(115.8)		
		C max.	in	----	----	16.66	17.26	17.26	17.63				
			(mm)	----	----	(423.2)	(438.4)	(438.4)	(447.8)				
		Wt.	lb	----	----	21.00	26.00	26.00	29.00				
			(kg)	----	----	(9.5)	(11.8)	(11.8)	(13.2)				
				A	in	----	----	----	----	----	7.13		900#
					(mm)	----	----	----	----	----	(181.1)		
				B	in	----	----	----	----	----	5.00		
					(mm)	----	----	----	----	----	(127.0)		
C max.	in			----	----	----	----	----	17.63				
	(mm)			----	----	----	----	----	(447.8)				
Wt.	lb			----	----	----	----	----	30.00				
	(kg)			----	----	----	----	----	(15.0)				

NOTES

- Normal set pressure range for Type 81: 100 to 4000 psig (6.9 to 275.8 barg) and Type 83: 20 to 2000 psig (1.3 to 137.8 barg).
- Add 0.90" (23 mm) to 'C max.' dimension for numbered orifice Types 81, 83 and 81P with packed lift lever option.

ANDERSON GREENWOOD DIRECT SPRING OPERATED PRESSURE RELIEF VALVES

DIMENSIONS AND WEIGHTS - SERIES 80

TYPES 81, 83 AND 81P WELDNECK FLANGE CONNECTIONS FOR -8 (E) ORIFICE SRVS, CS AND SS BODY MATERIAL

Valve size in (DN)	Set pressure range	Dimensions		ANSI inlet flange						ANSI outlet flange			
				150#	300#	600#	900#	1500#	2500#				
¾ x 1 (20 x 25)	20 to 600 psig (1.4 to 41.4 barg) ^[1]	A	in	5.70	5.88	6.13	6.63	6.63	7.00	150#			
			(mm)	(144.8)	(149.4)	(150.9)	(168.4)	(168.4)	(177.8)				
		B	in	4.06	4.06	4.06	4.06	4.06	4.06				
			(mm)	(103.1)	(103.1)	(103.1)	(103.1)	(103.1)	(103.1)				
		C max.	in	13.00	13.18	13.44	13.94	13.94	14.30				
			(mm)	(330.2)	(334.8)	(341.4)	(354.1)	(354.1)	(363.2)				
		Wt.	lb	13.00	14.00	14.00	18.00	18.00	20.00				
			(kg)	(5.9)	(6.4)	(6.4)	(8.2)	(8.2)	(9.1)				
				A	in	----	5.88	6.13	6.63		6.63	7.00	300#
					(mm)	----	(149.4)	(150.9)	(168.4)		(168.4)	(177.8)	
				B	in	----	4.31	4.31	4.31		4.31	4.31	
					(mm)	----	(109.5)	(109.5)	(109.5)		(109.5)	(109.5)	
C max.	in			----	13.18	13.44	13.94	13.94	14.30				
	(mm)			----	(334.8)	(341.4)	(354.1)	(354.1)	(363.2)				
Wt.	lb			----	15.00	16.00	19.00	19.00	21.00				
	(kg)			----	(6.8)	(7.3)	(8.6)	(8.6)	(9.5)				
				A	in	----	----	6.13	6.63	6.63	7.00	600#	
					(mm)	----	----	(150.9)	(168.4)	(168.4)	(177.8)		
				B	in	----	----	4.56	4.56	4.56	4.56		
					(mm)	----	----	(115.8)	(115.8)	(115.8)	(115.8)		
		C max.	in	----	----	13.44	13.94	13.94	14.30				
			(mm)	----	----	(336.6)	(354.1)	(354.1)	(363.2)				
		Wt.	lb	----	----	16.00	19.00	19.00	21.00				
			(kg)	----	----	(7.3)	(8.6)	(8.6)	(9.5)				
				A	in	----	----	----	----	7.00	900#		
					(mm)	----	----	----	----	(156.9)			
				B	in	----	----	----	----	5.00			
					(mm)	----	----	----	----	(127.0)			
C max.	in			----	----	----	----	14.30					
	(mm)			----	----	----	----	(342.9)					
Wt.	lb			----	----	----	----	26.00					
	(kg)			----	----	----	----	(11.8)					

NOTES

1. Normal set pressure range for Type 81: 100 to 4000 psig (6.9 to 275.8 barg) and Type 83: 20 to 2000 psig (1.3 to 137.8 barg).
2. Add 0.90" (23 mm) to 'C max.' dimension for numbered orifice Types 81, 83 and 81P with packed lift lever option.

ANDERSON GREENWOOD DIRECT SPRING OPERATED PRESSURE RELIEF VALVES

DIMENSIONS AND WEIGHTS - SERIES 80

TYPES 81, 83 AND 81P WELDNECK FLANGE CONNECTIONS FOR -8 (E) ORIFICE SRVS, CS AND SS BODY MATERIAL - CONTINUED

Valve size			ANSI inlet flange							ANSI outlet flange		
in (DN)	Set pressure range	Dimensions	150#	300#	600#	900#	1500#	2500#				
¾ x 1 (20 x 25)	601 to 4000 psig (41.5 to 276 barg)	A	in	----	5.88	6.13	6.63	6.63	7.00	150#		
			(mm)	----	(149.4)	(150.9)	(168.4)	(168.4)	(177.8)			
		B	in	----	4.06	4.06	4.06	4.06	4.06			
			(mm)	----	(103.1)	(103.1)	(103.1)	(103.1)	(103.1)			
		C max.	in	----	16.38	16.63	17.13	17.13	17.50			
			(mm)	----	(416.1)	(422.4)	(435.1)	(435.1)	(444.5)			
		Wt.	lb	----	19.00	20.00	23.00	23.00	25.00			
			(kg)	----	(8.6)	(9.1)	(10.4)	(10.4)	(11.3)			
		A	in	----	5.88	6.13	6.63	6.63	7.00		300#	
			(mm)	----	(149.4)	(150.9)	(168.4)	(168.4)	(177.8)			
		B	in	----	4.31	4.31	4.31	4.31	4.31			
			(mm)	----	(109.5)	(109.5)	(109.5)	(109.5)	(109.5)			
		C max.	in	----	16.38	16.63	17.13	17.13	17.50			
			(mm)	----	(416.1)	(422.4)	(435.1)	(435.1)	(444.5)			
		Wt.	lb	----	21.00	21.00	25.00	25.00	27.00			
			(kg)	----	(9.5)	(9.5)	(11.3)	(11.3)	(12.2)			
		A	in	----	----	6.13	6.63	6.63	7.00			600#
			(mm)	----	----	(150.9)	(168.4)	(168.4)	(177.8)			
B	in	----	----	4.56	4.56	4.56	4.56					
	(mm)	----	----	(115.8)	(115.8)	(115.8)	(115.8)					
C max.	in	----	----	16.63	17.13	17.13	17.50					
	(mm)	----	----	(422.4)	(435.1)	(435.1)	(444.5)					
Wt.	lb	----	----	21.00	25.00	25.00	27.00					
	(kg)	----	----	(9.5)	(11.3)	(11.3)	(12.2)					
A	in	----	----	----	----	7.00	900#					
	(mm)	----	----	----	----	(156.9)						
B	in	----	----	----	----	5.00						
	(mm)	----	----	----	----	(127.0)						
C max.	in	----	----	----	----	17.50						
	(mm)	----	----	----	----	(444.5)						
Wt.	lb	----	----	----	----	31.00						
	(kg)	----	----	----	----	(14.1)						

NOTES

- Normal set pressure range for Type 81: 100 to 4000 psig (6.9 to 275.8 barg) and Type 83: 20 to 2000 psig (1.3 to 137.8 barg).
- Add 0.90" (23 mm) to 'C max.' dimension for numbered orifice Types 81, 83 and 81P with packed lift lever option.

ANDERSON GREENWOOD DIRECT SPRING OPERATED PRESSURE RELIEF VALVES

DIMENSIONS AND WEIGHTS - SERIES 80

TYPES 81, 83 AND 81P WELDNECK FLANGE CONNECTIONS FOR -8 (E) ORIFICE SRVS, CS AND SS BODY MATERIAL - CONTINUED

Valve size in (DN)	Set pressure range	Dimensions		ANSI inlet flange						ANSI outlet flange			
				150#	300#	600#	900#	1500#	2500#				
1 x 1 (25 x 25)	20 to 600 psig (1.4 to 41.4 barg) ^[1]	A	in	5.76	5.94	6.16	6.76	6.76	7.13	150#			
			(mm)	(146.3)	(150.9)	(156.5)	(171.7)	(171.7)	(181.1)				
		B	in	4.06	4.06	4.06	4.06	4.06	4.06				
			(mm)	(103.1)	(103.1)	(103.1)	(103.1)	(103.1)	(103.1)				
		C max.	in	13.06	13.25	13.46	14.06	14.06	14.44				
			(mm)	(331.7)	(336.6)	(341.9)	(357.1)	(357.1)	(366.8)				
		Wt.	lb	13.00	14.00	14.00	19.00	19.00	22.00				
			(kg)	(5.9)	(6.4)	(6.4)	(8.6)	(8.6)	(10.0)				
				A	in	----	5.94	6.16	6.76		6.76	7.13	300#
					(mm)	----	(150.9)	(156.5)	(171.7)		(171.7)	(181.1)	
				B	in	----	4.31	4.31	4.31		4.31	4.31	
					(mm)	----	(109.5)	(109.5)	(109.5)		(109.5)	(109.5)	
C max.	in			----	13.25	13.46	14.06	14.06	14.44				
	(mm)			----	(336.6)	(341.9)	(357.1)	(357.1)	(366.8)				
Wt.	lb			----	16.00	16.00	20.00	20.00	23.00				
	(kg)			----	(7.3)	(7.3)	(9.1)	(9.1)	(10.4)				
				A	in	----	----	6.16	6.76	6.76	7.13	600#	
					(mm)	----	----	(156.5)	(171.7)	(171.7)	(181.1)		
				B	in	----	----	4.56	4.56	4.56	4.56		
					(mm)	----	----	(115.8)	(115.8)	(115.8)	(115.8)		
		C max.	in	----	----	13.46	14.06	14.06	14.44				
			(mm)	----	----	(341.9)	(357.1)	(357.1)	(366.8)				
		Wt.	lb	----	----	16.00	20.00	20.00	23.00				
			(kg)	----	----	(7.3)	(9.1)	(9.1)	(10.4)				
				A	in	----	----	----	----	7.13	900#		
					(mm)	----	----	----	----	(181.1)			
				B	in	----	----	----	----	5.00			
					(mm)	----	----	----	----	(127.0)			
C max.	in			----	----	----	----	14.44					
	(mm)			----	----	----	----	(366.8)					
Wt.	lb			----	----	----	----	28.00					
	(kg)			----	----	----	----	(12.7)					

NOTES

1. Normal set pressure range for Type 81: 100 to 4000 psig (6.9 to 275.8 barg) and Type 83: 20 to 2000 psig (1.3 to 137.8 barg).
2. Add 0.90" (23 mm) to 'C max.' dimension for numbered orifice Types 81, 83 and 81P with packed lift lever option.

ANDERSON GREENWOOD DIRECT SPRING OPERATED PRESSURE RELIEF VALVES

DIMENSIONS AND WEIGHTS - SERIES 80

TYPES 81, 83 AND 81P WELDNECK FLANGE CONNECTIONS FOR -8 (E) ORIFICE SRVS, CS AND SS BODY MATERIAL - CONTINUED

Valve size		Dimensions		ANSI inlet flange						ANSI outlet flange	
in (DN)	Set pressure range			150#	300#	600#	900#	1500#	2500#		
1 x 1 (25 x 25)	601 to 4000 psig (41.5 to 276 barg)	A	in	----	5.94	6.16	6.76	6.76	7.13	150#	
			(mm)	----	(150.9)	(156.5)	(171.7)	(171.7)	(181.1)		
		B	in	----	4.06	4.06	4.06	4.06	4.06		
			(mm)	----	(103.1)	(103.1)	(103.1)	(103.1)	(103.1)		
		C max.	in	----	16.44	16.66	17.26	17.26	17.63		
			(mm)	----	(417.6)	(423.2)	(438.4)	(438.4)	(447.8)		
	Wt.	lb	----	20.00	20.00	24.00	24.00	27.00			
		(kg)	----	(9.1)	(9.1)	(10.9)	(10.9)	(12.2)			
			A	in	----	5.94	6.16	6.76	6.76	7.13	300#
				(mm)	----	(150.9)	(156.5)	(171.7)	(171.7)	(181.1)	
			B	in	----	4.31	4.31	4.31	4.31	4.31	
				(mm)	----	(109.5)	(109.5)	(109.5)	(109.5)	(109.5)	
C max.			in	----	16.44	16.66	17.26	17.26	17.63		
			(mm)	----	(417.6)	(423.2)	(438.4)	(438.4)	(447.8)		
Wt.		lb	----	21.00	21.00	26.00	26.00	29.00			
		(kg)	----	(9.5)	(9.5)	(11.8)	(11.8)	(13.2)			
			A	in	----	----	6.16	6.76	6.76	7.13	600#
				(mm)	----	----	(156.5)	(171.7)	(171.7)	(181.1)	
			B	in	----	----	4.56	4.56	4.56	4.56	
				(mm)	----	----	(115.8)	(115.8)	(115.8)	(115.8)	
	C max.		in	----	----	16.66	17.26	17.26	17.63		
			(mm)	----	----	(423.2)	(438.4)	(438.4)	(447.8)		
	Wt.	lb	----	----	21.00	26.00	26.00	29.00			
		(kg)	----	----	(9.5)	(11.8)	(11.8)	(13.2)			
			A	in	----	----	----	----	7.13	900#	
				(mm)	----	----	----	----	(181.1)		
			B	in	----	----	----	----	5.00		
				(mm)	----	----	----	----	(127.0)		
C max.			in	----	----	----	----	17.63			
			(mm)	----	----	----	----	(447.8)			
Wt.		lb	----	----	----	----	33.00				
		(kg)	----	----	----	----	(15.0)				

NOTES

1. Normal set pressure range for Type 81: 100 to 4000 psig (6.9 to 275.8 barg) and Type 83: 20 to 2000 psig (1.3 to 137.8 barg).
2. Add 0.90" (23 mm) to 'C max.' dimension for numbered orifice Types 81, 83 and 81P with packed lift lever option.

ANDERSON GREENWOOD DIRECT SPRING OPERATED PRESSURE RELIEF VALVES

DIMENSIONS AND WEIGHTS - SERIES 80

TYPES 81, 83 AND 81P WELDNECK FLANGE CONNECTIONS FOR -8 (E) ORIFICE SRVS, CS AND SS BODY MATERIAL - CONTINUED

Valve size		Dimensions		ANSI inlet flange						ANSI outlet flange					
in (DN)	Set pressure range			150#	300#	600#	900#	1500#	2500#						
1 x 2 (25 x 50)	20 to 600 psig (1.4 to 41.4 barg) ^[1]	A	in	5.76	5.94	6.16	6.76	6.76	7.13	150#					
			(mm)	(146.3)	(150.9)	(156.5)	(171.7)	(171.7)	(181.1)						
		B	in	4.25	4.25	4.25	4.25	4.25	4.25		300#				
			(mm)	(108.0)	(108.0)	(108.0)	(108.0)	(108.0)	(108.0)						
		C max.	in	13.06	13.25	13.46	14.06	14.06	14.44			600#			
			(mm)	(331.7)	(336.6)	(341.9)	(357.1)	(357.1)	(366.8)						
		Wt.	lb	14.00	15.00	16.00	20.00	20.00	23.00				900#		
			(kg)	(6.4)	(6.8)	(7.3)	(9.1)	(9.1)	(10.4)						
		A	in	-----	5.94	6.16	6.76	6.76	7.13					300#	
			(mm)	-----	(150.9)	(156.5)	(171.7)	(171.7)	(181.1)						
		B	in	-----	4.50	4.50	4.50	4.50	4.50						600#
			(mm)	-----	(114.3)	(114.3)	(114.3)	(114.3)	(114.3)						
C max.	in	-----	13.25	13.46	14.06	14.06	14.44	900#							
	(mm)	-----	(336.6)	(341.9)	(357.1)	(357.1)	(366.8)								
Wt.	lb	-----	18.00	18.00	22.00	22.00	25.00		150#						
	(kg)	-----	(8.2)	(8.2)	(10.0)	(10.0)	(11.3)								
A	in	-----	-----	6.16	6.76	6.76	7.13			300#					
	(mm)	-----	-----	(156.5)	(171.7)	(171.7)	(181.1)								
B	in	-----	-----	4.87	4.87	4.87	4.87				600#				
	(mm)	-----	-----	(123.7)	(123.7)	(123.7)	(123.7)								
C max.	in	-----	-----	13.46	14.06	14.06	14.44					900#			
	(mm)	-----	-----	(341.9)	(357.1)	(357.1)	(366.8)								
Wt.	lb	-----	-----	19.00	23.00	23.00	26.00						150#		
	(kg)	-----	-----	(8.6)	(10.4)	(10.4)	(11.8)								
A	in	-----	-----	-----	-----	-----	7.13	900#							
	(mm)	-----	-----	-----	-----	-----	(181.1)								
B	in	-----	-----	-----	-----	-----	5.37		150#						
	(mm)	-----	-----	-----	-----	-----	(127.0)								
C max.	in	-----	-----	-----	-----	-----	14.44			300#					
	(mm)	-----	-----	-----	-----	-----	(366.8)								
Wt.	lb	-----	-----	-----	-----	-----	34.00				600#				
	(kg)	-----	-----	-----	-----	-----	(15.4)								

NOTES

1. Normal set pressure range for Type 81: 100 to 4000 psig (6.9 to 275.8 barg) and Type 83: 20 to 2000 psig (1.3 to 137.8 barg).
2. Add 0.90" (23 mm) to 'C max.' dimension for numbered orifice Types 81, 83 and 81P with packed lift lever option.

ANDERSON GREENWOOD DIRECT SPRING OPERATED PRESSURE RELIEF VALVES

DIMENSIONS AND WEIGHTS - SERIES 80

TYPES 81, 83 AND 81P WELDNECK FLANGE CONNECTIONS FOR -8 (E) ORIFICE SRVS, CS AND SS BODY MATERIAL - CONTINUED

Valve size			ANSI inlet flange							ANSI outlet flange						
in (DN)	Set pressure range	Dimensions	150#	300#	600#	900#	1500#	2500#								
1 x 2 (25 x 50)	601 to 4000 psig (41.5 to 276 barg)	A	in	----	5.94	6.16	6.76	6.76	7.13	150#						
			(mm)	----	(150.9)	(156.5)	(171.7)	(171.7)	(181.1)							
		B	in	----	4.25	4.25	4.25	4.25	4.25							
			(mm)	----	(108.0)	(108.0)	(108.0)	(108.0)	(108.0)							
		C max.	in	----	16.44	16.66	17.26	17.26	17.63							
			(mm)	----	(417.6)	(423.2)	(438.4)	(438.4)	(447.8)							
		Wt.	lb	----	21.00	21.00	25.00	25.00	28.00							
			(kg)	----	(9.5)	(9.5)	(11.3)	(11.3)	(12.7)							
				A	in	----	5.94	6.16	6.76		6.76	7.13	300#			
					(mm)	----	(150.9)	(156.5)	(171.7)		(171.7)	(181.1)				
				B	in	----	4.50	4.50	4.50		4.50	4.50				
					(mm)	----	(114.3)	(114.3)	(114.3)		(114.3)	(114.3)				
				C max.	in	----	16.44	16.66	17.26		17.26	17.63				
					(mm)	----	(417.6)	(423.2)	(438.4)		(438.4)	(447.8)				
				Wt.	lb	----	23.00	23.00	28.00		28.00	31.00				
					(kg)	----	(10.4)	(10.4)	(12.7)		(12.7)	(14.1)				
						A	in	----	----		6.16	6.76		6.76	7.13	600#
							(mm)	----	----		(156.5)	(171.7)		(171.7)	(181.1)	
B	in					----	----	4.87	4.87	4.87	4.87					
	(mm)					----	----	(123.7)	(123.7)	(123.7)	(123.7)					
C max.	in					----	----	16.66	17.26	17.26	17.63					
	(mm)					----	----	(423.2)	(438.4)	(438.4)	(447.8)					
Wt.	lb					----	----	24.00	29.00	29.00	32.00					
	(kg)					----	----	(10.9)	(13.2)	(13.2)	(14.5)					
						A	in	----	----	----	----	7.13		900#		
							(mm)	----	----	----	----	(181.1)				
		B	in			----	----	----	----	5.37						
			(mm)			----	----	----	----	(127.0)						
		C max.	in			----	----	----	----	17.63						
			(mm)			----	----	----	----	(447.8)						
		Wt.	lb			----	----	----	----	40.00						
			(kg)			----	----	----	----	(18.1)						

NOTES

1. Normal set pressure range for Type 81: 100 to 4000 psig (6.9 to 275.8 barg) and Type 83: 20 to 2000 psig (1.3 to 137.8 barg).
2. Add 0.90" [23 mm] to 'C max.' dimension for numbered orifice Types 81, 83 and 81P with packed lift lever option.

ANDERSON GREENWOOD DIRECT SPRING OPERATED PRESSURE RELIEF VALVES

DIMENSIONS AND WEIGHTS - SERIES 80

DIMENSIONS AND WEIGHTS FOR F ORIFICE

Valve model type	Body material	Valve size			Dimensions			Weight lb (kg)
		Inlet by outlet in (DN)	Inlet	Outlet	A in (mm)	B in (mm)	C max ^[1] in (mm)	
81, 83	Brass, CS, SS	1½ x 2 (40 x 50)	FNPT	FNPT	3.41 (87)	3.50 (89)	20.00 (508)	25.0 (11.3)
81, 83	CS, SS	1½ x 2 (40 x 50)	150	150	4.87 (124)	4.75 (121)	14.48 (368)	29.0 (13.2)
81, 83	CS, SS	1½ x 2 (40 x 50)	300	150	4.87 (124)	4.75 (121)	16.88 (429)	32.0 (14.5)
81, 83	CS, SS	1½ x 2 (40 x 50)	600	150	4.87 (124)	4.75 (121)	20.05 (509)	34.0 (15.4)
81, 83	CS, SS	1½ x 2 (40 x 50)	900	150	5.25 (133)	4.75 (121)	20.43 (519)	39.0 (17.7)
81, 83	CS, SS	1½ x 2 (40 x 50)	1500	150	5.25 (133)	4.75 (121)	21.79 (554)	40.0 (18.1)
81, 83	CS, SS	1½ x 2 (40 x 50)	2500	150	5.87 (149)	4.75 (121)	22.41 (569)	53.0 (24.0)

DIMENSIONS AND WEIGHTS FOR G ORIFICE

Valve model type	Body material	Valve size			Dimensions			Approx. weight lb (kg)
		Inlet by outlet in (DN)	Inlet	Outlet	A in (mm)	B in (mm)	C max ^{[1][2][3]} in (mm)	
81, 83, 81P	Brass, CS, SS	1½ x 2 (40 x 50)	FNPT	FNPT	3.41 (87)	3.50 (89)	20.00 (508)	25.0 (11.3)
81, 83, 81P	CS, SS	1½ x 2 (40 x 50)	150	150	4.87 (124)	4.75 (121)	16.88 (429)	30.0 (13.6)
81, 83, 81P	CS, SS	1½ x 2 (40 x 50)	300	150	4.87 (124)	4.75 (121)	20.05 (509)	32.0 (14.5)
81, 83, 81P	CS, SS	1½ x 2 (40 x 50)	600	150	4.87 (124)	4.75 (121)	20.05 (509)	34.0 (15.4)
81, 83, 81P	CS, SS	1½ x 2 (40 x 50)	900	150	5.25 (133)	4.75 (121)	21.79 (554)	40.0 (18.1)
81, 83, 81P	CS, SS	1½ x 2 (40 x 50)	1500	150	5.25 (133)	4.75 (121)	21.79 (554)	40.0 (18.1)
81P	CS	2 x 3 (50 x 80)	FNPT	FNPT	3.80 (97)	4.96 (126)	22.31 (567)	45.0 (20.4)
81P	CS	2 x 3 (50 x 80)	2500	150	8.12 (206)	4.87 (124)	26.10 (663)	72.0 (32.7)

NOTES

1. Add 2" (51 mm) to 'C max.' dimension for lettered orifice Types 81, 83 with packed lift lever option.
2. Add 1.75" (45 mm) to 'C max.' dimension for lettered orifice 1½" x 2" (40 mm x 50 mm) Type 81P-G with packed lift lever option.
3. Add 2.39" (61 mm) to 'C max.' dimension for lettered orifice 2" x 3" (50 mm x 80 mm) Type 81P-G with packed lift lever option.

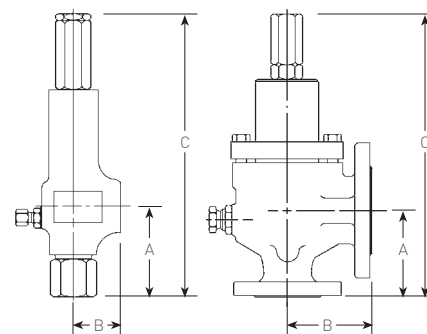

ANDERSON GREENWOOD DIRECT SPRING OPERATED PRESSURE RELIEF VALVES

DIMENSIONS AND WEIGHTS - SERIES 80

DIMENSIONS AND WEIGHTS FOR H ORIFICE

Valve model type	Body material	Valve size			Dimensions			Approx. weight lb (kg)
		Inlet by outlet in (DN)	Connections Inlet Outlet		A in (mm)	B in (mm)	C max ^[1] in (mm)	
81, 83	CS, SS	1½ x 3 (40 x 80)	150	150	5.58 (142)	4.87 (124)	18.73 (476)	51.0 (23.1)
81, 83	CS, SS	1½ x 3 (40 x 80)	300	150	5.83 (148)	4.87 (124)	19.10 (485)	53.0 (24.0)
81, 83	CS, SS	1½ x 3 (40 x 80)	600	150	6.15 (156)	4.87 (124)	24.15 (614)	55.0 (25.0)
81, 83	CS, SS	1½ x 3 (40 x 80)	900	150	6.75 (172)	4.87 (124)	24.75 (629)	69.0 (31.3)
81, 83	CS, SS	1½ x 3 (40 x 80)	1500	150	6.75 (172)	4.87 (124)	24.75 (629)	69.0 (31.3)
81, 83	Brass, CS, SS	2 x 3 (50 x 80)	FNPT	FNPT	3.80 (97)	4.96 (126)	21.80 (554)	45.0 (20.4)
81, 83	CS, SS	2 x 3 (50 x 80)	150	150	5.37 (136)	4.87 (124)	18.45 (469)	51.0 (23.1)
81, 83	CS, SS	2 x 3 (50 x 80)	300	150	5.37 (136)	4.87 (124)	18.45 (469)	53.0 (24.0)
81, 83	CS, SS	2 x 3 (50 x 80)	600	150	5.37 (136)	4.87 (124)	23.37 (594)	55.0 (25.0)
81, 83	CS, SS	2 x 3 (50 x 80)	900	150	6.56 (167)	4.87 (124)	24.56 (624)	69.0 (31.3)
81, 83	CS, SS	2 x 3 (50 x 80)	1500	150	6.56 (167)	4.87 (124)	24.56 (624)	69.0 (31.3)

DIMENSIONS AND WEIGHTS FOR J ORIFICE

Valve model type	Body material	Valve size			Dimensions			Approx. weight lb (kg)
		Inlet by outlet in (DN)	Connections Inlet Outlet		A in (mm)	B in (mm)	C max ^{[1][2][3]} in (mm)	
81, 83, 81P	Brass, CS, SS	2 x 3 (50 x 80)	FNPT	FNPT	3.80 (97)	4.96 (126)	21.80 (554)	45.0 (20.4)
81, 83, 81P	CS, SS	2 x 3 (50 x 80)	150	150	5.37 (136)	4.87 (124)	18.45 (469)	51.0 (23.1)
81, 83, 81P	CS, SS	2 x 3 (50 x 80)	300	150	5.37 (136)	4.87 (124)	23.37 (594)	55.0 (25.0)
81, 83, 81P	CS, SS	2 x 3 (50 x 80)	600	150	5.37 (136)	4.87 (124)	23.37 (594)	55.0 (25.0)
81, 83, 81P	CS, SS	2 x 3 (50 x 80)	900	150	6.56 (167)	4.87 (124)	24.56 (624)	69.0 (31.3)
81, 83, 81P	CS, SS	2 x 3 (50 x 80)	1500	150	6.56 (167)	4.87 (124)	24.56 (624)	69.0 (31.3)

NOTES

1. Add 2.0" (51 mm) to 'C max.' dimension for lettered orifice Types 81, 83 with packed lift lever option.
2. Add 2.39" (61 mm) to 'C max.' dimension for lettered orifice 2" x 3" (50 mm x 80 mm) Type 81P-J with packed lift lever option.
3. 'C max.' dimension for 2" x 3" (50 mm x 80 mm) Type 81P-J orifice with FNPT connections is 22.31" (567 mm).

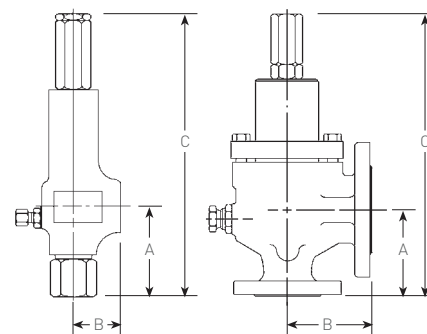

ANDERSON GREENWOOD DIRECT SPRING OPERATED PRESSURE RELIEF VALVES

DIMENSIONS AND WEIGHTS - SERIES 60

TYPE 63B

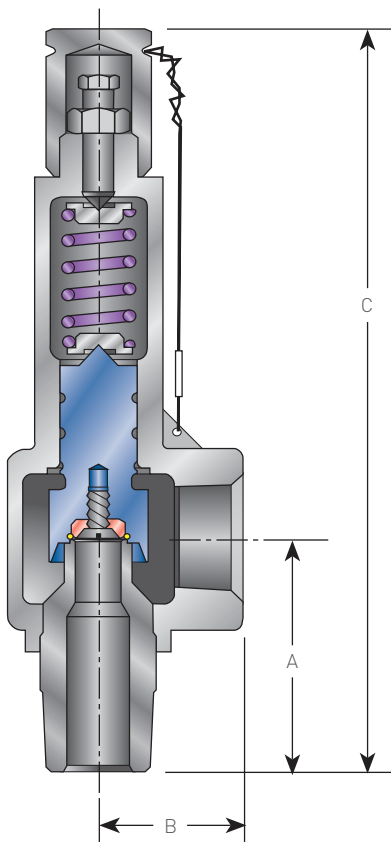

DIMENSIONS AND WEIGHTS FOR -5 ORIFICE, BRASS BODY

Valve model type	Set pressure range	Valve connections				Dimensions			Approx. weight lb (kg)
		in (DN)		Threaded connections		A	B	C max	
		Inlet	Outlet	Inlet	Outlet	in (mm)	in (mm)	in (mm)	
63B	37 - 531 psig (2.6 - 36.6 barg)	½ (15)	1 (25)	FNPT	FNPT	2.25 (57)	1.38 (35)	7.31 (186)	2.5 (1.1)
63B	37 - 531 psig (2.6 - 36.6 barg)	½ (15)	1 (25)	MNPT	FNPT	2.25 (57)	1.38 (35)	7.31 (186)	2.5 (1.1)
63B	37 - 531 psig (2.6 - 36.6 barg)	¾ (20)	1 (25)	MNPT	FNPT	2.25 (57)	1.38 (35)	7.31 (186)	2.5 (1.1)

DIMENSIONS AND WEIGHTS FOR -7 ORIFICE, BRASS BODY

Valve model type	Set pressure range	Valve connections				Dimensions			Approx. weight lb (kg)
		in (DN)		Threaded connections		A	B	C max	
		Inlet	Outlet	Inlet	Outlet	in (mm)	in (mm)	in (mm)	
63B	45 - 374 psig (3.1 - 25.8 barg)	¾ (20)	1 (25)	MNPT	FNPT	2.25 (57)	1.38 (35)	7.31 (186)	2.5 (1.1)

ANDERSON GREENWOOD DIRECT SPRING OPERATED PRESSURE RELIEF VALVES

MATERIALS - SERIES 80

ORIFICE SIZES -4 TO -8

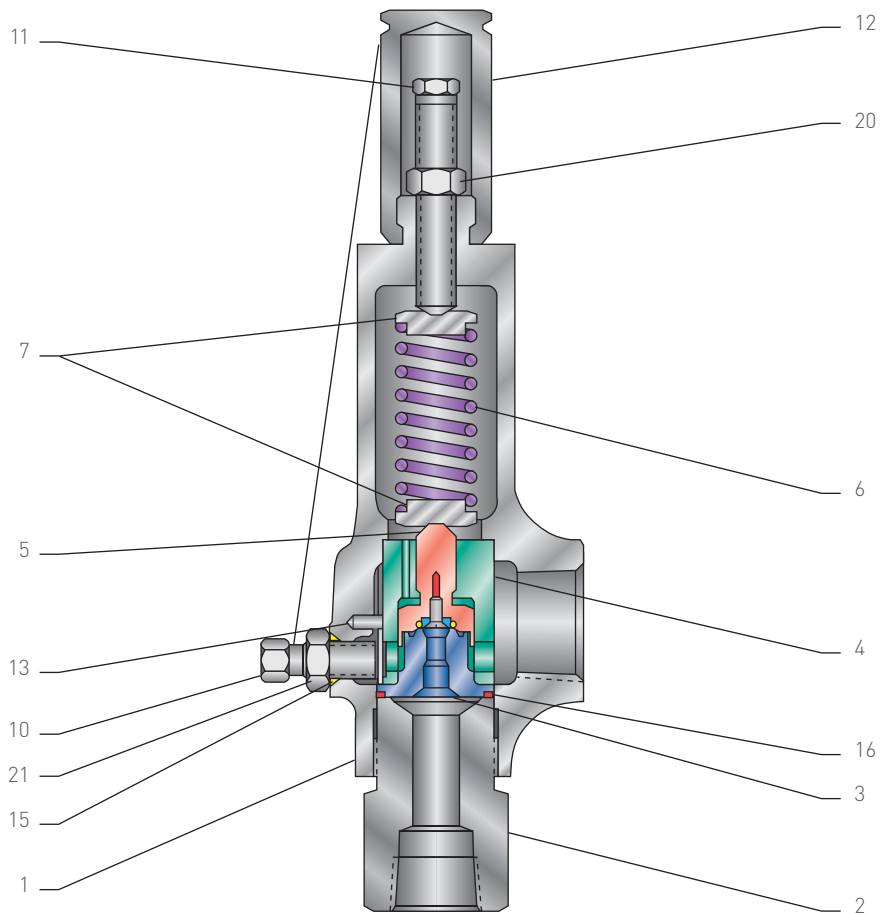

83 SEAT (O-RING)

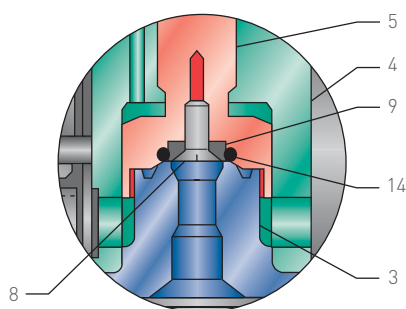

81 (PLASTIC)

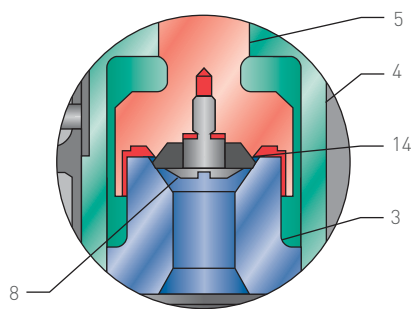

81P SEAT (PLASTIC)

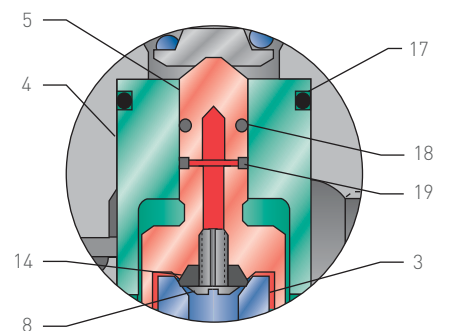

ANDERSON GREENWOOD DIRECT SPRING OPERATED PRESSURE RELIEF VALVES

MATERIALS - SERIES 80

STANDARD MATERIALS^[1] - ORIFICE SIZES -4 TO -8

Item no.	Part name	Bronze/brass	CS ^[2]	SS ^[2]
1	Body	Br. SB62	SA216 WCB CS	SA351-CF8M SS
2	Inlet bushing	Br. B16	-	A479 316 SS
3	Nozzle	Br. B16 ^[3]	A479 316 SS	A479 316 SS
4	Guide	Br. B16 ^[3]	A479 316 SS	A479 316 SS
5	Spindle	Br. B16 ^[3]	A479 316 SS	A479 316 SS
6	Spring	316 SS or 17-7 PH SS	Note 7	316 SS, 17-7 PH SS, or 17-4 PH SS
7	Spring washer	Br. B16	-	A479 316 SS
8	Seat retainer screw	316 SS, 17-4 PH SS ^[4] or Brass ^[5]	17-4 PH SS ^[4] or 316 SS ^[6]	17-4 PH SS ^[4] or 316 SS ^{[5][6]}
9	Seat retainer ^[5]	Br. B16	A276 316 SS	SA 276 316 SS
10	Blowdown adjustment screw or plug ^[6]	Br. B16 or 316 SS	316 SS	316 SS
11	Pressure adjustment screw	Br. B16	A479 316 SS	A479 316 SS
12	Cap	Br. B16 ^[8]	A108 12L14 CS, ^[8]	A479 316 SS ^[9]
13	Drive pin ^[10]	316 SS	316 SS	316 SS
20	Lock nut, pressure adjustment screw	Br. B16	A479 316 SS	A479 316 SS
21	Lock nut, blowdown adjustment screw ^[10]	BRS	A194-8M SS	A194-8M SS

NOTES

- Other materials available on special order.
- Materials may be furnished to meet ANSI/NACE MR0175/ISO 15156-1:2015 for sour gas service. Materials are either heat treated or alternative materials are furnished to factory option to meet NACE.
- 316 SS for Type 81P.
- Type 81.
- Type 83.
- Type 81P.
- 316 SS, 17-7 PH SS, 17-4 PH SS or 1060-1075 CS (aluminum coated) depending upon set pressure.
- Zinc cobalt plated.
- A582-303 for cap with lift lever option.
- Not used on Type 81P.

TYPES 81, 83 STANDARD SEAT MATERIALS -ORIFICE SIZES -4 TO -8

Item no.	Part name	Applicable orifice sizes	Orifice designation, seat option and seal materials	
			Model 81 -4, -6 and -8	Model 83 -4, -6 and -8
14	Seat	All	PTFE ^{[1][2]} - PCTFE ^{[1][2]} - Vespe ^{[1][2]}	NBR ^[1] - EPR - FKM ^[2]
15	Blowdown adjustment screw seal	All	PTFE ^{[1][2]}	PTFE ^{[1][2]}
16	Bushing seal	-4 to -8	Glass filled PTFE ^{[1][2]}	NBR ^[1] - EPR - FKM ^[2]

NOTES

- Factory standard seat and seal materials. Other seat and seal materials available on special order.
- Factory standard seat and seal material: NACE option.

TYPES 81P STANDARD SEAT MATERIALS -ORIFICE SIZES -4 TO -8

Item no.	Part name	Applicable orifice sizes	Orifice designation, seat option and seal materials	
			Model 81P -4 and -8	
14	Seat	All	PTFE ^{[1][2]} - PCTFE ^{[1][2]} - Vespe ^{[1][2]}	
15	Blowdown adjustment screw seal	All	PTFE ^{[1][2]}	
16	Bushing seal	-4 to -8	Glass filled PTFE - NBR ^[1] - EPR - FKM ^[2]	
17	Guide seal	-4 to -8	PTFE ^[3] - NBR ^[1] - EPR - FKM ^[2]	
18	Spindle seal	All	PTFE ^[3] - NBR ^[1] - EPR - FKM ^[2]	
19	Stabilizing ring	All	PTFE ^[3] - NBR ^[1] - EPR - FKM ^[2]	

NOTES

- Factory standard seat and seal materials. Other seat and seal materials available on special order.
- Factory standard seat and seal material: NACE option.
- PTFE seals are available for Types 81P-T -4 and -8 orifice sizes only.

ANDERSON GREENWOOD DIRECT SPRING OPERATED PRESSURE RELIEF VALVES

MATERIALS - SERIES 80

ORIFICE SIZES F TO J

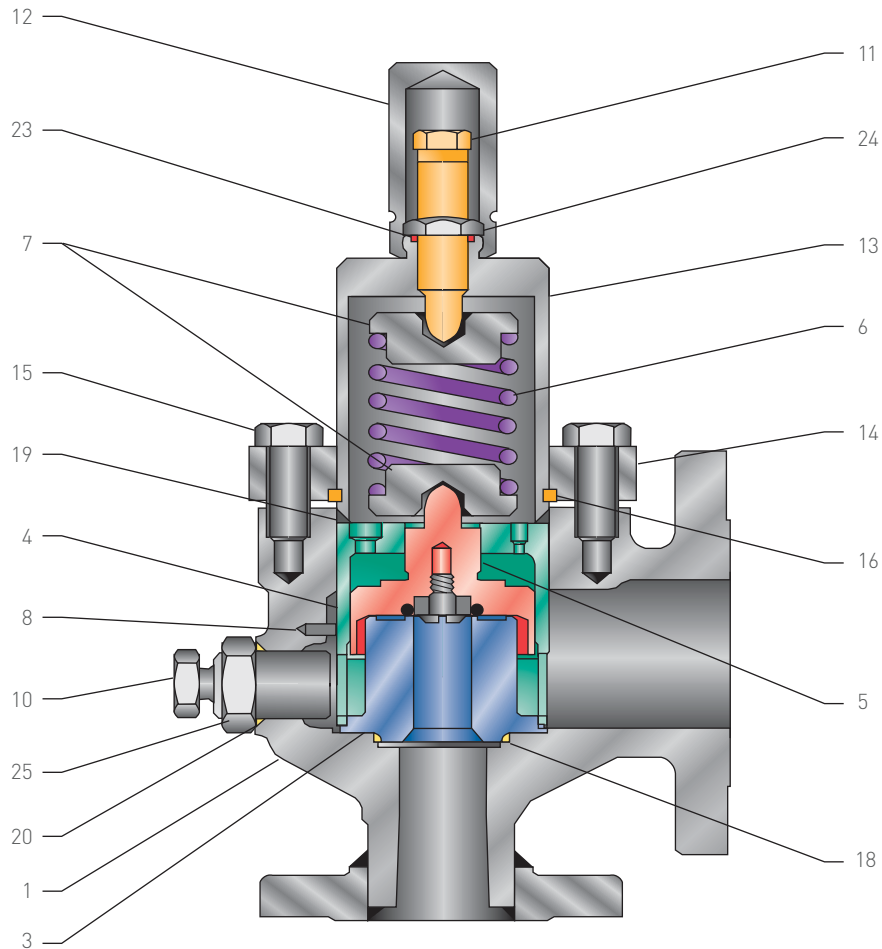

83 SEAT (O-RING)

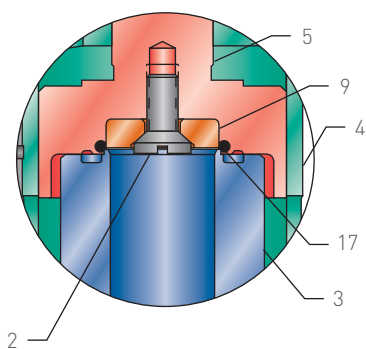

81 (PLASTIC)

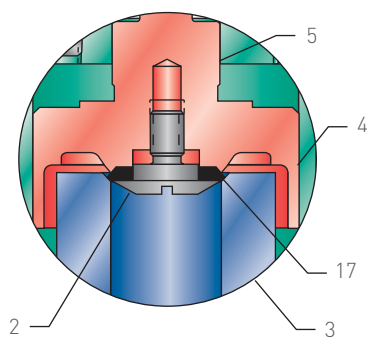

81P SEAT (PLASTIC)

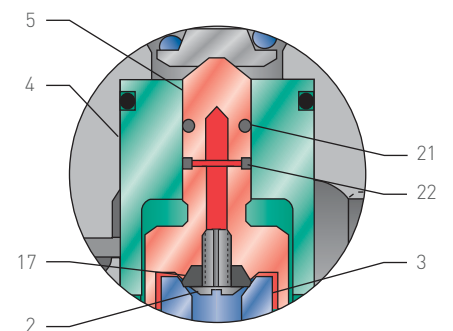

ANDERSON GREENWOOD DIRECT SPRING OPERATED PRESSURE RELIEF VALVES

MATERIALS - SERIES 80

STANDARD MATERIALS⁽¹⁾ - ORIFICE SIZES F TO J

Item no.	Part name	Brass	CS ⁽²⁾	SS ⁽²⁾
1	Body	SB62 BRS	SA216-WCB CS	SA351-CF8M SS
2	Seat retainer screw	17-4 PH SS or 316 SS ⁽⁵⁾	17-4 PH SS or AST ⁽⁵⁾	17-4 PH SS or 316 SS ⁽⁵⁾
3	Nozzle	A479 316 SS ⁽³⁾	A479 316 ⁽³⁾ SS	A479 316 SS ⁽³⁾
4	Guide	A479 316 SS	A479 316 SS	A479 316 SS
5	Spindle	A479 316 SS ⁽³⁾	A479 316 ⁽³⁾ SS	A479 316 SS ⁽³⁾
6	Spring	316 SS or 1060-1075 CS (aluminum coated)	316 SS or 1060-1075 CS (aluminum coated)	316 SS, 17-7 PH SS or 17-4 PH SS
7	Spring washer	A479 316 SS	A479 316 SS	A479 316 SS
8	Drive pin	316 SS	316 SS	316 SS
9	Seat retainer ⁽⁵⁾	A479 316 SS	A479 316 SS	A479 316 SS
10	Blowdown adj. screw or plug	A479 316 SS	A479 316 SS	A479 316 SS
11	Pressure adjustment screw	A479 316 SS	A479 316 SS	A479 316 SS
12	Cap	A479 316 SS	A108 12L14 CS ⁽⁴⁾ , A479 316 SS	A479 316 SS
13	Spring bonnet	A479 316 SS	A105 CS ⁽⁴⁾	A479 316 SS
14	Bonnet flange	A240 316 SS	A516 70 CS ⁽⁴⁾	A240 316 SS
15	Bonnet bolting	A193 B8M SS	A449/A325 ⁽⁴⁾	A193 B8M SS
16	Split ring	A269 304 SS	A106 CS ⁽⁴⁾	A269 304 SS
24	Lock nut, pressure adjustment screw	A479 316 SS	A479 316 SS	A479 316 SS
25	Lock nut, blowdown adjustment screw	A194 B8M SS	A194 B8M SS	A194 B8M SS

NOTES

- Other materials available on special order.
- Materials may be furnished to meet ANSI/NACE MR0175/ISO 15156-1:2015 for sour gas service. Materials are either heat treated or alternative materials are furnished to factory option to meet NACE.
- 17-4 PH SS used for Type 81.
- Zinc cobalt plated.
- Type 83.
- Type 81P.
- Not used on Type 81P.

TYPES 81, 83 STANDARD SEAT MATERIALS -ORIFICE SIZES F TO J

Item no.	Part name	Applicable orifice sizes	Orifice designation, seat option and seal materials	
			Model 81 F, G, H and J	Model 83 F, G, H and J
17	Seat	All	PTFE ⁽¹⁾⁽²⁾ - PCTFE ⁽¹⁾⁽²⁾ - Vespel ⁽¹⁾⁽²⁾	NBR ⁽¹⁾ - EPR - FKM ⁽²⁾
18	Nozzle seal	F to J	PTFE ⁽¹⁾⁽²⁾	NBR ⁽¹⁾ - EPR - FKM ⁽²⁾
19	Bonnet seal	F to J	Glass filled PTFE ⁽¹⁾⁽²⁾	NBR ⁽¹⁾ - EPR - FKM ⁽²⁾
20	Blowdown adjustment screw seal	All	PTFE ⁽¹⁾⁽²⁾	PTFE ⁽¹⁾⁽²⁾
23	Pressure seal	F to J	PTFE ⁽¹⁾⁽²⁾	PTFE ⁽¹⁾⁽²⁾

NOTES

- Factory standard seat and seal materials. Other seat and seal materials available on special order.
- Factory standard seat and seal material: NACE option.

TYPES 81P STANDARD SEAT MATERIALS -ORIFICE SIZES F TO J

Item no.	Part name	Applicable orifice sizes	Orifice designation, seat option and seal materials	
			Model 81P -4 and -8	
14	Seat	All	PTFE ⁽¹⁾⁽²⁾ - PCTFE ⁽¹⁾⁽²⁾ - Vespel ⁽¹⁾⁽²⁾	
15	Blowdown adjustment screw seal	All	PTFE ⁽¹⁾⁽²⁾	
16	Bushing seal	-4 to -8	NBR ⁽¹⁾ - EPR - FKM ⁽²⁾	
17	Guide seal	-4 to -8	NBR ⁽¹⁾ - EPR - FKM ⁽²⁾	
18	Spindle seal	All	NBR ⁽¹⁾ - EPR - FKM ⁽²⁾	
19	Stabilizing ring	All	NBR ⁽¹⁾ - EPR - FKM ⁽²⁾	

NOTES

- Factory standard seat and seal materials. Other seat and seal materials available on special order.
- Factory standard seat and seal material: NACE option.

ANDERSON GREENWOOD DIRECT SPRING OPERATED PRESSURE RELIEF VALVES

MATERIALS - SERIES 60

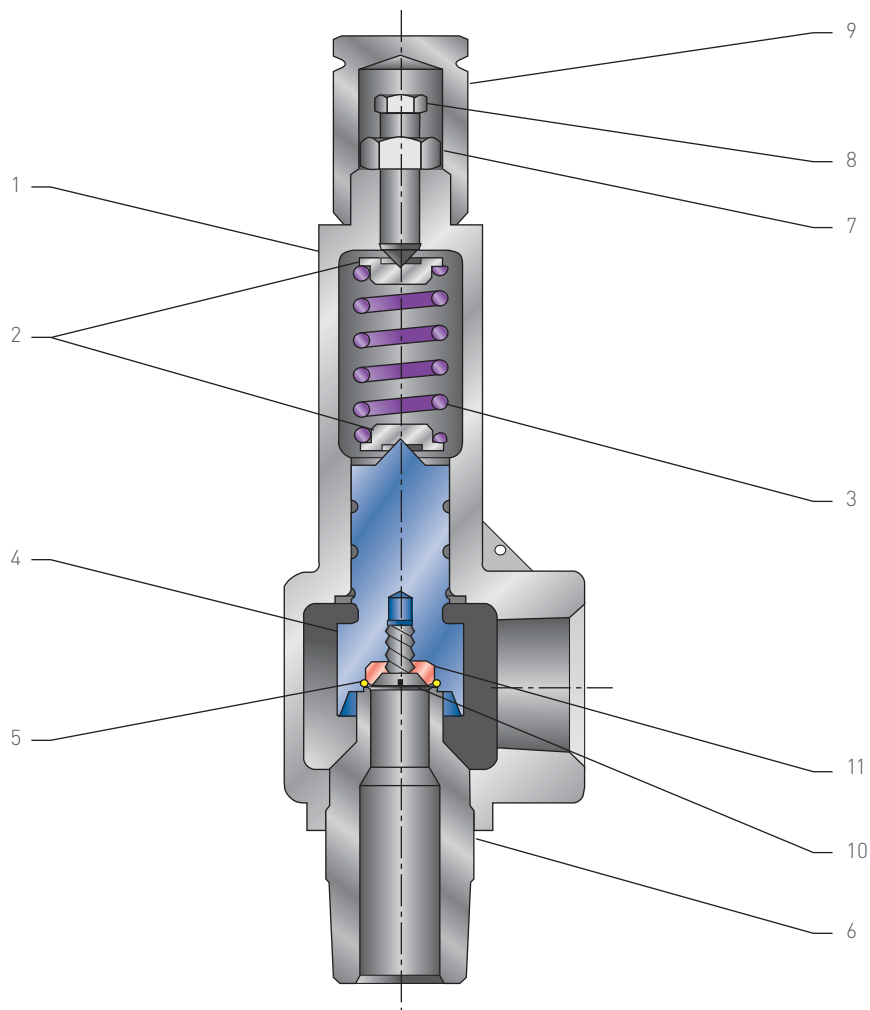

Type 63B

STANDARD MATERIALS

Item no.	Part name	Material
1	Body	BRS SB62
2	Spring washer	A582 303 SS
3	Spring	316 SS or 17-7 PH SS
4	Spindle	A582 303 SS (Type 63B)
5	Seat	NBR, FKM, EPR (Type 63B)
6	Nozzle	BRS B16
7	Lock nut	A307 steel (Type 63B)
8	Pressure adjustment screw	A108 12L14 CS (Type 63B)
9	Cap	BRS B16
10	Seat retainer screw	316 SS (Type 63B)
11	Seat retainer	A582 303 SS (Type 63B)

NOTE

- Standard seat material.

ANDERSON GREENWOOD DIRECT SPRING OPERATED PRESSURE RELIEF VALVES

CAPACITIES - SERIES 80

TYPES 81 AND 83 CAPACITIES^[1]

SCFM (Nm³/hr) AIR, NATIONAL BOARD CERTIFIED

Set pressure psig (barg)	-4 0.049 in ² (0.32 cm ²)	-6 0.110 in ² (0.71 cm ²)	-8 0.196 in ² (1.26 cm ²)	F 0.307 in ² (1.98 cm ²)	G 0.503 in ² (3.25 cm ²)	H 0.785 in ² (5.07 cm ²)	J 1.287 in ² (8.30 cm ²)
20 (1.38)	28 (45.0)	62 (99.7)	111 (178.5)	173 (278.2)	284 (456.7)	443 (712.3)	726 (1167.4)
40 (2.76)	43 (69.1)	97 (156.0)	172 (276.6)	270 (434.2)	442 (710.7)	689 (1107.9)	1130 (1817.0)
60 (4.14)	59 (94.9)	133 (213.9)	237 (381.1)	371 (596.6)	607 (976.1)	948 (1524.4)	1554 (2492.6)
80 (5.52)	75 (120.6)	169 (271.8)	301 (484.0)	472 (759.0)	773 (1243.0)	206 (1939.2)	1997 (3211.2)
100 (6.9)	91 (146.3)	205 (329.6)	366 (588.5)	573 (921.4)	938 (1508.3)	1464 (2354.1)	2401 (3860.8)
120 (8.3)	108 (173.7)	241 (387.5)	430 (691.4)	674 (1083.8)	1104 (1775.2)	1723 (2770.6)	2824 (4541.0)
140 (9.7)	124 (199.4)	278 (447.0)	495 (796.0)	775 (1246.2)	1269 (2040.6)	1981 (3185.5)	3248 (5222.8)
160 (11.0)	140 (225.1)	314 (504.9)	559 (898.9)	876 (1408.6)	1435 (2307.5)	2239 (3600.3)	3671 (5903.0)
180 (12.4)	156 (250.9)	350 (562.8)	624 (1003.4)	977 (1571.0)	1600 (2572.8)	2498 (4016.8)	4095 (6584.8)
200 (13.8)	172 (276.6)	386 (620.7)	688 (1106.3)	1078 (1733.4)	1766 (2839.7)	2756 (4431.7)	4518 (7264.9)
240 (16.6)	204 (328.0)	459 (738.1)	817 (1313.7)	1280 (2058.2)	2097 (3372.0)	3273 (5263.0)	5365 (8626.9)
280 (19.3)	237 (381.1)	531 (853.9)	946 (1521.2)	1482 (2383.1)	2428 (3904.2)	3789 (6092.7)	6212 (9988.9)
300 (20.7)	253 (406.8)	567 (911.7)	1011 (1625.7)	1583 (2545.5)	2594 (4171.2)	4048 (6509.2)	6636 (10,670.7)
340 (23.4)	285 (458.3)	640 (1029.1)	1140 (1833.1)	1785 (2870.3)	2925 (4703.4)	4564 (7338.9)	7483 (12,032.7)
380 (26.2)	317 (509.7)	712 (1144.9)	1269 (2040.6)	1987 (3195.1)	3256 (5235.7)	5081 (8170.2)	8330 (13,394.6)
400 (27.6)	333 (535.5)	748 (1202.8)	1333 (2143.5)	2088 (3357.5)	3421 (5501.0)	5339 (8585.1)	8754 (14,076.4)
440 (30.3)	366 (588.5)	821 (1320.2)	1462 (2350.9)	2290 (3682.3)	3752 (6033.2)	5856 (9416.5)	9601 (15,438.4)
480 (33.1)	398 (640.0)	893 (1435.9)	1591 (2558.3)	2492 (4007.1)	4083 (6565.5)	6373 (10,247.8)	10,448 (16,800.4)
500 (34.5)	414 (665.7)	929 (1493.8)	1656 (2662.9)	2593 (4169.5)	4249 (6832.4)	6631 (10,662.6)	10,871 (17,480.6)
600 (41.4)	495 (796.0)	1110 (1784.9)	1978 (3180.6)	3098 (4981.6)	5076 (8162.2)	7922 (12,738.6)	12,989 (20,886.3)
700 (48.3)	575 (924.6)	1291 (2075.9)	2301 (3700.0)	3603 (5793.6)	5904 (9493.6)	9214 (14,816.1)	15,106 (24,290.5)
800 (55.2)	656 (1054.9)	1472 (2367.0)	2623 (4217.8)	4109 (6607.3)	6732 (10,825.1)	10,506 (16,893.7)	17,224 (27,696.2)
900 (62.1)	736 (1183.5)	1653 (2658.0)	2946 (4737.2)	4614 (7419.3)	7559 (12,154.9)	11,797 (18,969.6)	19,342 (31,101.9)
1000 (69.0)	817 (1313.7)	1834 (2949.0)	3268 (5254.9)	5119 (8231.4)	8387 (13,486.3)	13,089 (21,047.1)	21,459 (34,506.0)
1500 (103.4)	1220 (1961.8)	2739 (4404.3)	4881 (7848.7)	7645 (12,293.16)	12,525 (20,140.2)	19,547 (31,431.6)	32,048 (51,533.2)
2000 (137.9)	1623 (2609.8)	3644 (5859.6)	6493 (10,440.7)	10,170 (16,353.4)	16,663 (26,774.1)	26,006 (41,817.7)	----
2500 (172.4)	2026 (3257.8)	4549 (7314.8)	8106 (13,034.5)	12,696 (20,415.2)	20,802 (33,449.6)	32,464 (52,202.1)	----
3000 (206.9)	2430 (3907.4)	5454 (8770.0)	9718 (15,626.5)	15,222 (24,476.98)	----	----	----
4000 (275.8)	3236 (5203.5)	7264 (11,680.5)	12,943 (20,812.3)	20,273 (32,599.0)	----	----	----
5000 (344.8)	4042 (6499.5)	9074 (14,591.0)	16,168 (25,998.1)	----	----	----	----
6000 (413.7)	4848 (7795.6)	10,884 (17,501.5)	19,393 (31,183.9)	----	----	----	----
7000 (482.7)	5655 (9093.2)	12,694 (20,412.0)	----	----	----	----	----
8000 (551.6)	6461 (10,389.3)	14,504 (23,322.4)	----	----	----	----	----
9000 (620.6)	7267 (11,685.3)	16,314 (26,232.9)	----	----	----	----	----
10,000 (689.5)	8073 (12,981.4)	----	----	----	----	----	----

NOTES

- 60°F (16°C), Z = 1.00; 10% overpressure or 3 psig (0.21 barg) (whichever is greater).
- Metric conversions:
 barg = psig x 0.06895
 cm² = in² x 6.4516
 Nm³/hr = SCFM x 1.608
 °C = (°F - 32) x 0.5556

ANDERSON GREENWOOD DIRECT SPRING OPERATED PRESSURE RELIEF VALVES

CAPACITIES - SERIES 80

TYPES 81 AND 83 CAPACITIES

SCFM (Nm³/hr) NATURAL GAS - MOLECULAR WEIGHT = 17.4

Set pressure psig (barg)	-4 0.049 in ² (0.32 cm ²)	-6 0.110 in ² (0.71 cm ²)	-8 0.196 in ² (1.26 cm ²)	F 0.307 in ² (1.98 cm ²)	G 0.503 in ² (3.25 cm ²)	H 0.785 in ² (5.07 cm ²)	J 1.287 in ² (8.30 cm ²)
20 (1.38)	34 (54.7)	75 (120.6)	134 (215.5)	210 (337.7)	344 (553.2)	537 (863.5)	881 (1416.7)
40 (2.76)	54 (86.8)	120 (193.0)	215 (345.7)	336 (540.3)	551 (886.0)	859 (1381.3)	1409 (2265.7)
60 (4.14)	74 (119.0)	166 (266.9)	295 (474.4)	462 (742.9)	757 (1217.3)	1181 (1899.0)	1937 (3114.7)
80 (5.52)	94 (151.2)	211 (339.3)	375 (603.0)	588 (945.5)	963 (1548.5)	1504 (2418.4)	2465 (3963.7)
100 (6.9)	114 (183.3)	256 (411.6)	456 (733.2)	714 (1148.1)	1170 (1881.4)	1826 (2936.2)	2993 (4812.7)
120 (8.3)	134 (215.5)	301 (484.0)	536 (861.9)	840 (1350.7)	1376 (2212.6)	2148 (3454.0)	3521 (5661.8)
140 (9.7)	154 (247.6)	346 (556.4)	617 (992.2)	966 (1553.3)	1583 (2545.5)	2470 (3971.8)	4049 (6510.8)
160 (11.0)	174 (279.8)	391 (628.7)	697 (1120.8)	1092 (1755.9)	1789 (2876.7)	2792 (4489.5)	4577 (7359.8)
180 (12.4)	194 (312.0)	436 (701.1)	778 (1251.0)	1218 (1958.5)	1995 (3208.0)	3114 (5007.3)	5105 (8208.8)
200 (13.8)	214 (344.1)	481 (773.5)	858 (1379.7)	1344 (2161.2)	2202 (3540.8)	3436 (5525.1)	5634 (9059.5)
240 (16.6)	255 (410.0)	572 (919.8)	1019 (1638.6)	1596 (2566.4)	2615 (4197.1)	4080 (6560.6)	6690 (10,757.5)
280 (19.3)	295 (474.4)	662 (1064.5)	1180 (1897.4)	1848 (2971.6)	3027 (4867.4)	4725 (7597.8)	7746 (12,455.6)
300 (20.7)	315 (506.5)	707 (1136.9)	1260 (2026.1)	1974 (3174.2)	3234 (5200.3)	5047 (8115.6)	8274 (13,304.6)
340 (23.4)	355 (570.8)	797 (1281.6)	1421 (2285.0)	2226 (3579.4)	3646 (5862.8)	5691 (9151.1)	9330 (15,002.6)
380 (26.2)	395 (635.2)	888 (1427.9)	1582 (2543.9)	2478 (3984.6)	4059 (6526.9)	6335 (10,186.7)	10,386 (16,700.7)
400 (27.6)	416 (668.9)	933 (1500.3)	1662 (2672.5)	2603 (4185.6)	4266 (6859.7)	6657 (10,704.5)	10,914 (17,549.7)
440 (30.3)	456 (733.2)	1023 (1645.0)	1823 (2931.4)	2855 (4590.8)	4678 (7522.2)	7301 (11,740.0)	11,970 (19,247.8)
480 (33.1)	496 (797.6)	1113 (1789.7)	1984 (3190.3)	3107 (4996.1)	5091 (8186.3)	7945 (12,775.6)	13,027 (20,947.4)
500 (34.5)	516 (829.7)	1159 (1836.7)	2064 (3318.9)	3233 (5198.7)	5298 (8519.2)	8268 (13,294.9)	13,555 (21,796.4)
600 (41.4)	617 (992.1)	1384 (2225.5)	2466 (3965.3)	3863 (6211.7)	6329 (10,177.0)	9878 (15,883.8)	16,195 (26,041.6)
700 (48.3)	717 (1152.9)	1610 (2588.9)	2868 (4611.7)	4493 (7224.7)	7361 (11,836.5)	11,488 (18,408.4)	18,835 (30,287.0)
800 (55.2)	818 (1315.3)	1836 (2952.3)	3271 (5259.8)	5123 (8237.8)	8393 (13,495.9)	13,099 (21,063.2)	21,476 (34,533.4)
900 (62.1)	918 (1476.1)	2061 (3314.1)	3673 (5906.2)	5753 (9250.8)	9425 (15,155.4)	14,709 (23,652.1)	24,116 (38,779.0)
1000 (69.0)	1019 (1638.6)	2287 (3677.5)	4075 (6552.6)	6382 (10,262.3)	10,457 (16,814.9)	16,320 (26,242.6)	26,756 (43,023.6)
1500 (103.4)	1521 (2445.8)	3415 (5491.3)	6085 (9784.7)	9532 (15,327.5)	15,617 (25,112.1)	24,372 (39,190.2)	39,958 (64,252.5)
2000 (137.9)	2024 (3254.6)	4544 (7306.8)	8096 (13,018.4)	12,681 (20,391.0)	20,776 (33,407.8)	32,425 (52,139.4)	----
2500 (172.4)	2527 (4063.4)	5672 (9120.6)	10,106 (16,250.5)	15,830 (25,454.6)	25,936 (41,705.1)	40,477 (65,087.1)	----
3000 (206.9)	3029 (4870.6)	6800 (10,934.4)	12,117 (19,484.1)	18,979 (30,518.2)	----	----	----
4000 (275.8)	4034 (6486.7)	9057 (14,563.7)	16,138 (25,949.9)	25,277 (40,565.0)	----	----	----
5000 (344.8)	5040 (8104.3)	11,314 (18,192.9)	0,159 (32,415.7)	----	----	----	----
6000 (413.7)	6045 (9720.4)	13,570 (21,820.6)	24,180 (38,881.4)	----	----	----	----
7000 (482.7)	7050 (11,336.4)	15,827 (25,449.8)	----	----	----	----	----
8000 (551.6)	8056 (12,954.0)	18,084 (29,079.1)	----	----	----	----	----
9000 (620.6)	9061 (14,570.0)	20,431 (32,853.1)	----	----	----	----	----
10,000 (689.5)	10,066 (10,750.5)	----	----	----	----	----	----

NOTES

- 60°F (16°C), Z = 1.00; 10% overpressure or 3 psig (0.21 barg) (whichever is greater).
- Metric conversions:
 barg = psig x 0.06895
 cm² = in² x 6.4516
 Nm³/hr = SCFM x 1.608
 °C = (°F - 32) x 0.5556

ANDERSON GREENWOOD DIRECT SPRING OPERATED PRESSURE RELIEF VALVES

CAPACITIES - SERIES 80

TYPE 81P CAPACITIES^[1]

GPM (m³/hr) WATER - NATIONAL BOARD CERTIFIED

Set pressure psig (barg)	-4	-8	G	J
	0.049 in ² (0.32 cm ²)	0.196 in ² (1.27 cm ²)	0.503 in ² (3.25 cm ²)	1.287 in ² (8.30 cm ²)
50 (3.45)	10 (2.3)	40 (9.1)	102 (23.2)	261 (59.3)
100 (6.9)	14 (3.2)	56 (12.7)	144 (32.7)	369 (83.8)
150 (10.3)	17 (3.9)	69 (15.7)	177 (40.2)	452 (102.6)
200 (13.8)	20 (4.5)	80 (18.2)	204 (46.3)	522 (118.5)
250 (17.2)	22 (5.0)	89 (20.2)	228 (51.8)	584 (132.6)
300 (20.7)	24 (5.5)	97 (22.0)	250 (56.8)	640 (145.3)
350 (24.1)	26 (5.9)	105 (23.9)	270 (61.3)	691 (156.9)
400 (27.6)	28 (6.4)	112 (25.4)	289 (65.6)	739 (167.8)
450 (31.0)	30 (6.8)	119 (27.0)	306 (69.5)	783 (177.8)
500 (34.5)	31 (7.0)	126 (28.6)	323 (73.4)	826 (187.6)
600 (41.4)	34 (7.7)	138 (31.3)	354 (80.4)	905 (205.5)
700 (48.3)	37 (8.4)	149 (33.8)	382 (86.8)	977 (221.9)
800 (55.1)	40 (9.1)	159 (36.1)	408 (92.7)	1045 (237.3)
900 (62.1)	42 (9.5)	169 (38.4)	433 (98.3)	1108 (251.6)
1000 (68.9)	44 (10.0)	178 (40.4)	456 (103.6)	1168 (265.3)
1250 (86.2)	50 (11.4)	199 (45.2)	510 (115.8)	1306 (296.6)
1500 (103.4)	54 (12.3)	218 (49.5)	559 (127.0)	1430 (324.8)
1750 (120.6)	59 (13.4)	235 (53.4)	604 (137.2)	----
2000 (137.9)	63 (14.3)	252 (57.2)	645 (146.5)	----
2250 (155.1)	67 (15.2)	267 (60.6)	685 (155.6)	----
2500 ^[2] (172.4)	70 (15.9)	281 (63.8)	722 (164.0)	----
2750 ^[2] (189.6)	74 (16.8)	295 (67.0)	757 (171.9)	----
3000 ^[2] (206.9)	77 (17.5)	308 (70.0)	791 (179.6)	----
4000 ^[2] (275.8)	89 (20.2)	356 (80.8)	913 (207.3)	----
5000 ^[2] (344.8)	99 (22.5)	398 (90.4)	1021 (231.9)	----
6000 ^[2] (413.7)	109 (24.8)	436 (99.0)	1118 (253.9)	----

NOTES

- Saturation temperature - 10% overpressure.
- Metric conversions:
 barg = psig x 0.06895
 cm² = in² x 6.4516
 kg/hr = lb/hr x 0.4536
 °C = (°F - 32) x 0.5556

ANDERSON GREENWOOD DIRECT SPRING OPERATED PRESSURE RELIEF VALVES

CAPACITIES - SERIES 60

TYPE 63B CAPACITIES^[1]

SCFM (Nm³/hr)

Set pressure psig (barg)	Air, National Board certified		Natural gas ^[2]	
	-5 0.077 in ² (0.497 cm ²)	-7 0.150 in ² (0.968 cm ²)	-5 0.077 in ² (0.497 cm ²)	-7 0.150 in ² (0.968 cm ²)
40 (2.76)	69 (111.0)	----	86 (138.3)	----
60 (4.14)	95 (152.8)	191 (307.1)	119 (191.4)	238 (382.7)
80 (5.52)	121 (194.6)	243 (390.7)	151 (242.8)	303 (487.2)
100 (6.90)	147 (236.4)	296 (476.0)	183 (294.3)	368 (591.7)
120 (8.27)	173 (278.2)	348 (559.6)	216 (347.3)	433 (696.3)
140 (9.65)	199 (320.0)	400 (643.2)	248 (398.8)	498 (800.8)
160 (11.03)	225 (361.8)	452 (726.8)	280 (450.2)	563 (905.3)
180 (12.41)	251 (403.6)	504 (810.4)	313 (503.3)	628 (1009.8)
200 (13.79)	277 (445.4)	556 (894.0)	345 (554.8)	693 (1114.3)
220 (15.17)	303 (487.2)	608 (977.7)	377 (606.2)	758 (1218.9)
240 (16.55)	329 (529.0)	661 (1062.9)	410 (659.3)	823 (1323.4)
260 (17.92)	355 (570.8)	713 (1146.5)	442 (710.7)	888 (1427.9)
280 (19.31)	381 (612.6)	765 (1230.1)	474 (762.2)	953 (1532.4)
300 (20.69)	407 (654.5)	817 (1313.7)	507 (815.3)	1018 (1636.9)
320 (22.06)	433 (696.3)	869 (1397.4)	539 (866.7)	1082 (1739.9)
340 (23.44)	459 (738.1)	921 (1481.0)	571 (918.2)	1147 (1844.4)
360 (24.82)	485 (779.9)	973 (1564.6)	604 (971.2)	1212 (1948.9)
380 (26.20)	511 (821.7)	----	636 (1022.7)	----
400 (27.58)	537 (863.5)	----	668 (1074.1)	----
420 (28.96)	563 (905.3)	----	701 (1127.2)	----
440 (30.34)	588 (945.5)	----	733 (1178.7)	----
460 (31.72)	614 (987.3)	----	765 (1230.1)	----
480 (33.10)	640 (1029.1)	----	798 (1283.2)	----
500 (34.48)	666 (1070.9)	----	830 (1334.6)	----
520 (35.85)	692 (1112.7)	----	862 (1386.1)	----

NOTES

- 60°F (16°C), Z = 1.00; 10% overpressure.
- Molecular weight = 17.4.
- Metric conversions:
 barg = psig x 0.06895
 cm² = in² x 6.4516
 °C = (°F - 32) x 0.5556
 Nm³/hr = SCFM x 1.608

ANDERSON GREENWOOD DIRECT SPRING OPERATED PRESSURE RELIEF VALVES

ORDERING - SERIES 60 AND 80

ACCESSORIES AND OPTIONS

Packed lift lever

Available for all Series 80 valves, the packed lift lever allows the valve to be actuated manually at system operating pressures at least 75% of set pressure, with no process venting through the lever mechanism.

Paragraph 3.2.7(a) of the ASME Boiler and Pressure Vessel Code Section VIII and XIII (UV Designator), requires a lifting device for pressure relief valves on air and hot water services above 140°F (60°C).

Test gags

A test gag can be provided to prevent valve opening during system hydrotests.

NACE option (essential for sour gas service)

Optional materials of construction are available for special applications or conditions involving corrosive fluids. All materials used in the primary (wetted while the valve is closed) pressure zone of the pressure relief valve meet the material requirements of the current revision of ANSI/NACE MR0175/ISO 15156-1:2015. Contact your sales representative for specific compliance to NACE requirements. Special cleanings, coatings and lubricants are also available on application.

The purchaser must decide whether their specific application requires compliance to NACE recommendations. Emerson will provide materials that meet the material requirements in the requested NACE specification; however, the purchaser must ensure all valve materials selected meet their application's NACE requirements.



AVAILABILITY OF ACCESSORIES AND OPTIONS

Accessory/option	Valve Type			
	81	83	81P	63B
Packed Lift Lever	Optional	Optional	Optional	Not Available
NACE Trim	Optional	Optional	Optional	Not Available
Test Gag	Optional	Optional	Optional	Not Available

ANDERSON GREENWOOD DIRECT SPRING OPERATED PRESSURE RELIEF VALVES

ORDERING - SERIES 60 AND 80

ORDERING - ADDITIONAL INFORMATION

After selecting the valve type, orifice and materials of construction, the following information might be required, depending on the type of valve and other requirements:

Flanged valves

If ordering a flanged valve, separately specify pressure class, facing and finish for both the inlet and outlet. To ensure prompt delivery, please follow the specified flange practices as listed in the ANSI standards. When the model number describes flanged connections, the flange dimensions and finish will meet these standards. Any deviation from the standard must be specified clearly.

Service

Provide the specific name of the fluid and state to be relieved. When small amounts (including trace amounts) of other fluids are present, indicate their name and concentration. This is important both for the selection of metallic components and the soft seats and seals. Note that certain valve models are recommended for gas or liquid service.

Documentation

Unless specified, data submittals are not supplied for products ordered. Certain standard drawings, test reports and certifications are available at no cost on request.

Packing for shipment

All products are packed for normal domestic shipment from point of assembly or stocking. Special packaging requirements, such as export boxing, should be specified in your purchase order.

Soft goods code

The code shown (right) is stamped on the valve's nameplate for easy identification in the field.

Temperature

Furnish the normal operating temperature and the relieving temperature. When the ambient temperature varies significantly from normal conditions, such as arctic environments, also supply that temperature. It is more important to select the seat and seal materials on the basis of the continuous service temperature. The pressure-containing parts of the pressure relief valve should consider the three temperature conditions of continuous service, relieving and ambient.

Set pressure

Specify set pressure in psig or other commonly accepted units. If set pressure is given in absolute terms, 14.7 psig (1.01 barg) will be deducted to establish the factory setting. This gauge pressure value will be applied to the valve name plate.

Seat material

B - NBR
V - FKM
E - Ethylene propylene
R - NBR, CO₂ service (seat material only)
Type 83: -4, -6, -8
Orifice set pressures 720 psig [49.6 barg] and up
A - Aflas
Z - FFKM
T - PTFE
K - PCTFE
W - Vespel
P - PEEK

Seal material

B - NBR
V - FKM
E - Ethylene propylene
A - Aflas
Z - FFKM
T - PTFE

Special requirements

Please specify the details of any special procedures you require during valve manufacturing. These might include unlisted accessories, special quality assurance, material traceability, non-standard plating and surface finishes, non-destructive test requirements, etc.

Include required levels of inspection and the parties or organizations which will perform the inspections, if any. Special requirements can impact price and delivery.

Valve tagging

If paper tags are requested at the time of ordering, they will be supplied at a small additional cost. Other types of tagging are also offered at additional cost. If you would like metallic tags, please identify the specific tag material and tag numbers when you place your order.

ANDERSON GREENWOOD DIRECT SPRING OPERATED PRESSURE RELIEF VALVES

ORDERING - SERIES 60 AND 80

SELECTION GUIDE

Example:	81P	S1	N	S	8	A	16	A	-8	L
Valve type										
81 Plastic seated, gas service										
83 O-ring seated, gas service										
81P Plastic seated, liquid service										
63 O-ring seated, gas service										
Body material										
S 316 SS										
S1 CS with 316 SS trim										
B Brass (NPT only)										
NACE										
N Materials to meet ANSI/NACE MR0175/ISO 15156-1:2015										
Blank Standard (without NACE)										
Port type										
F Threaded FNPT inlet and outlet										
M Threaded MNPT inlet and threaded FNPT outlet										
J Threaded MS-33649 inlet and outlet (military standard)										
S Slip-on flanged inlet and outlet ⁽¹⁾⁽²⁾										
W Weldneck flanged inlet and outlet										
U Weldneck flanged inlet and integral cast flanged outlet										
L Lap joint flanged inlet and integral cast flanged outlet										
T Weldneck flanged inlet and FNPT outlet										
X Slip-on flanged inlet and FNPT outlet										
Y Slip-on flanged inlet and weldneck flanged outlet										
Blank Special										
Inlet size, 1/8"										
4 1/2" (DN 15)			12	1 1/2" (DN 40)						
6 3/4" (DN 20)			16	2" (DN 50)						
8 1" (DN 25)										
Inlet flange rating										
A 150#			D	900#						
B 300#			E	1500#						
C 600#			F	2500#						
Blank Not applicable (threaded inlet)										
Outlet size, 1/8"										
6 3/4" (DN 20)			16	2" (DN 50)						
8 1" (DN 25)			24	3" (DN 80)						
12 1 1/2" (DN 40)										
Outlet flange rating										
A 150#			D	900#	Blank	Not applicable (threaded outlet)				
B 300#			E	1500#						
C 600#			F	2500#						
Orifice										
-4 0.049 in ² (0.32 cm ²)					-E	0.196 in ² (1.27 cm ²) (Types 81 and 81P set over 4000 psig (276 barg))				
-5 0.077 in ² (0.50 cm ²) (Type 63B only)					-F	0.307 in ² (1.98 cm ²)				
-6 0.110 in ² (0.71 cm ²) (D)					-G	0.503 in ² (3.25 cm ²)				
-7 0.150 in ² (0.968 cm ²) (Type 63B only)					-H	0.785 in ² (5.07 cm ²)				
-8 0.196 in ² (1.27 cm ²) (Types 81 and 81P to 4000 psig (276 barg) and Type 83 to 2000 psig (137.8 barg))					-J	1.287 in ² (8.30 cm ²)				
Lift lever										
L Packed lift lever										
Blank Standard, without lift lever										
Cryogenic 81P										
-T With PTFE Seals (-4 and -8 Orifice Size only)										
Blank Not Applicable (Standard seal design)										

Example 1: 81PS1NS8A16A-8L: 81P liquid relief valve, A21 6 WCB CS body, 316 SS trim, valve built to ANSI/NACE MR0175/ISO 15156-1:2015, 1" (DN 25) - 150# RF x 2" (DN 50) - 150# RF connections, 0.196 in² (1.27 cm²) orifice, packed lifting lever.

Example 2: 81PSS8A8A-8-T: 81P liquid relief valve, 316 SS body, 316 SS trim, 1" (DN 25) - 150# RF x 2" (DN 50) - 150# RF connections, 0.196 in² (1.27 cm²) orifice, Cryogenic PTFE Seals

NOTES

- Outlet flanges may be upgraded to integrally cast on numbered orifices.
- Inlet flanges on lettered orifice valves are integrally cast.