



## ANDERSON GREENWOOD LIQUID STORAGE INTERNAL TANK VALVES

Fail-safe isolation valves for bottom and side withdrawal tanks available in pivot-type, plug-type and side-mounted pivot-type models



### FEATURES

- Fail safe isolation as the weight of the disc will always close the ITV when not being held open by the operator.
- Self-seating disc designs provide perfect seating regardless of minor misalignments.
- All SS construction and PTFE-coated rotating joints surface provide full compatibility with cryogenic temperatures.
- Eliminates damaging up-loads on the tank bottom by limiting the force from the open and close operators.
- Redundant opening cables provided to allow manual operation if necessary.
- Pressure equalizing pilot valve integral with the valve disc.
- Anti-vortex vanes counter the Coriolis effect, preventing lowered pressure and resulting product gasification during withdrawal.
- Explosion-proof position indication limit switch (NEMA Type 7, Class 1, Groups C and D) mounted on the open operator available as an option.
- Auxiliary close cables augment normal sealing forces and improve the system's manageability.
- Control panel option includes all components in a single weather-tight enclosure designed for roof installation and remote operation.

### GENERAL APPLICATION

Suitable for LNG peak shaving facilities, base load liquefaction facilities, import/receiving terminals that require high inflow velocities and side withdrawal double-walled tanks for liquid storage including LNG, LPG, NH<sub>3</sub>, LOX and LIN.

### TECHNICAL DATA

Sizes  
Pivot-type: NPS 4 to 18 (DN 100 to 450)  
Plug-type: NPS 6 to 30 (DN 150 to 750)  
Side-mounted  
pivot-type: NPS 12 to 18 (DN 300 to 450)

Maximum fill rates  
Pivot-type: 8000 gpm (1800 m<sup>3</sup>/hr)  
Plug-type: 30 ft/sec (9 m/sec)  
Side-mounted  
pivot-type: 8000 gpm (1800 m<sup>3</sup>/hr)

Maximum withdrawal rates  
Pivot-type: 17000 gpm (3850 m<sup>3</sup>/hr)  
Plug-type: 48000 gpm (10900 m<sup>3</sup>/hr)  
Side-mounted  
pivot-type: 10000 gpm (2250 m<sup>3</sup>/hr)

# ANDERSON GREENWOOD LIQUID STORAGE INTERNAL TANK VALVES

## PRODUCT OVERVIEW

NFPA No. 59A sets out the National Fire Protection Association requirements for the design, engineering and handling of liquefied natural gas. It states that when a storage tank has a bottom penetration, the least amount of surrounding property is required if an internal shutoff valve is used.

The ITV is designed to satisfy all of the Code's requirements, specifically paragraph 6333: "The design and installation of an internal valve shall be such that any failure of the penetrating nozzle resulting from external pipe strain will be beyond the shutoff seats of the internal valve itself."

The use of the ITV increases safety, minimizes property requirements and should lower insurance liability. It is designed for long trouble-free life. Design features are simple yet rugged to withstand the rigors of construction and maintenance-free. When mounted on

the tank bottom, this valve allows near 100% withdrawal of liquid. It does not depend on counter-weights or actuator forces for closing and its fail-safe condition is closed.

Both design options allow perfect seating: the pivot-type ITV disc is free to pivot within the actuating arm and therefore sits freely on its circular PTFE seal; the plug-type ITV maintains a constant geometric relation between its spherical disc face and conical seal. Seal ruggedness and long life are more important factors than absolute leak tightness and the seal may be installed as a separate unit.

A block valve is always to be provided in series with this valve. The downstream block valve must be closed before the ITV can be opened, preventing opening on an open or ruptured downstream line.

A pressure-equalizing pilot valve is integral with the valve disc and opened by the first motion of the open operator. Product flows through the pilot valve and fills the pipe to the downstream block valve, equalizing the static differential pressure across the ITV disc. The force limited operator will stop until pressures equalize at which point the opening operator will continue.

The orifice plate material is of the same type as the tank bottom and is usually supplied by the customer.

## TYPICAL INSTALLATION OF INTERNAL TANK VALVE, CABLES AND OPERATORS

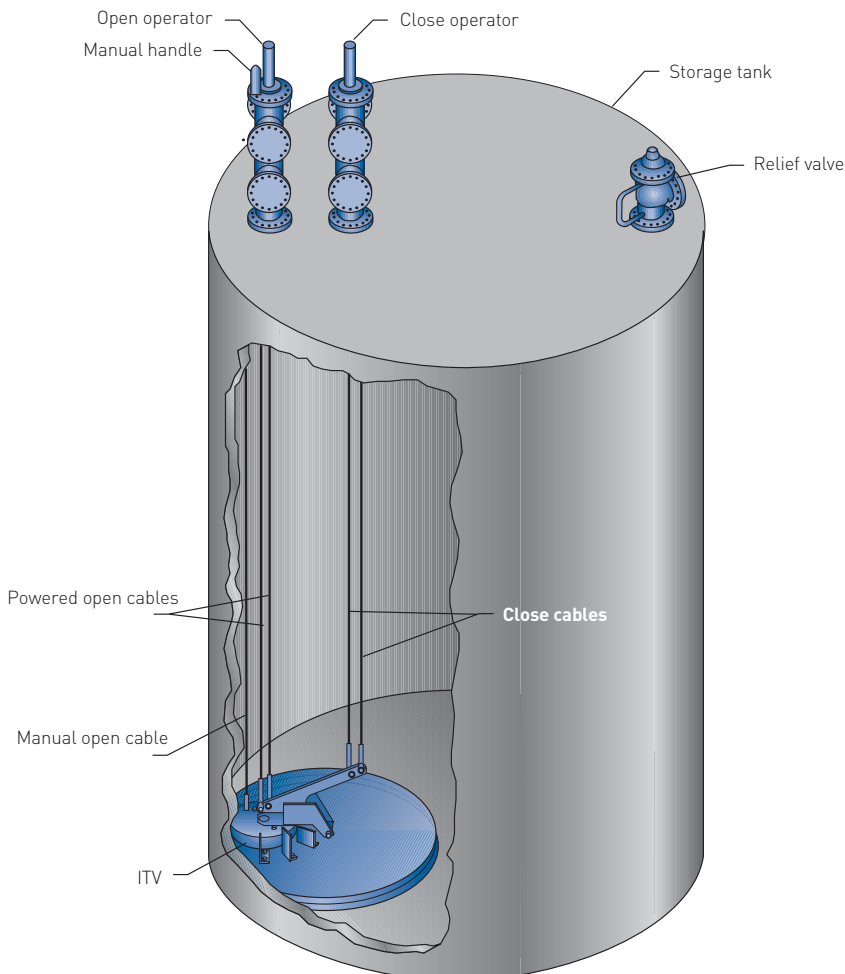

# ANDERSON GREENWOOD LIQUID STORAGE INTERNAL TANK VALVES

## PIVOT-TYPE

Developed primarily for LNG peak shaving facilities, the pivot-mounted check valve design is available in sizes 4", 6", 8", 10", 12", 14", 16" and 18" (100, 150, 200, 250, 300, 350, 400 and 450 mm). It may be used for any application where fill rates do not exceed 8000 gpm (1800 m<sup>3</sup>/hr). Maximum withdraw rates vary with size up to 17000 gpm (3850 m<sup>3</sup>/hr).

## STANDARD MATERIALS

Item	Part name	Materials
1	Orifice plate	Customer specified
2	Disc	A240-304 SS
3	Seal	TFE PTFE
4	Seal retainer	A240-304 SS
5	Lever	A240-304 SS
6	Arm	A240-347 SS
7	Cables	302/304 SS MIL-DTL-83420
8	Pivot bearing	PTFE coated 300 series SS
9	Pilot valve spring	Inconel® 600 AMS 5687
	All other parts	300 series SS (primarily 304)

## NOTE

1. Inconel® is a registered trademark of International Nickel Company

PIVOT TYPE INTERNAL TANK VALVE

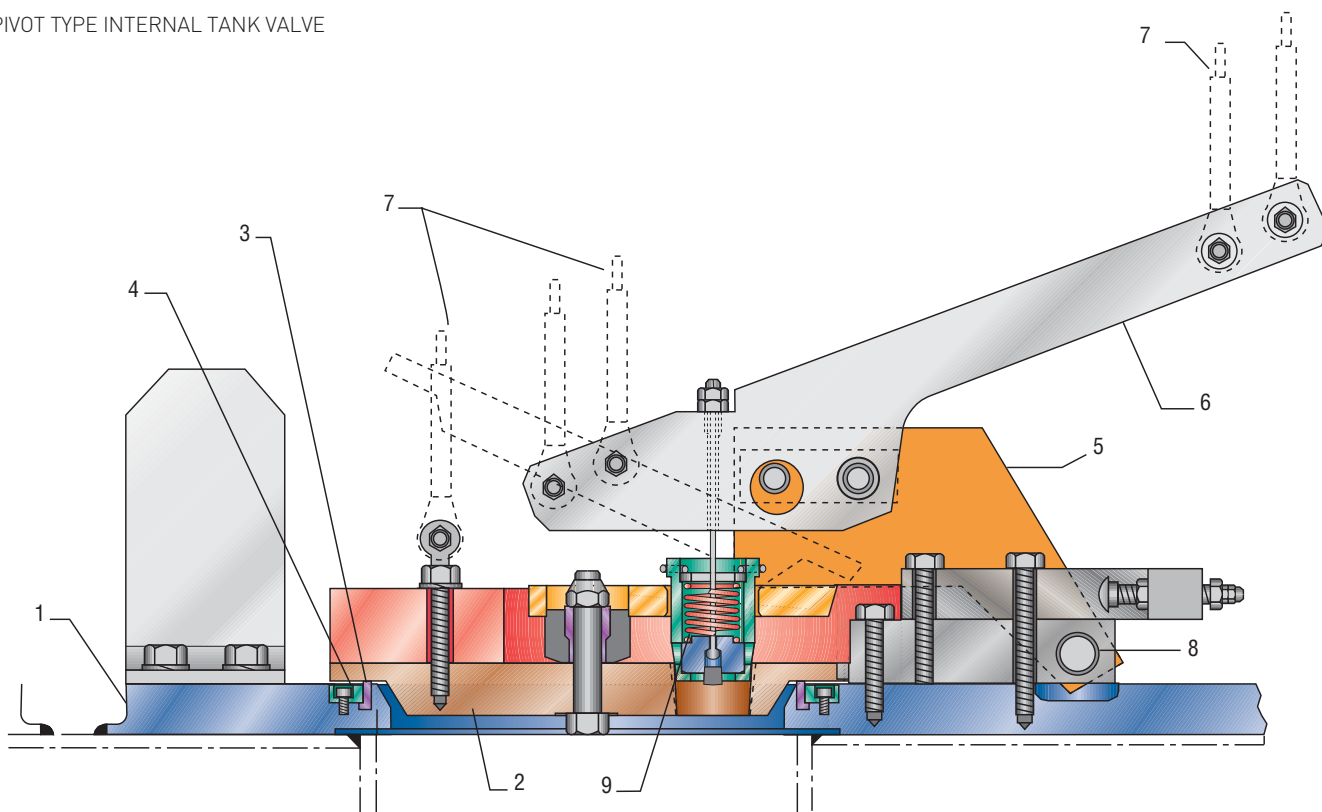

**PIVOT TYPE INTERNAL TANK VALVES**

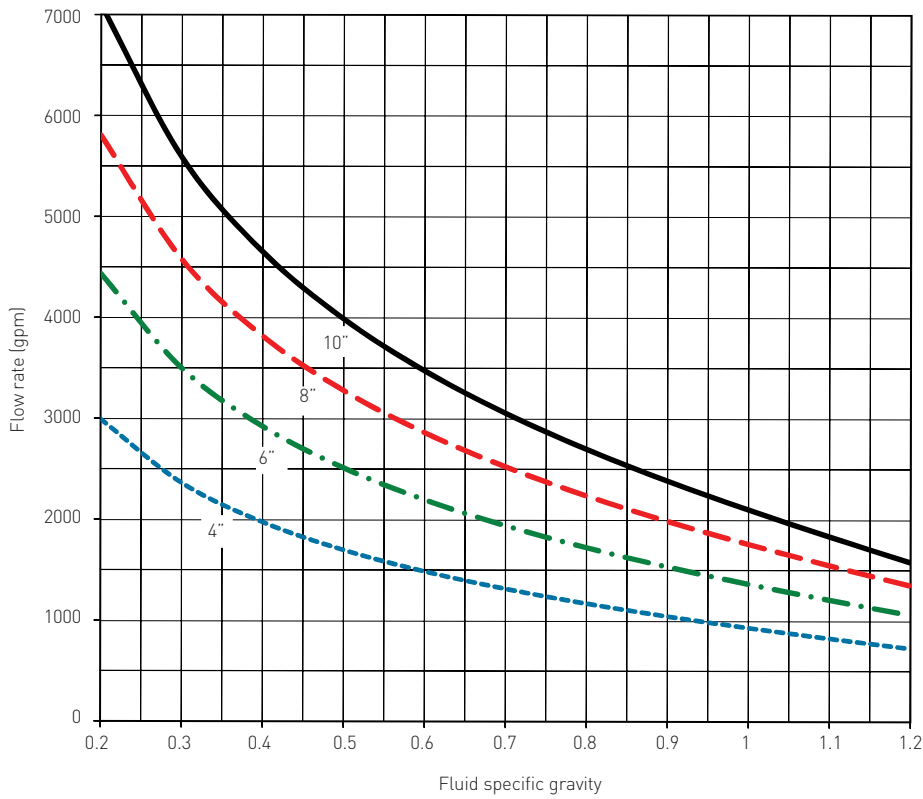

FIGURE 1  
4" to 10" pivot type ITV maximum allowable fill rates

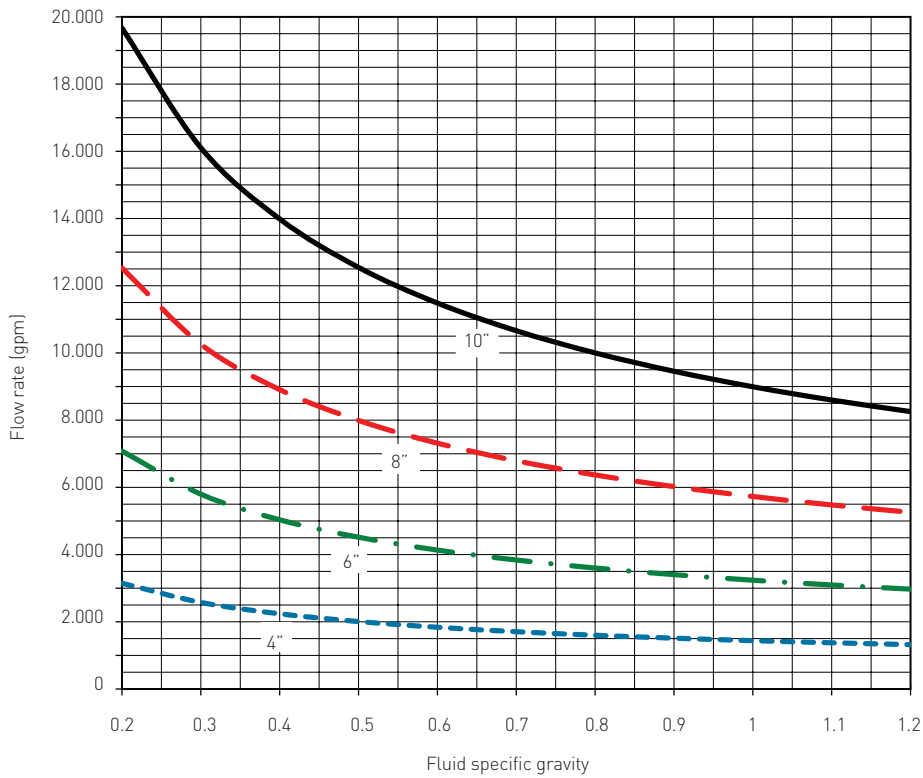

FIGURE 2  
4" to 10" pivot type ITV maximum allowable withdrawal rates

**PIVOT TYPE INTERNAL TANK VALVES**

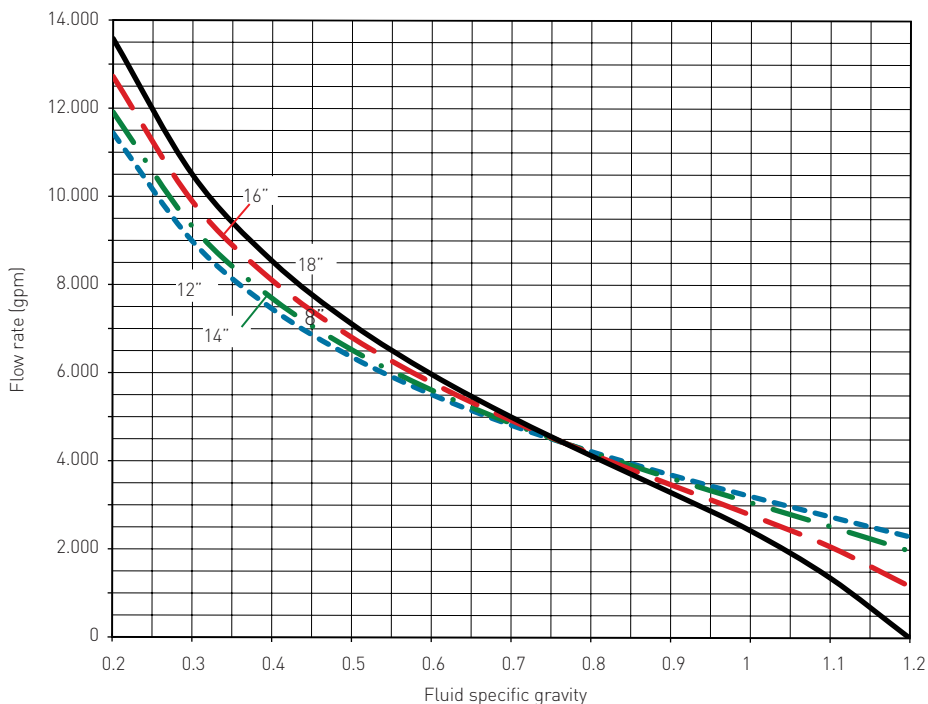

FIGURE 3  
12" to 18" pivot type ITV maximum allowable fill rates

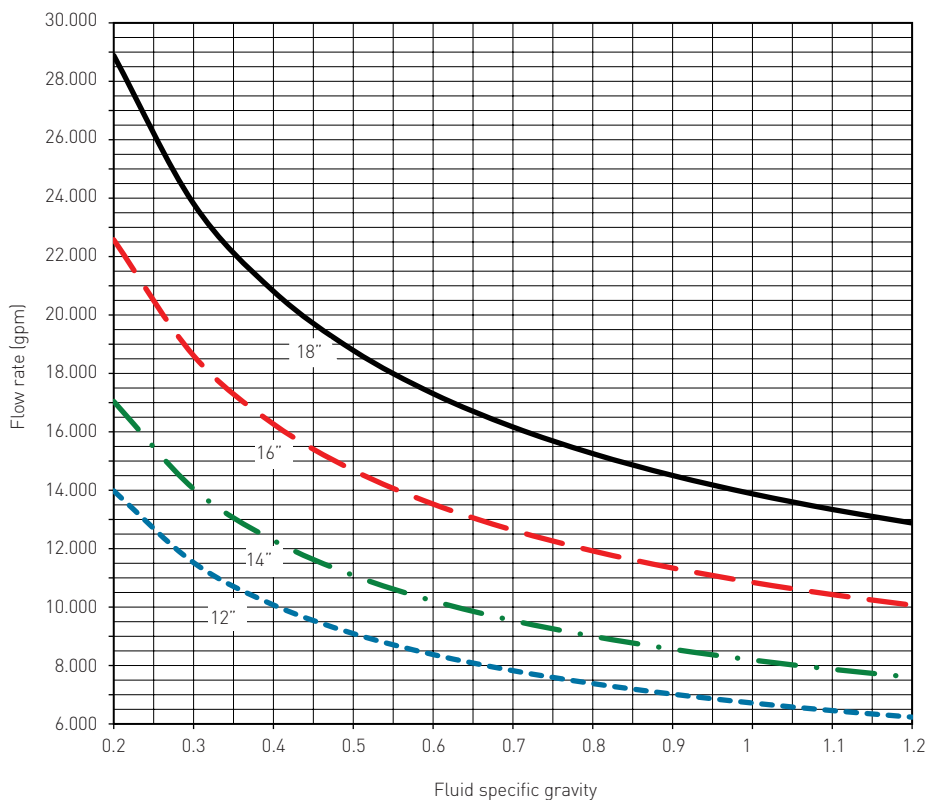

FIGURE 4  
12" to 18" pivot type ITV maximum allowable withdrawal rates

# ANDERSON GREENWOOD LIQUID STORAGE INTERNAL TANK VALVES

## PLUG-TYPE

The plug valve design in 24" and 30" (600 and 750 mm) sizes is suitable for base load liquefaction facilities and import/receiving terminals that require high inflow velocities. These valves are designed for normal inflow velocities of 30 feet per second (9 m/sec) and will accommodate 'slugging' velocities to 50 ft/sec (15 m/sec) without producing a force on the tank bottom. Stream dynamic forces on the disc are completely reacted by the weight of the disc plus the weight of the fixed valve parts. Product may be withdrawn through this valve at 48000 gpm (10900 m<sup>3</sup>/hr) maximum.

This design is also available in 6" and 12" (150 and 300 mm) sizes for LOX, LIN and other smaller scale liquefaction and storage facilities. The 6" (150 mm) model is also available in a gravity close version, eliminating close operators for an even more economical solution.

## STANDARD MATERIALS

Item	Part name	Materials
1	Orifice plate	Customer specified
2	Disc	A182-F304 SS
3	Seal	TFE PTFE
4	Seal retainer	A240-304 SS
5	Shaft	A479-304 SS
6	Straight line mech.	300 series SS (primarily 304)
7	Cables	302/304 SS MIL-DTL-83420
8	Pilot valve spring	Inconel® 600 AMS 5687
	All other parts	300 series SS (primarily 304)

## NOTE

1. Inconel® is a registered trademark of International Nickel Company

PLUG TYPE INTERNAL TANK VALVE

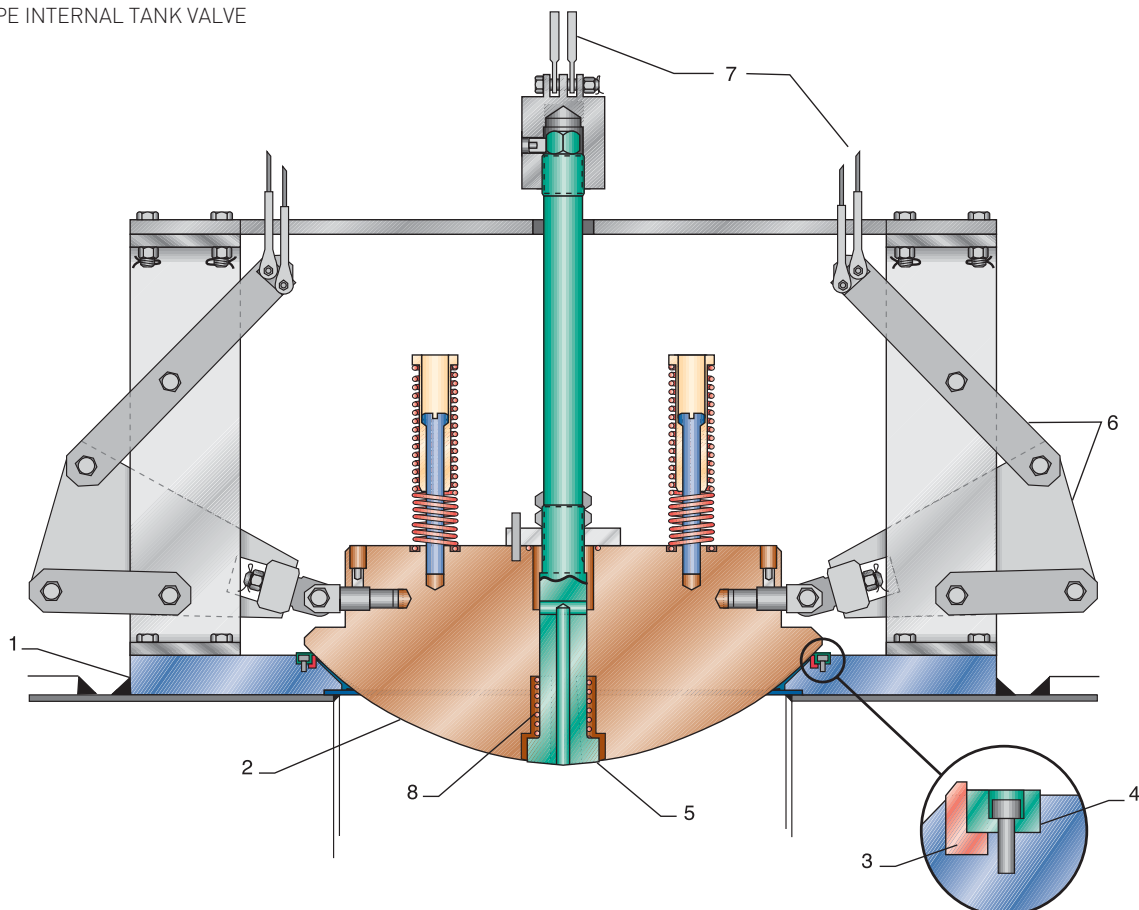

# ANDERSON GREENWOOD LIQUID STORAGE INTERNAL TANK VALVES

## SIDE MOUNTED PIVOT-TYPE

Developed for side withdrawal double-walled tanks, the side mounted pivot check valve design is available in 12", 14", 16" and 18" [300, 350, 400 and 450 mm] sizes. It may be used for any application where fill rates do not exceed 8000 gpm (1800 m<sup>3</sup>/hr). Maximum withdraw rates vary with size up to 10000 gallons per minute (2250 m<sup>3</sup>/hr).

### STANDARD MATERIALS

Item	Part name	Materials
1	Orifice plate	Customer specified
2	Disc	A240-304 SS
3	Seal	TFE PTFE
4	Seal retainer	A240-304 SS
5	Lever	A240-304 SS
6	Arm	A240-347 SS
7	Cables	302/304 SS MIL-DTL-83420
8	Pivot bearing	PTFE coated 300 series SS
9	Pilot valve spring	Inconel <sup>®</sup> 600 AMS 5687
10	Flange (150#)	Customer supplied
	All other parts	300 series SS (primarily 304)

### NOTE

1. Inconel<sup>®</sup> is a registered trademark of International Nickel Company

### SIDE MOUNTED PIVOT TYPE INTERNAL TANK VALVE

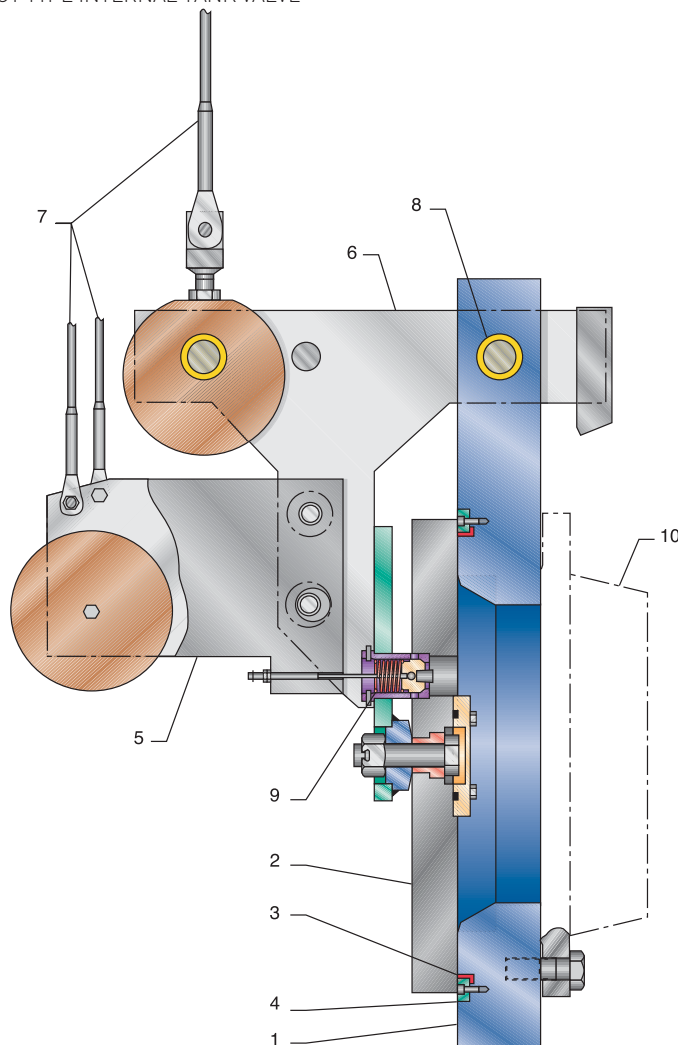

# ANDERSON GREENWOOD LIQUID STORAGE INTERNAL TANK VALVES

## OPERATORS

Operation of the ITV is by two force limited operators mounted on the tank roof: one for opening and one for closing the valve. As a backup to the primary open operator, a completely independent manual cable is provided in the 4" to 18" (100 to 450 mm) ITVs. On the 6" and 12" (150 and 300 mm) plug designs, a manual close operator is provided to allow all operating functions to be enclosed in a single housing for easier installation. For the much heavier larger models, a separate operator housing with hand operated hydraulic pump is provided for emergency use.

Stainless steel cables from the operators to the valves are installed with enough cable slack to accommodate maximum thermal and load changes of the tank top to bottom dimension. As proper cable length is critical to the valve operation, adjustment is provided inside each operator housing.

Air or hydraulic cylinders provide the necessary force to open or close the valve with a maximum required supply pressure of 100 psig (6.9 barg). The air cylinders are sized so that the system is inherently safe from overloading the bottom of the tank at operating pressures. Series 80 relief valves on the supply line provide backup assurance. Limit switches are available to indicate open and close positions.

**Schematic 'A'** shows the typical controls required for operating the ITV for withdrawal applications with limited filling velocities. Control components are normally provided by the customer but standard control packages can be provided. Regulated pressure is required for each operator. A three-way solenoid valve provides remote actuation capability. Emergency operation after loss of air supply is provided by a reserve air bottle.

## SCHEMATIC A

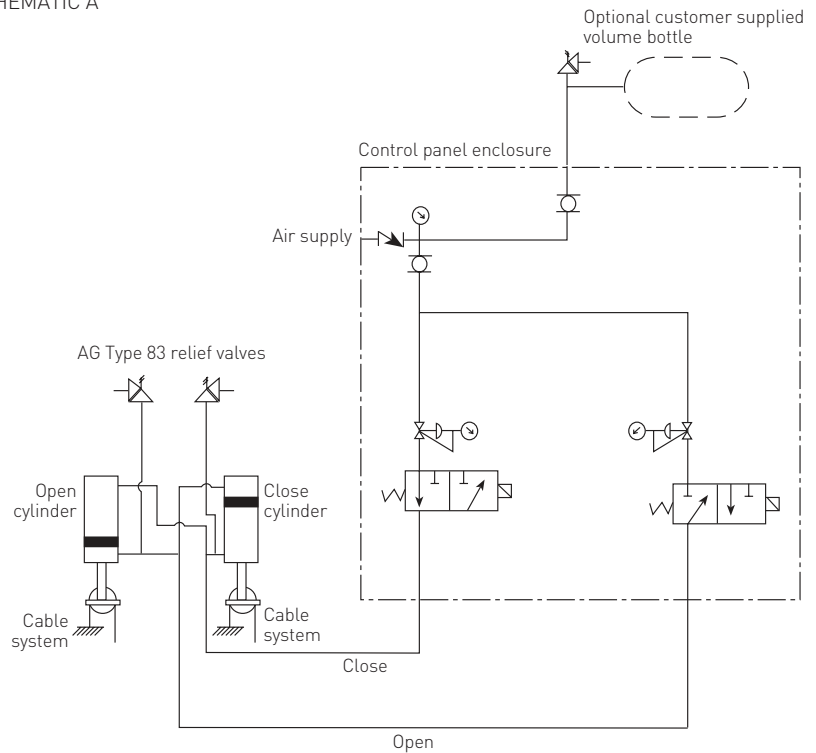



# ANDERSON GREENWOOD LIQUID STORAGE INTERNAL TANK VALVES

SCHEMATIC B

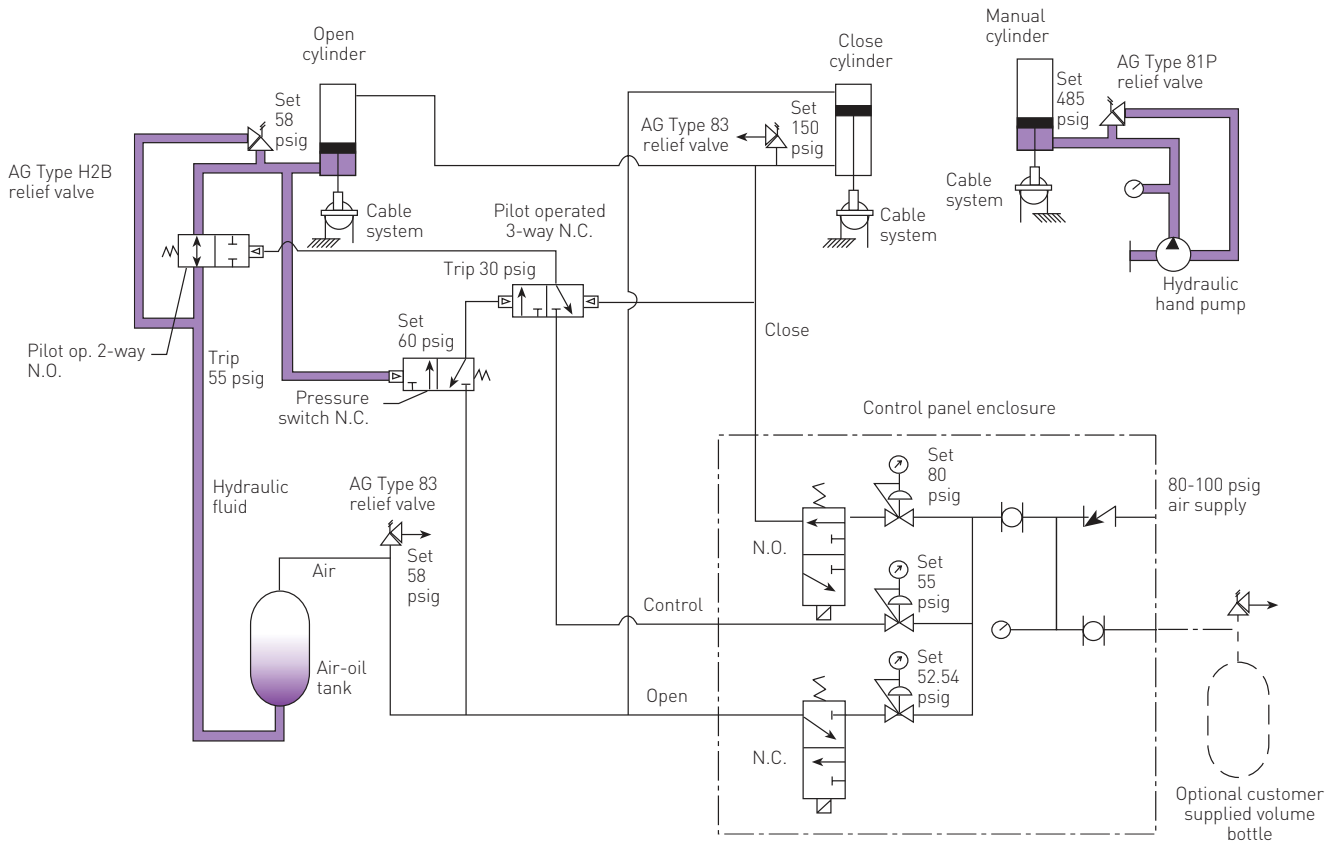

## OPERATORS

For high velocity (30 ft/sec (9 m/sec) normal) fill applications with the 24" or 30" ITV, (600 or 750 mm), **schematic 'B'** shows an air oil system that fully opens the valve disc and then suspends it so that the full disc weight is available to react against inflow dynamic forces. Control components furnished by the customer are similar to 'Schematic A'.