

AT-210/250 Diaphragm Meter



The AT-210 and AT-250 meters have a 5 PSIG Maximum Allowable Operating Pressure and can flow either 210 or 250 cubic feet per hour at 1/2" W.C. differential pressure.

Features

- Die-cast aluminum case
- Oil-impregnated, self-lubricating bushings
- Molded, convoluted diaphragms for smooth operation and long life
- Rigid, reinforced flag rods for positive alignment and sustained accuracy
- Graphite-filled phenolic valves to minimize wear
- Long-life, low friction, grommet seals
- Single coat polyester primer with high solids polyurethane top coat
- Security seals that indicate tampering

Advantages

- Temperature compensation available from -30°F to 140°F (-34°C to 60°C)
- Either 210 CFH (6m³/h) or 250 CFH (7.1 m³/h) (0.60 specific gravity gas) at 1/2-inch W.C. differential
- AMR/AMI compatibility
- Meets ANSI B109.1 specifications
- Measurement Canada accredited

Applications

The AT-210 and AT-250 were designed as replacements for the finned steelcase meters or other meters that have wide center-to-center top connections. The AT-210 has 5LT connections while the AT-250 has 10LT connections.

Options

- Regular or Temperature Compensated
- Pointer or odometer index
- 1ft³ or 2ft³ drive
- Connection Sizes
 - AT-210
 - 5LT - 11 1/4"
 - AT-250
 - 10LT - 11 1/4" or 13 3/8"
- Pressure compensating indexes
- Standard or UV protected index covers
- Remote Volume Pulsers



AT-210/250 Diaphragm Meter

Weight = 12 lbs

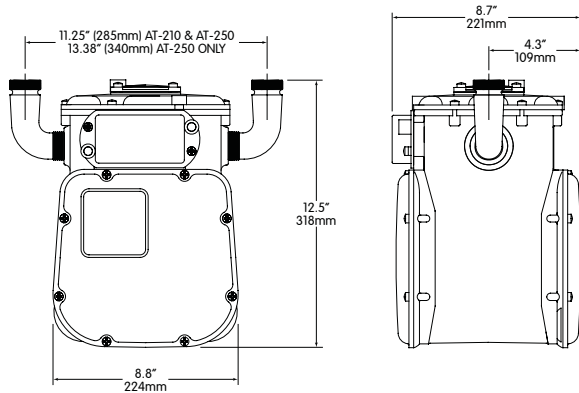

Capacities (0.60 specific gravity gas)

Line Pressure PSIG (mbar)	Differential Inches W.C. (mbar)	AT 210 SCFH (m ³ /h)	AT 250 SCFH (m ³ /h)
0.25 (17)	1/2 (1.2)	210 ^{1,2} (5.9)	250 ^{3,4} (7.1)
1 (69)	2 (5)	410 (11.6)	528 (14.9)
2 (138)	2 (5)	424 (12.0)	550 (15.6)
5 (345)	2 (5)	462 (13.1)	595 (16.8)

1 - Propane - 132 SCFH (3.7 m³/h) 3 - Propane - 158 SCFH (4.5 m³/h)
 2 - Butane - 116 SCFH (3.3 m³/h) 4 - Butane - 138 SCFH (3.9 m³/h)

AT-210/250 Proof Curve

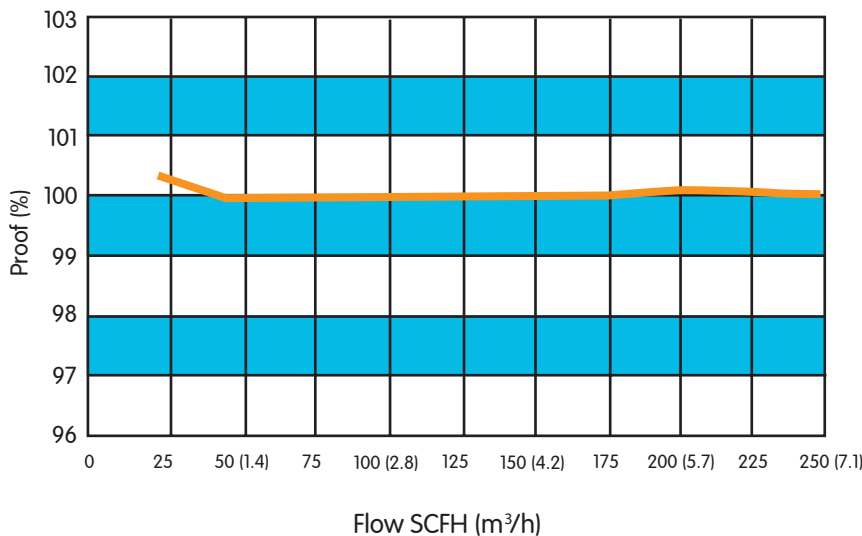

About Elster Group

A world leader in advanced metering infrastructure, integrated metering, and utilization solutions to the gas, electricity and water industries. Elster's metering and system solutions reflect over 170 years of knowledge and experience in measuring precious resources and energy.

Elster provides solutions and advanced technologies to help utilities more easily, efficiently and reliably obtain and use advanced metering intelligence to improve customer service, enhance operational efficiency, and increase revenues. Elster's AMI solutions enable utilities to cost-effectively generate, deliver, manage, and conserve the life-essential resources of gas, electricity, and water.

Elster has a staff of over 7,500 serving customers globally in North America, Central America, South America, Europe, Asia, Africa and the Middle East.

ISO 9001:2000



Certification No. 006697