

J48K & KC

Pressure Relief &
Creep Relief Valves
Nominal Diameter 1" & 2"



Applications

- Industrial
- Commercial

Brief information

Operation: As part of the comprehensive range of safety equipment, Elster Jeavons produces two special versions of the proven J48 range. These are the J48K pressure relief valve and the J48KC creep relief valve. Both versions incorporate new quick release spring adjustment mechanisms which provide easy access for spring adjustment and routine maintenance.

Application J48K: The J48K pressure relief valve guards against excess pressure. The valve is fully automatic in operation and resets when the pressure falls below the pre-set value.

Application J48KC: The J48KC creep relief valve is normally fitted on a skid or modular units. It prevents the build up of pressure on the downstream side during periods of zero demand in the event of main stream valves not locking up. The units are sized so that their maximum capacity is less than 1% of the full fault capacity of the skid or modular unit (British Gas Specification BGC/PS/E26).

Both versions, which are designed for natural, liquid petroleum and manufactured gases, can be installed in horizontal and vertical pipelines.

Control: A comprehensive range of springs is available. The relief pressure can be easily and accurately adjusted by turning the spring adjustment unit located under the top cap. The design of this mechanism provides virtually frictionless adjustment and eliminates "spring wind up".

The complete spring adjustment mechanism can be removed easily for maintenance and spring changes. If required the units can be supplied factory set with a security seal at extra cost.

Technical Data: Maximum Relief Pressure: 150mb (60"wg)

Servicing: The J48K and KC have been designed for ease of access, inspection and servicing of all internal components. A standard soft spares kit is available for all sizes.

1" reference number SK4806-01
2" reference number SK4809-01.

Main features

- Sizes: J48K - 1" and 2"
- Sizes: J48KC - 1"
- Temperature range -20°C to +70°C
- Threaded connections to BS EN 10226 (ISO 7) or NPT (other threads may be available upon request)
- Spring loaded
- Quick release spring adjustment
- Can be mounted in any orientation (may need to be re-set after installation).



CONTROLS SUPPLY CHAIN
VALVES ACTUATORS INSTRUMENTATIONS

www.controlssupplychain.com | info@controlssupplychain.com

J48K: Pressure Relief Valve

Relief Capacities

RELIEF VALVE SIZE: 1"

RANGE (mbar)	SPRING No.	SETTING (mbar)	PRESSURE BUILD UP ABOVE RELIEF SETTING (mbar)							
			2.5	5.0	7.5	12.5	17.5	35	53	70
12 – 24	J4808-004 Red / Yellow	12.5	20	34	42	51	58	73	80	92
		18.5	20	35	43	58	60	73	81	96
		23.5	21	35	48	64	66	78	87	97
22 – 37	J4806K-011 Red / Silver	22.5	16	23	46	58	64	76	84	97
		30.0	18	28	47	61	68	81	89	101
		37.5	19	35	48	64	73	87	94	104
37 – 62	J4808-007 Red / Black	37.5	9	18	32	57	71	85	94	104
		50.0	21	29	42	58	76	94	101	111
		62.5	23	32	46	71	81	99	108	117
62 – 102	J4809-004 Blue / Black	62.5	11	16	32	48	67	99	106	117
		83.0	14	19	35	58	74	108	117	124
		103	16	32	44	62	87	119	126	135
102 - 150	J4809-005 Blue / Orange	103	11	16	30	58	81	117	126	135
		126	16	21	27	53	81	124	135	143
		150	18	25	35	53	79	121	131	138

RELIEF VALVE SIZE: 2"

RANGE (mbar)	SPRING No.	SETTING (mbar)	PRESSURE BUILD UP ABOVE RELIEF SETTING (mbar)							
			2.5	5.0	7.5	12.5	17.5	35	53	70
12 – 24	J4809K-006 Silver / Yellow	12.5	25	71	126	195	216	278	320	407
		18.5	35	88	145	216	241	304	329	402
		23.5	35	94	150	227	262	317	389	416
22 – 37	J4809K-007 Silver / Black	22.5	13	64	127	212	216	311	353	411
		30.0	21	69	149	242	276	334	372	430
		37.5	27	93	170	252	300	350	393	451
37 – 62	J4809K-008 Silver / Gold	37.5	27	66	133	221	265	345	385	434
		50.0	30	90	142	285	323	389	420	469
		62.5	40	97	177	323	350	411	429	487
62 - 150	J4809K-005 Silver / Green	62.5	5	18	35	53	88	274	363	487
		83.0	7	21	39	60	96	285	407	510
		103	9	21	42	64	99	308	450	545
		126	14	28	46	67	99	322	467	570
		150	16	35	53	71	110	329	485	577

J48K: Pressure Relief Valve Relief Capacities

The relief valve will begin to open and relieve when the inlet pressure rises to the setting pressure. In the tables above the inlet pressure is increased above the listed setting pressure and the resultant relief flow is recorded.

The capacities on the previous pages are given in SCMH of natural gas (0.64 SG). For other gases multiply the capacity by:

$$\sqrt{\frac{0.64}{\text{gas sg}}}$$

GAS	SG
Air	1.00
Towns Gas	0.50
Propane	1.53
Propane / Air	1.20

J48K & KC: Pressure Relief Valve

Dimensions and Weights

SIZE	A	B	C	D	E	Weight (Kg)
1"	134	125	34	132	166	1.0
2"	234	200	52	167	219	3.1

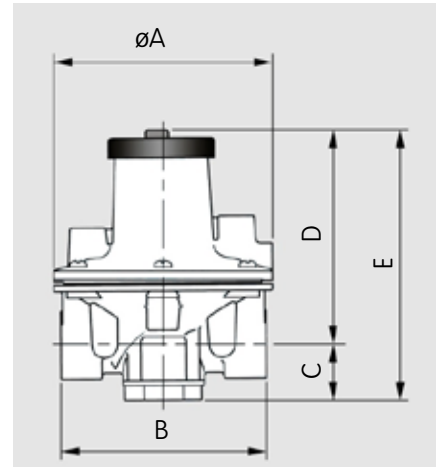

Material Specifications

A summary of the material specification for the J48K is given for reference. All material has been selected to provide maximum durability and reliability in service.

Components	Specification
Body, cover, spring adjusting bush, spring adjusting screw and bottom plug, valve spacer, valve disc clamping washer, valve spindle guide.	Aluminium Alloy
Top cap, locking lever, spring holder, diaphragm spacer.	Acetal Resin (Top cap and locking lever UV stabilised)
Diaphragm plate.	Mild steel
Main diaphragm, secondary diaphragm, valve disc and "O" rings.	Nitrile (Buna)
Springs	Carbon Steel
Impulse tube	Brass

Quality:

Elster Jeavons is committed to a programme of continuous quality enhancement. All equipment designed and manufactured by the Elster-Instromet group benefits from the group's quality assurance standards which are approved to EN ISO9001:2008.

Loading Springs

All springs are colour coded for ease of identification.

Spring Range		1"	2"
mbar	"wg		
12 – 24	5 – 10	J4808-004 Red / Yellow	J4809K-006 Silver / Yellow
22 – 37	9 – 15	J4806K-011 Red / Silver	J4809K-007 Silver / Black
37 – 62	15 – 25	J4808-007 Red / Black	J4809K-008 Silver / Gold
62 – 102	25 – 41	J4809-004 Dark Blue / Black	J4809K-005 Silver / Dark Green
102 - 150	41 - 60	J4809-005 Dark Blue / Orange	J4809K-005 Silver / Dark Green

Ordering Information: Part No. J0042, J0048